

SCALE **4WD** Series

**BOLT-ON KIT**  
PARTIAL ASSEMBLY REQUIRED

**BOOMRACING** 

# BRX01

## AWB

**ADJUSTABLE WHEELBASE 1/10 4WD RADIO CONTROL CHASSIS KIT**

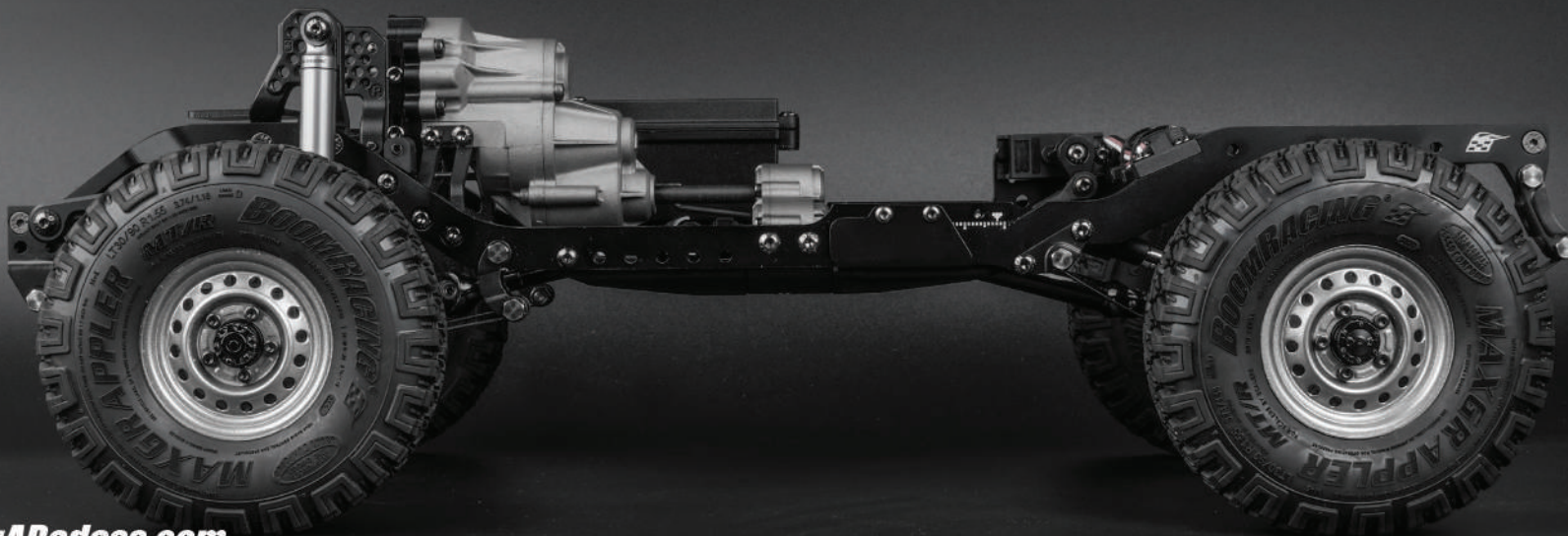

Product Codes:  
Full Kit w/ Zil Pickup Body - BR8010  
Builder's Kit - BR8011  
INSTRUCTION MANUAL  
VERSION 1.0

Photo for reference only.

# BUILT TO ADAPT, ENGINEERED TO PERFORM

## Welcome to the Boom Racing Family!

Congratulations on your new BRX01 AWB chassis! You now own a truly extraordinary platform, engineered for adaptability and high performance.

## Your Unique Vehicle Identity

Every BRX01 AWB comes with a customized chassis plate and a pair of unique license plates. The chassis plate includes your Vehicle Identification Number (VIN #) and vehicle number, which matches the license plates. Use both numbers to register your chassis and unlock exclusive benefits.

## Why Register?

By registering, you'll get access to:

- ✓ Vehicle history and details
- ✓ Factory warranty and replacement parts
- ✓ Exclusive event promotions at Boom Racing events
- ✓ Mileage tracking through Scaletra app

## How to Register?

1. Visit BoomRacing.com > Vehicle Registration
2. Log in or create an account.
3. Fill out the vehicle registration form. In the chassis detail section, select the car model BRX01 AWB, and use the vehicle number and VIN number found on the chassis plate.
4. Submit the form. If the details are correct, your vehicle will be registered immediately.

## Track Your Adventures with Scaletra

We're excited to partner with **Scaletra Adventure**, the RC tracking app for scale trail enthusiasts. Scaletra lets you log your trail runs, build your virtual RC garage, join challenges, and connect with the community, and more!

As a BRX vehicle owner, you get exclusive benefits:

- Automatically sync your registered vehicles from your Boom Racing account to Scaletra.
- Register new BRX vehicles directly on Scaletra — they'll sync back to your Boom Racing account.
- Add an unlimited number of BRX vehicles to your Scaletra garage.
- Vehicle mileage syncs back to your Boom Racing account.

Thank you for choosing Boom Racing. Now, get out there and commit some badassery!

## CHASSIS PLATE



Scan to register your BRX01 AWB

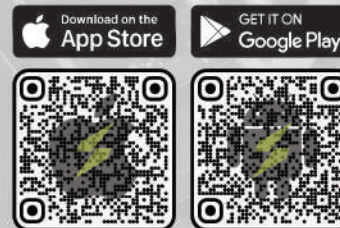

## LICENSE PLATE



FRONT AND REAR



A Bolt-On Kit means parts of the chassis are pre-assembled and require minor assembly for completion. The factory assembled parts offer convenience for builders eager to get started. The BRX01 AWB kit includes factory pre-built axles, transmission, transfer case and shocks. Shocks require oil to be filled (included).



The Scale 4WD Series is Boom Racing's line of scale based 4WD R/C products geared towards realistic appearance.



⚠ NOT RECOMMENDED FOR CHILDREN UNDER 14 ⚠

THIS CHASSIS KIT IS NOT A TOY. FIRST-TIME BUILDERS SHOULD SEEK ADVICE FROM PEOPLE HAVING BUILDING EXPERIENCE IN ORDER TO ASSEMBLE THE MODEL CORRECTLY. ASSEMBLE THIS KIT ONLY IN PLACES OUT OF CHILDREN'S REACH.



### BEFORE YOU PROCEED

Congratulations! Owning the BRX01 AWB is a truly special experience.

Carefully read and follow all instructions to prevent serious damage to your model. Failure to follow these instructions will be considered abuse and/or neglect.

Study the instructions thoroughly before assembly.

There are many small screws, nuts and similar parts. Assemble them carefully referring to the drawings. Follow the steps exactly as shown to build the vehicle correctly without issues.

If you decide to return the BRX01 AWB, do not begin assembly. Your hobby dealer will not accept a model for return or exchange after you have started assembly.

Boom Racing offers Spare Parts & Upgrade Options for improved performance. Visit our website (<https://www.enjoybeingabadass.com>) or your local Boom Racing dealer for assistance. Please note that specifications, availability and price are subject to change without notice.

### SAFETY PRECAUTIONS

All of us here at Boom Racing want you to enjoy your new vehicle. Operate your BRX01-AWB sensibly and with care, and it will be exciting, safe and fun for you and those around you. Failure to operate your BRX01 AWB in a safe and responsible manner may cause damage and injury and void your warranty.

Follow these outlined rules for safe radio control operation

- Read carefully and fully understand the instructions before assembly.
- ***This model is not intended for use by children (minors) under 14 years of age without the supervision of a responsible and knowledgeable adult who should also read the instructions.***
- When assembling this kit, extra care should be taken to avoid personal injury. Keep out of reach of small children.
- Avoid running the vehicle in crowded areas and near small children.
- BRX01 AWB can be very fast and quiet. It could cause injury to those unaware of its presence.

Inspect Your BRX01 AWB Before and After Operation

- Make sure that all screws and nuts are properly tightened.
- Use thread lock on screws for any metal on metal surface.
- Adjust steering servo and trim so that the BRX01 AWB runs straight with transmitter in neutral.
- Disconnect/remove all batteries after operation.
- Replace any batteries that have been dented, are bloated, or have frayed wires, short circuits can cause fire.
- Completely remove sand, mud, dirt etc after use to prolong the life of the BRX01 AWB.
- Maintain bearings by cleaning or replacing them regularly.

## WARRANTY

### Boom Racing's One (1) Year Factory Limited Warranty – A Peace Of Mind Right From The Start

#### WHO IS COVERED

This warranty is extended to the original end-user that registers it online (<https://www.boomracing.com/vehicleregistration>) only, whether purchased or received as a gift.

#### FACTORY LIMITED WARRANTY

#### What Is Covered and For How Long

Boom Racing warrants that all new products are free from defects in manufacturing, materials and workmanship for a period of one (1) year from date of retail purchase. The receipt or invoice at the time of purchase is your proof of purchase and is required for Boom Racing to honor any warranty.

#### What Is Not Covered

It does not cover defects or malfunction caused by user error of assembly, damages due to normal wear and tear, failure to follow operating instructions, misuse or abuse, users' failure to perform routine maintenance, or use with products with which is not intended to be used. It also does not cover damages caused by unauthorized alteration, modification or repair. It does not cover cosmetic or incidental damages. Boom Racing does not warrant or provide service or support for any third party products.

The JX mini servo warranty will be void if it is disassembled.

#### What We Will Do

We will, at our discretion, repair or replace any product free of charge that is incorrectly made or proves to be defective in material or workmanship during the warranty period. If your product is no longer being manufactured or is out of stock, we may replace your product with a comparable or improved product at our option.

#### What We Will Not Do

We will not pay for shipping, insurance or transportation charges from you to us, or any import fees, duties and taxes.

#### What To Do To Obtain Warranty Service

To obtain warranty service for products purchased from a third-party, retail or directly from Boom Racing you must return the product with proof of purchase using the following procedures:

1. Contact Boom Racing Customer Support for specific warranty instructions via our website, by email, telephone, or our social media accounts:
  - Online @: <https://www.boomracing.com/contact-us>
  - Email: [sales@boomracing.com](mailto:sales@boomracing.com)
  - Facebook Messenger: ([www.fb.com/boomracingrc](http://www.fb.com/boomracingrc)) or Instagram: DM @boom\_racing
 You may be asked to complete a warranty service request form. A copy of your purchase receipt may be required.
2. Our Customer Support may ask you to return and ship the defective product back to us. Label and ship the product, freight prepaid, to the address provided by Boom Racing; and
3. Place any necessary return authorization number prominently on the outside of the return packaging. Return packaging not bearing a return authorization number where required may be refused.

Boom Racing reserves the right to final decision, change or modify this warranty without notice.

## Equipment Required



3CH Radio

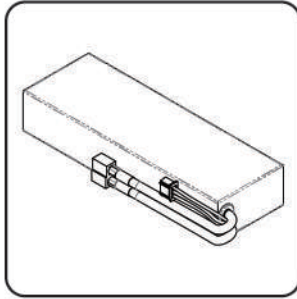

Battery

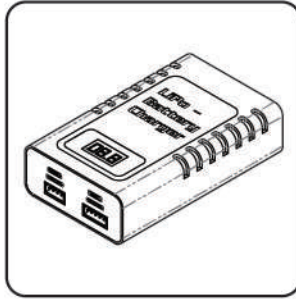

Charger

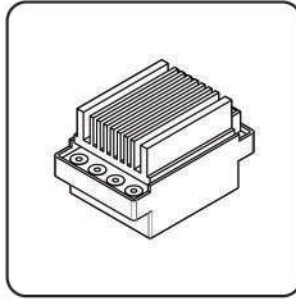

ESC

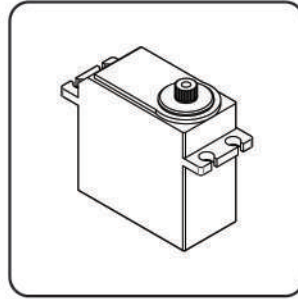

Steering Servo

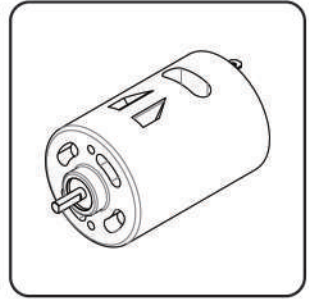

540/550 Motor

## Tools Recommended

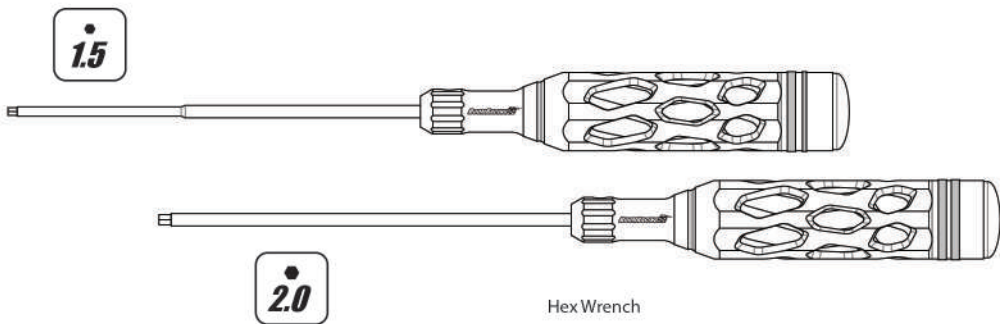

Hex Wrench

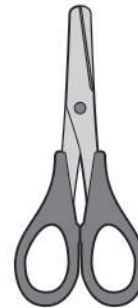

Scissors



Hobby Knife



Shock Shaft Pliers

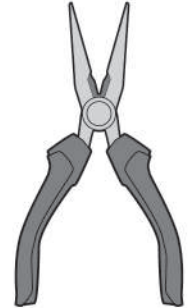

Long Nose Pliers



### Thread Lock

Apply thread lock to places shown by this mark.  
Apply thread lock first, then assemble.  
(Do Not Use Red Loctite)



### Black Graphite Grease

Lubricate all gears.  
Apply grease to the places shown by this mark.  
Apply grease first, then assemble.



### Silicone Grease

Lubricate all moving parts including joints and bearings.  
Apply grease to the places shown by this mark.  
Apply grease first, then assemble.



### Shock Oil

Apply shock oil to the places shown by this mark.



Apply Double Side Tape



Item not included.



Pay attention to note on page.

**PART LOCATION MAP (TOP)**

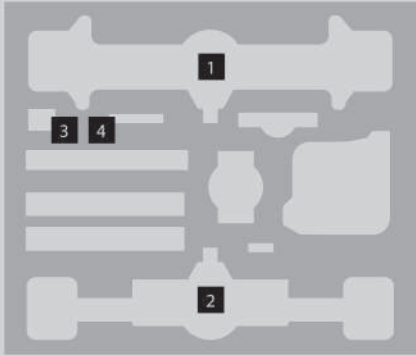

1

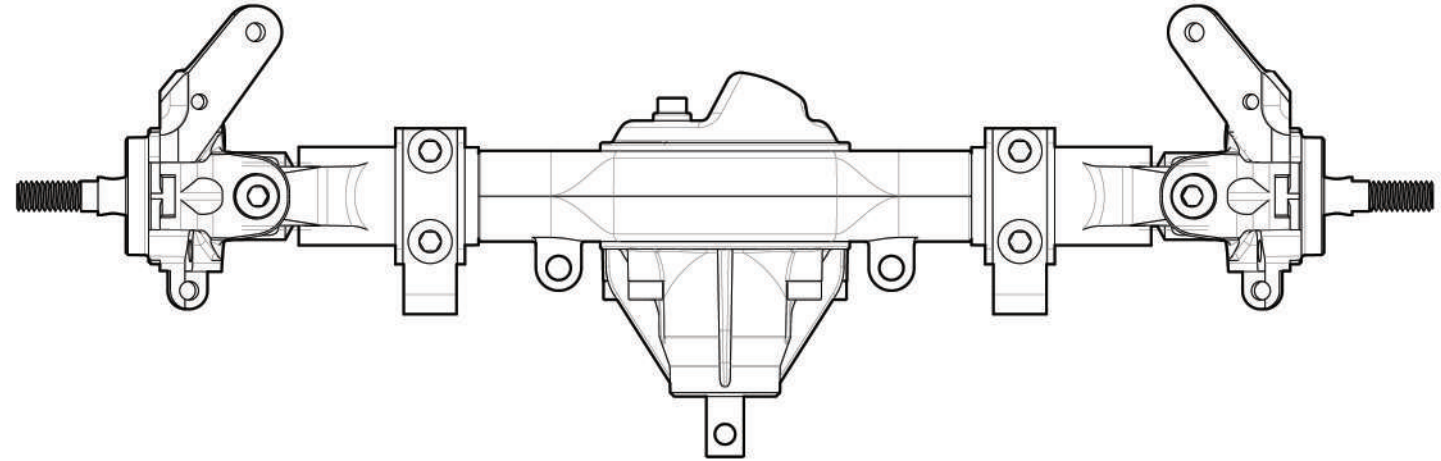

BRX80 Complete Front PHAT™ Axle Leaf Spring Ver x 1  
#BRX020115F

2

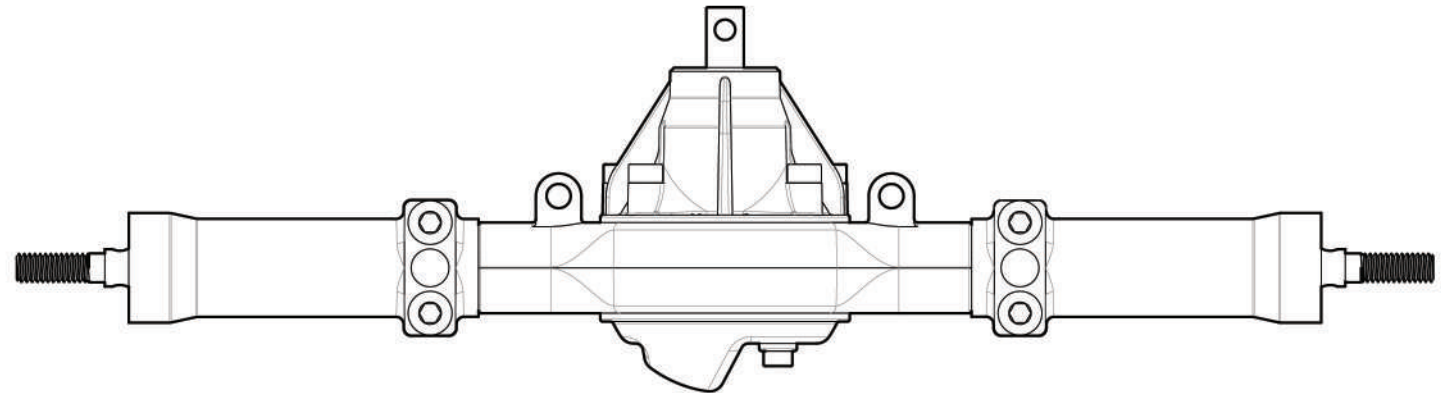

BRX80 Complete Rear PHAT™ Axle Leaf Spring Ver x 1  
#BRX020115R

3

#BRX020110

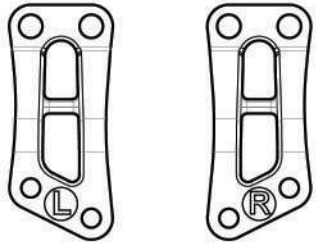

Side Gearbox Mount - Left x 1    Side Gearbox Mount - Right x 1

4

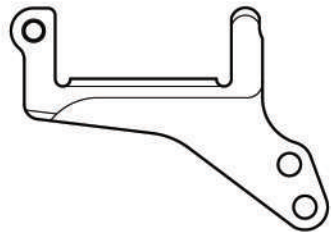

Mini Servo Mount for AWB x 1  
#BRLC70223R

**PART LOCATION MAP (TOP)**

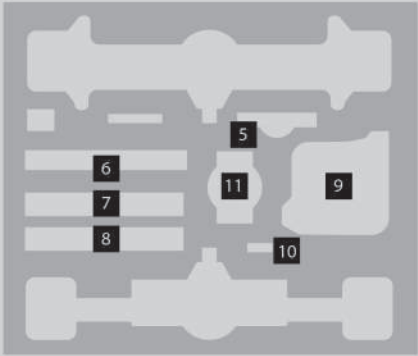

**5** #BRLC7027

Gearbox Adapter x 1      Motor Mount x 1

**6**

KUDU™ 70mm Scale Shock Absorbers x 4  
#BRSH0070

**9** #BRX020029

BCF2™ Aluminum Gearbox Housing x 1

**7**

KUDU™ Heavy-Duty 80-90mm Steel CVD Center Drive Shaft x 1  
#BRKD003-90

**8**

KUDU™ Heavy-Duty 84-99mm Steel CVD Center Drive Shaft x 1  
#BRKD003-94

**10**

Low Profile Servo Horn 25T Black x 1  
#BR955014BK

**11** #BRX020111

B2X™ Transfer Case Housing (OD Ready) x 1

**PART LOCATION MAP (TOP)**

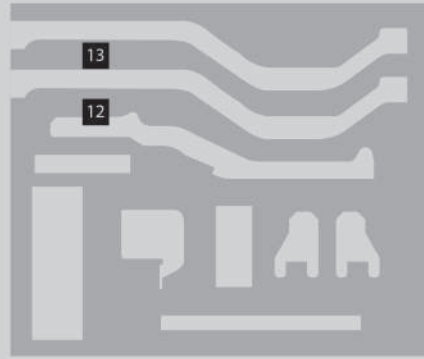

12

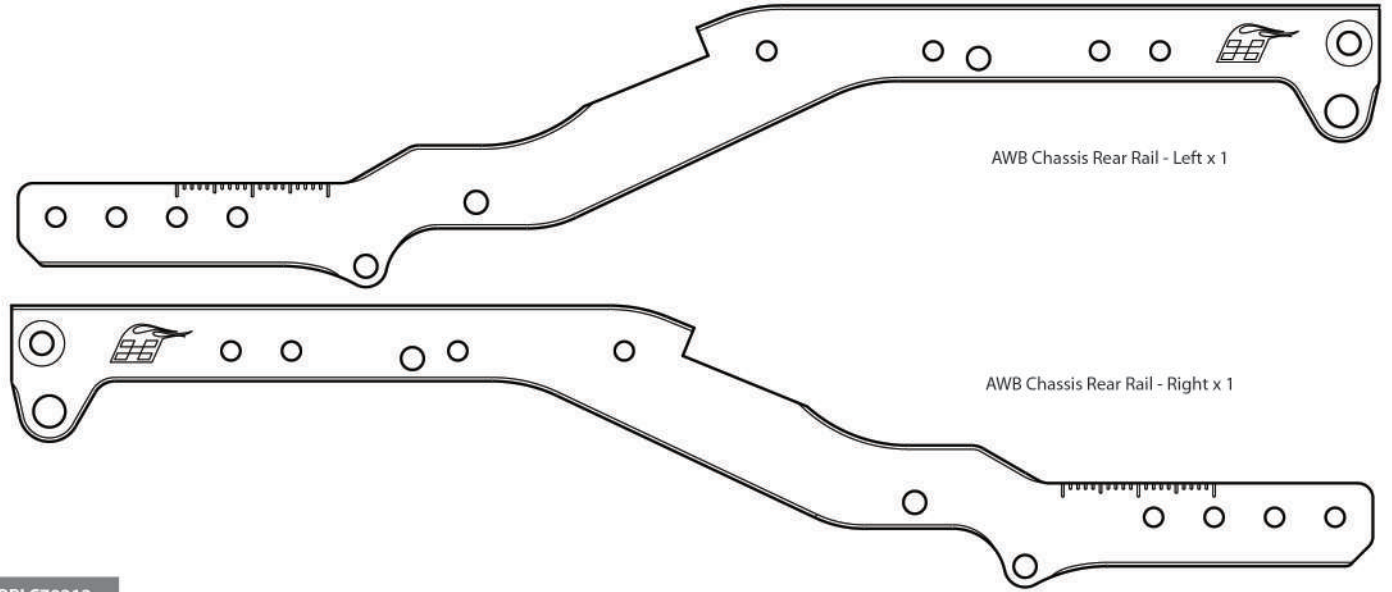

#BRLC70212

13

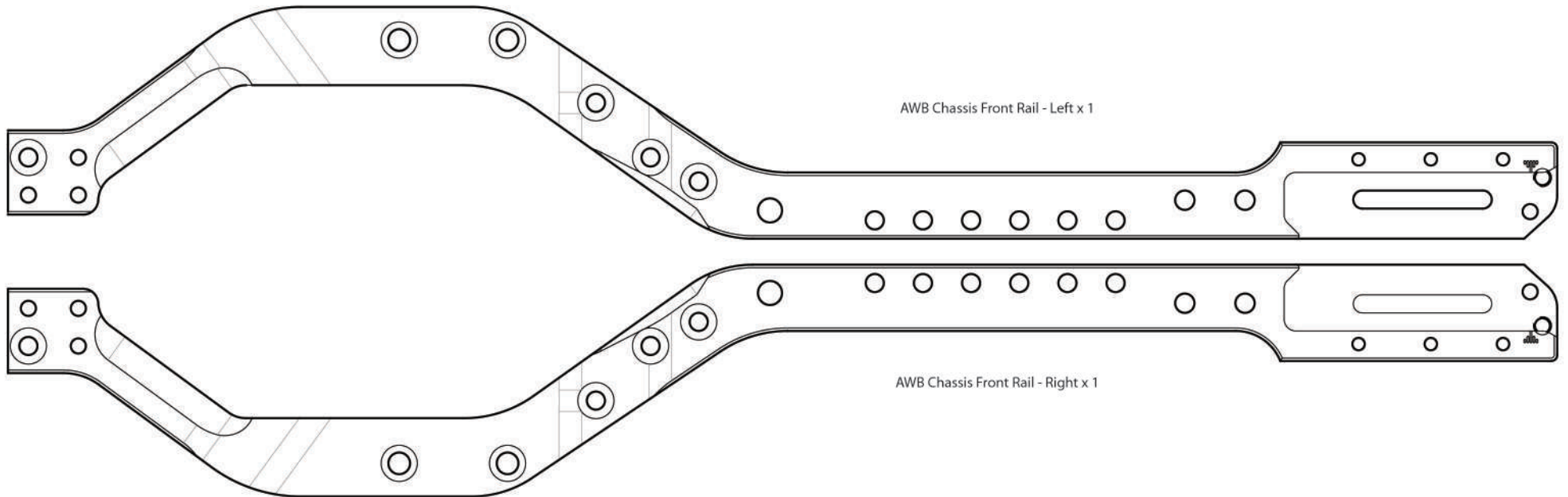

#BRLC70211

**PART LOCATION MAP (TOP)**

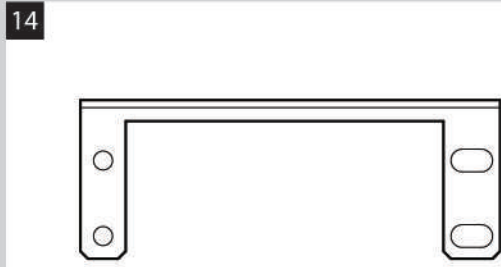
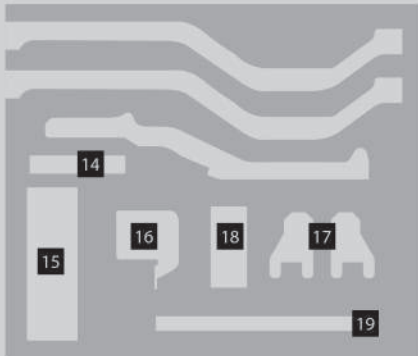

Steering Servo Mount for CMS Setup x 1  
#BRLC7016

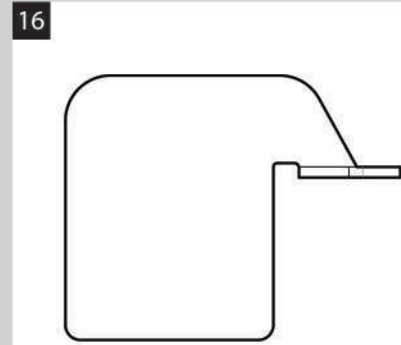

AWB ESC Plate x 1  
#BRLC70222

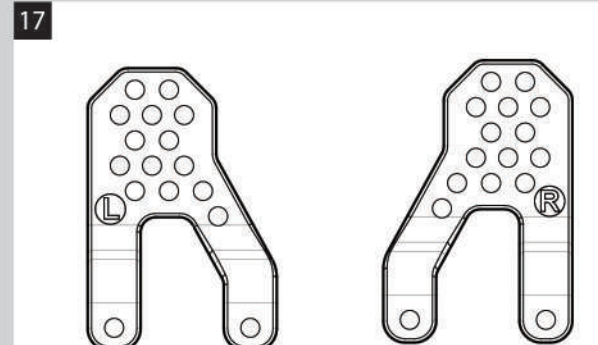

AWB Front Offset Shock Tower  
- Left x 1

AWB Front Offset Shock Tower  
- Right x 1

#BRLC70218

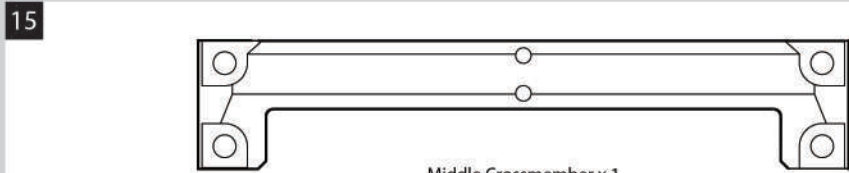

Middle Crossmember x 1  
#BRLC7014

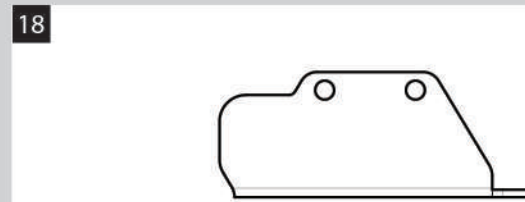

AWB Chassis Side Bracket - Left x 1

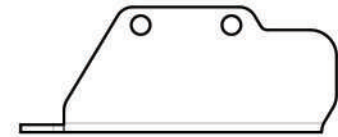

AWB Chassis Side Bracket - Right x 1

#BRLC70214

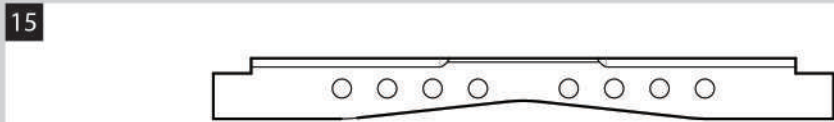

Center Crossmember for BRLC7064 Leaf Spring x 1  
#BRLC7064B



AWB Switch Lever  
#BRLC70207

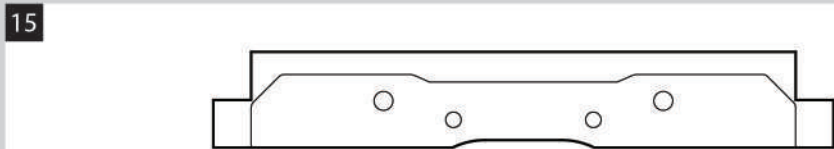

AWB Front Crossmember x 1  
#BRLC70202

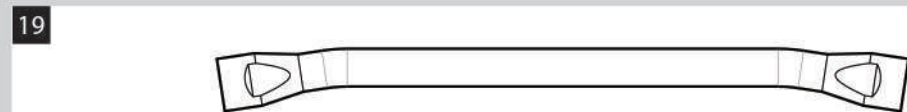

Stainless Steel Tie Rod (1) for BRX80 PHAT™ Axle x 1  
#BRD8022A

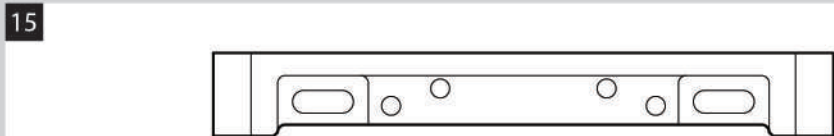

AWB Rear Crossmember x 1  
#BRLC70206

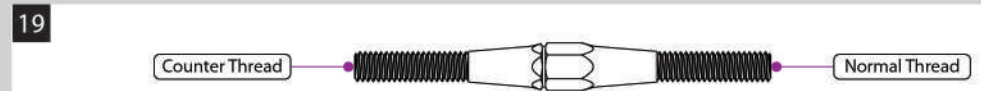

Stainless Steel Drag Link - 55mm x 1  
#BRLC7050



AWB Front Anti-Wrap Bar x 2  
#BRLC70208



AWB Slotted Plate x 2  
#BRLC70215



AWB Slotted Washer x 4  
#BRLC70216



Brass Washer x 4  
#BRX020030

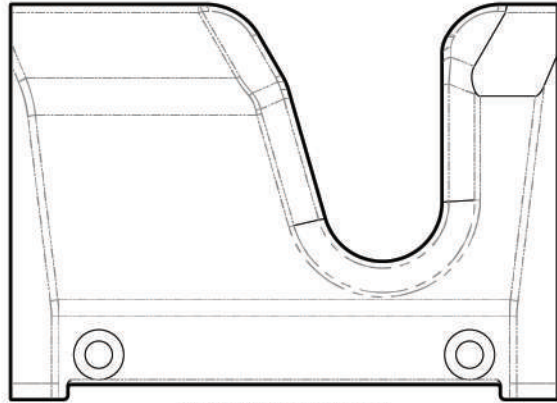

AWB Center Front Slider x 1  
#BRLC70220F

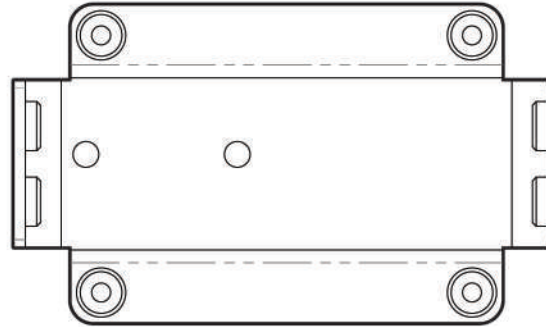

Center Skid Plate x 1  
#BRX020020LF

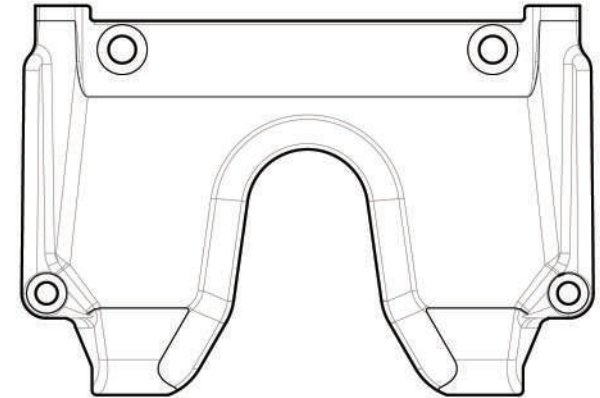

AWB Center Rear Slider x 1  
#BRLC70220R

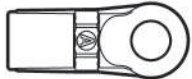

KUDU™ M4 Nylon Rod End  
(Straight 18.5mm) x 6  
#BRW750306A

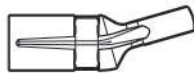

KUDU™ M4 Nylon Rod End (D)  
(Upwards 20mm) x 2  
#BRW750307D



BADASS™  
Stainless Steel Pivot Ball x 8  
#BRW750300



M2 Link Rod End Ball Joint x 1  
#BRQ90351

**B LEAFS / SHOCKS**



M3x12 RS x 2 #BRASBH3012  
M3x16 RS x 4 #BRASBH3016  
M3x20 RS x 2 #BRASBH3020  
M3x22 RS x 3 #BRASBH3022



M3x24 RS x 2 #BRASBH3024  
M4x16 SS x 2 #BRASST4016  
M3 Nut - Nyloc x 5 #BRASNUTM3

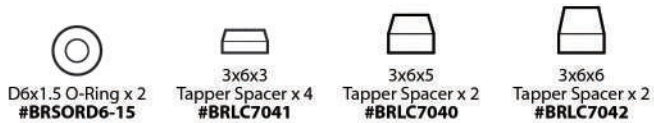

D6x1.5 O-Ring x 2 #BRSOR6-15  
3x6x3 Tapper Spacer x 4 #BRLC7041  
3x6x5 Tapper Spacer x 2 #BRLC7040  
3x6x6 Tapper Spacer x 2 #BRLC7042

**C LEAF SPRINGS**



M2.5x14 RS x 2 #BRASBH2514  
M3x6 RS x 2 #BRASBH3006  
M3x12 RS x 4 #BRASBH3012

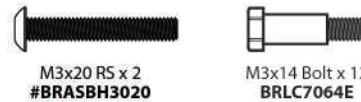

M3x20 RS x 2 #BRASBH3020  
M3x14 Bolt x 12 BRLC7064E



M2.5 Nut x 2 #BRASNUTM25  
M3 Nut - Nyloc x 16 #BRASNUTM3  
D6x1.5 O-Ring x 8 #BRSOR6-15

**A CHASSIS**



M2.5x6 CSS x 2 #BRASFH2506  
M2.5x8 CSS x 2 #BRASFH2508  
M3x6 CSS x 4 #BRASFH3006  
M3x8 CSS x 4 #BRASFH3008  
M3x10 CSS x 4 #BRASFH3010



M2.5x6 RS x 6 #BRASBH2506  
M3x6 RS x 2 #BRASBH3006  
M3x8 RS x 12 #BRASBH3008  
M3x10 RS x 4 #BRASBH3010  
M3x12 RS x 4 #BRASBH3012



ST3x14 RS x 4  
#BRASBH3014/ST

**D WHEELS**

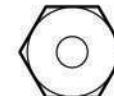

12mm Aluminum  
Wheel Hex Adapter (5mm)  
#BR113008BK



M4 Nuts - Nyloc x 4  
#BRASNUTM4



M3x3 SS x 4  
#BRASST3003



D2x10 Pin x 4  
#BRASPIN210



(Not included in Builder's Kit BR8011)

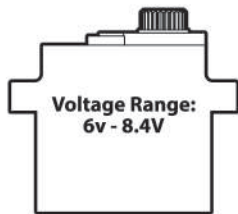

JX Waterproof HV Mini Servo x 1  
#JX/PDI-HV1151MG

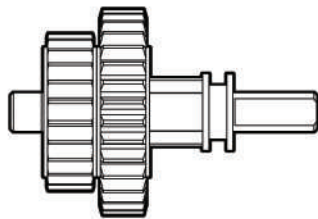

2-Speed Gear Unit x 1  
#BRLC7044E



Spur Gear Mount x 1  
#BRLC7030

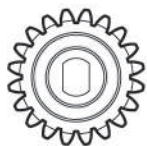

Spur Gear 20T x 2  
#BRLC7029-20T



Bearing Holder x 1  
#BRX020029A

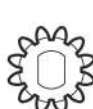

Spur Gear 12T x 1  
#BRLC7029-12T

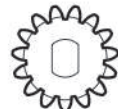

Spur Gear 15T x 1  
#BRLC7029-15T



D7x11x3 Ball Bearing x 1  
#BBZMR1172R5



D5x11x4 Ball Bearing x 7  
#BBZMR1152R5

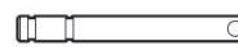

Shift Shaft x 1  
#BRLC7045C

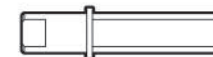

Input Shaft x 1  
#BRLC7044B

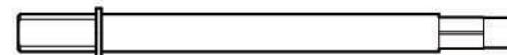

High Efficiency Output Shaft x 1  
#BRLC7209

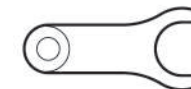

Shifter x 1  
#BRLC7045B

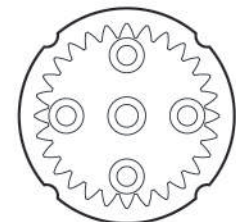

Internal Spur Gear 28T x 1  
#BRLC7031

### E GEARBOX / TRANSFER CASE



M3x8 SC x 2  
#BRASCH3008



M2.5x10 SC x 4  
#BRASCH2510



M2.5x8 SC x 8  
#BRASCH2508



M2x8 SC x 5  
#BRASCH2008



M3x10 CSS x 1  
#BRASFH3010



M3x6 CSS x 1  
#BRASFH3006



M2.5x8 CSS x 1  
#BRASFH2508



M2x5 CSS x 4  
#BRASFH2005



M3x8 RS x 4  
#BRASBH3008



M3x2.2x11 SS x 4  
#BRASST3022/DS



D2x8 Pin x 2  
#BRASPIN208



E-Clip x 2  
#BRASEC30

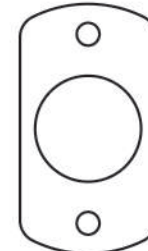

Motor Spacer x 1  
#BRLC7032



D4x7x0.5 Spacer x 1  
#BRASSPD4705



D5x8x0.5 Spacer x 9  
#BRASSPD5805



D5x8x0.1 Spacer x 5  
#BRASSPD5801

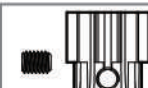

12T 32P Pinion Gear  
#BRGP3212-3

### H GEARS, SHAFTS & BEARINGS - TRANSFER CASE



Guiding Shaft x 1  
#BRLC7207-P



Rear Output Shaft x 1  
#BRLC7208



Front Output Shaft x 1  
#BRLC70201-B



20T Input Gear x 1

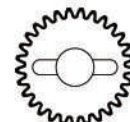

29T Spur Gear x 2  
#BRLC70210



D5x14x5 Ball Bearing x 4  
#BBZ6052R5



D4x10x4 Ball Bearing x 1  
#BBZMR1042R5



D5x10x4 Ball Bearing x 1  
#BBZMR1052R5

### I GEARS, SHAFTS & BEARINGS - GEAR BOX

### F RECEIVER BOX



M3x8 RS x 4  
#BRASBH3008



M2.5x6 RS x 2  
#BRASBH2506



M3x8 CSS x 2  
#BRASFH3008

### G SERVOS



Follower  
Horn A



Initiator  
Horn A



Spring  
Horn A

#BRLC7049



M3x6 RS x 3  
#BRASBH3006



M2x8 SC x 3  
#BRASCH2008



M3 Nut - Nylloc x 2  
#BRASNUTM3



M3x8 RS x 1  
#BRASBH3008



M3x12 RS x 1  
#BRASBH3012

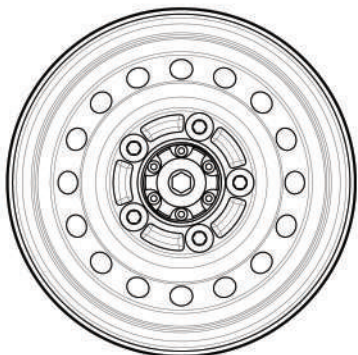

1.55" 16-Hole Classic Steelie Reversible  
Beadlock Wheels (Front)  
w/ XT504 Hubs x 2 (Gun Metal)  
**#BRW780955FGM**  
(Not included in Builder's Kit BR8011)



Rear Shackle x 2  
**#BRLC7064D**



Rear Anti-Wrap Bar Link x 2  
**#BRLC70209**

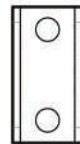

Leaf Spring Channel x 4  
**#BRLC7064G**

#BRLC70221

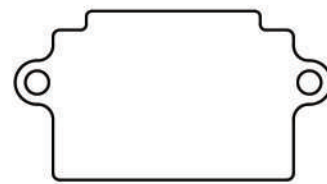

Stainless Steel Sealing Plate x 1

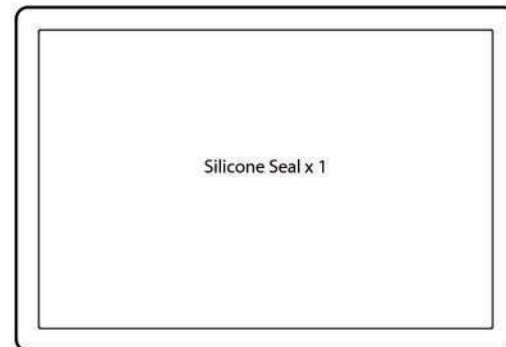

Silicone Seal x 1

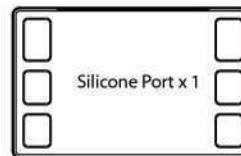

Silicone Port x 1

#BRLC70224



Front Leaf Spring Retainer  
- Outside x 2



Front Leaf Spring Retainer  
- Inside x 2

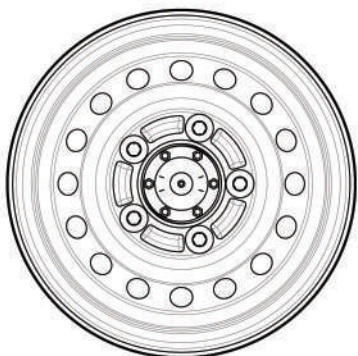

1.55" 16-Hole Classic Steelie Reversible  
Beadlock Wheels (Rear)  
w/ XT504 Hubs x 2 (Gun Metal)  
**#BRW780955RGM**  
(Not included in Builder's Kit BR8011)

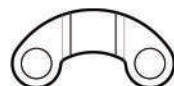

Front Leaf Spring Shackle -  
Left x 1

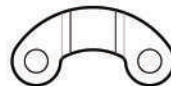

Front Leaf Spring Shackle -  
Right x 1

#BRLC70204

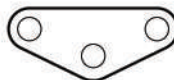

Rear Leaf Spring Retainer  
- Inside x 2



Rear Leaf Spring Retainer  
- Outside x 2

#BRLC70205

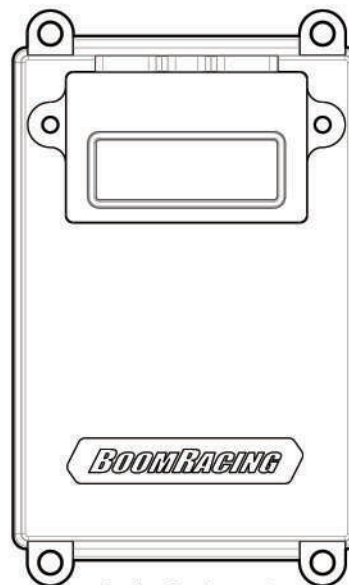

Receiver Box Cover x 1

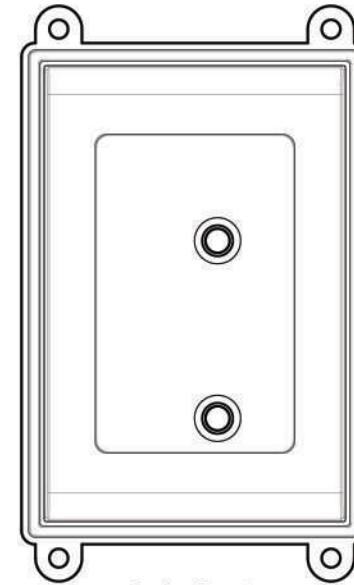

Receiver Box x 1



Joint Retainer x 8  
**#BRSHJR**



Shock End Pivot x 10  
**#BRW750310**



Front Leaf Spring Set x 2  
**#BRLC7021A**



Leaf Spring Set x 2  
**#BRLC7064A**



Extension Cable x 2  
#BRLC7059



10 x 1.5cm Double Side Tape x 1

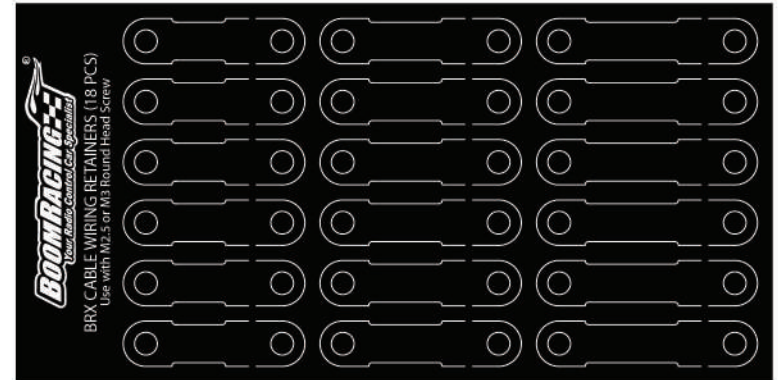

Cable Wiring Retainers  
#BRT10037

#BRT10028

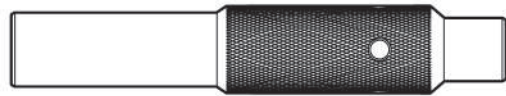

Socket 5.5mm/7mm

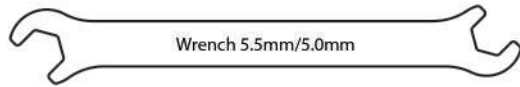

Wrench 5.5mm/5.0mm

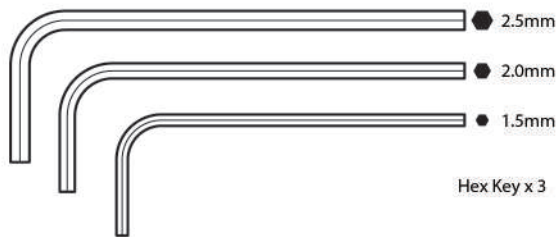

Hex Key x 3

#BRT10053

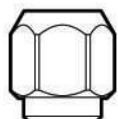

Pivot Ball Tool x 1



M3x18 RS x 1  
#BRASBH3018



Black Graphite Grease 10g x 1  
#BRGR51055-10



Silicone Grease 10g x 1  
#BRGR510274-10



30WT Shock Oil 15ml x 1  
(Available separately in 60ml)  
#BRSHK030



242 Thread Lock 2g x 1  
(Available separately in 10g)  
#BRGR5242



# 1- CHASSIS RAIL

Parts Needed:



Slotted Washer x 4



Slotted Retainer x 2

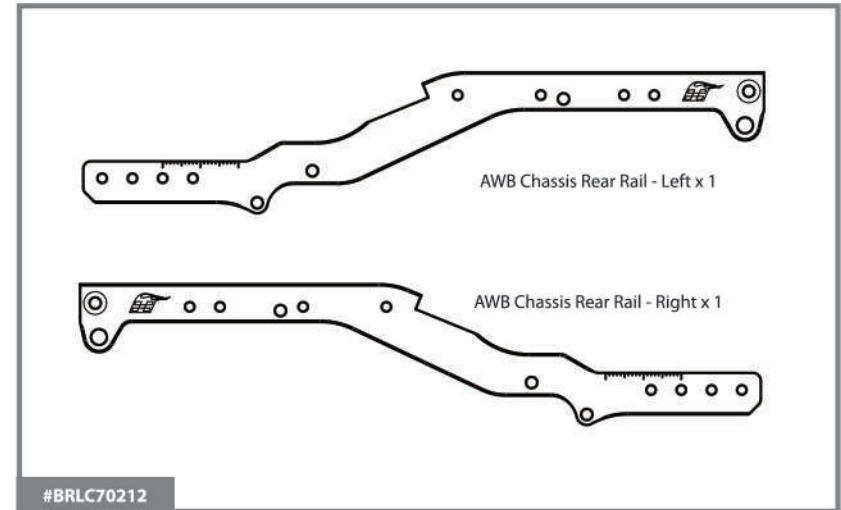
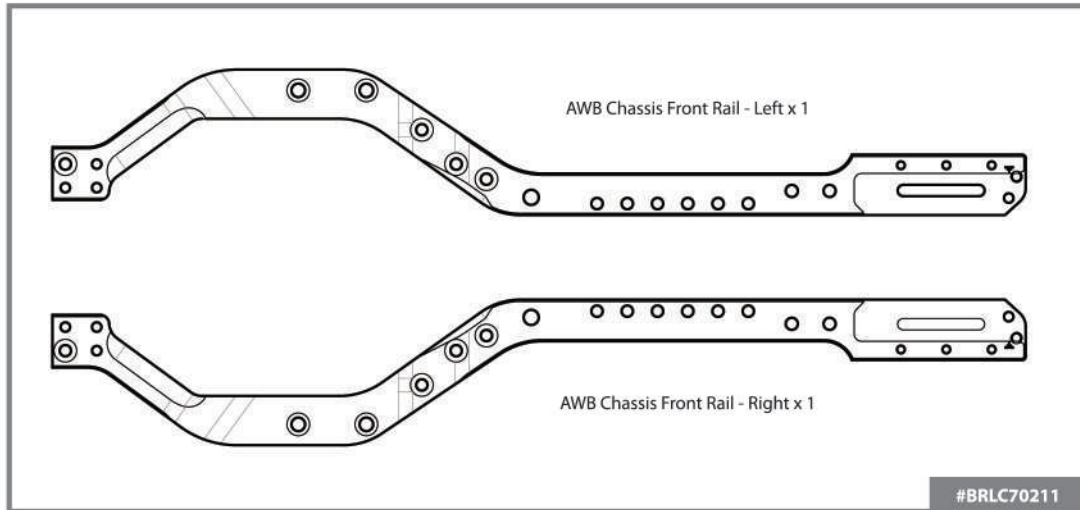
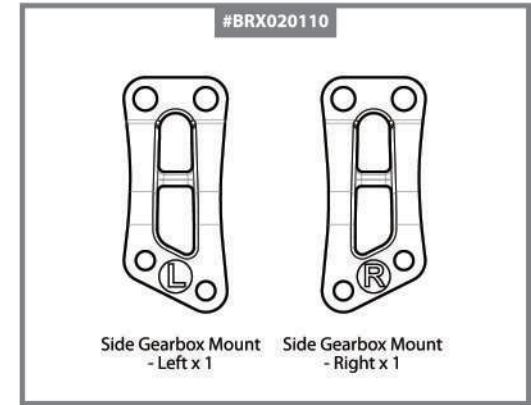
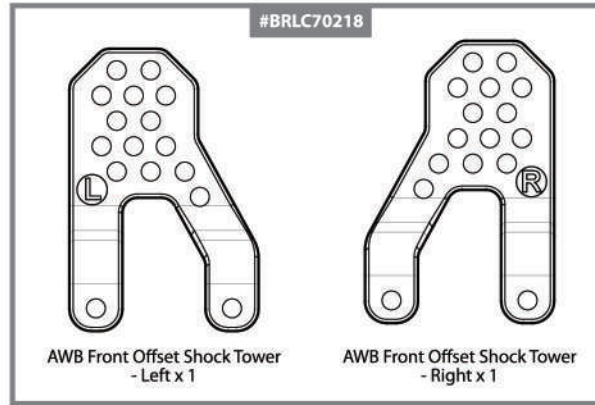
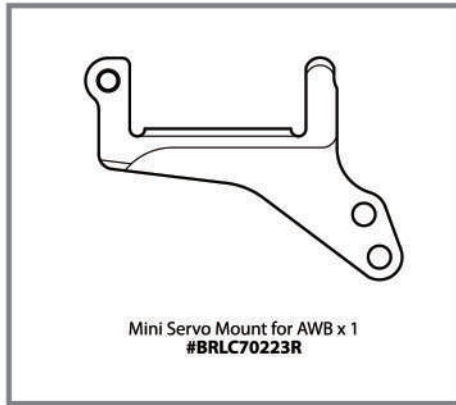

**A CHASSIS**



Apply thread lock to all screws.  
(Do not use red thread lock)



M3x8 RS x 6  
#BRASBH3008



M3x10 CSS x 4  
#BRASFH3010

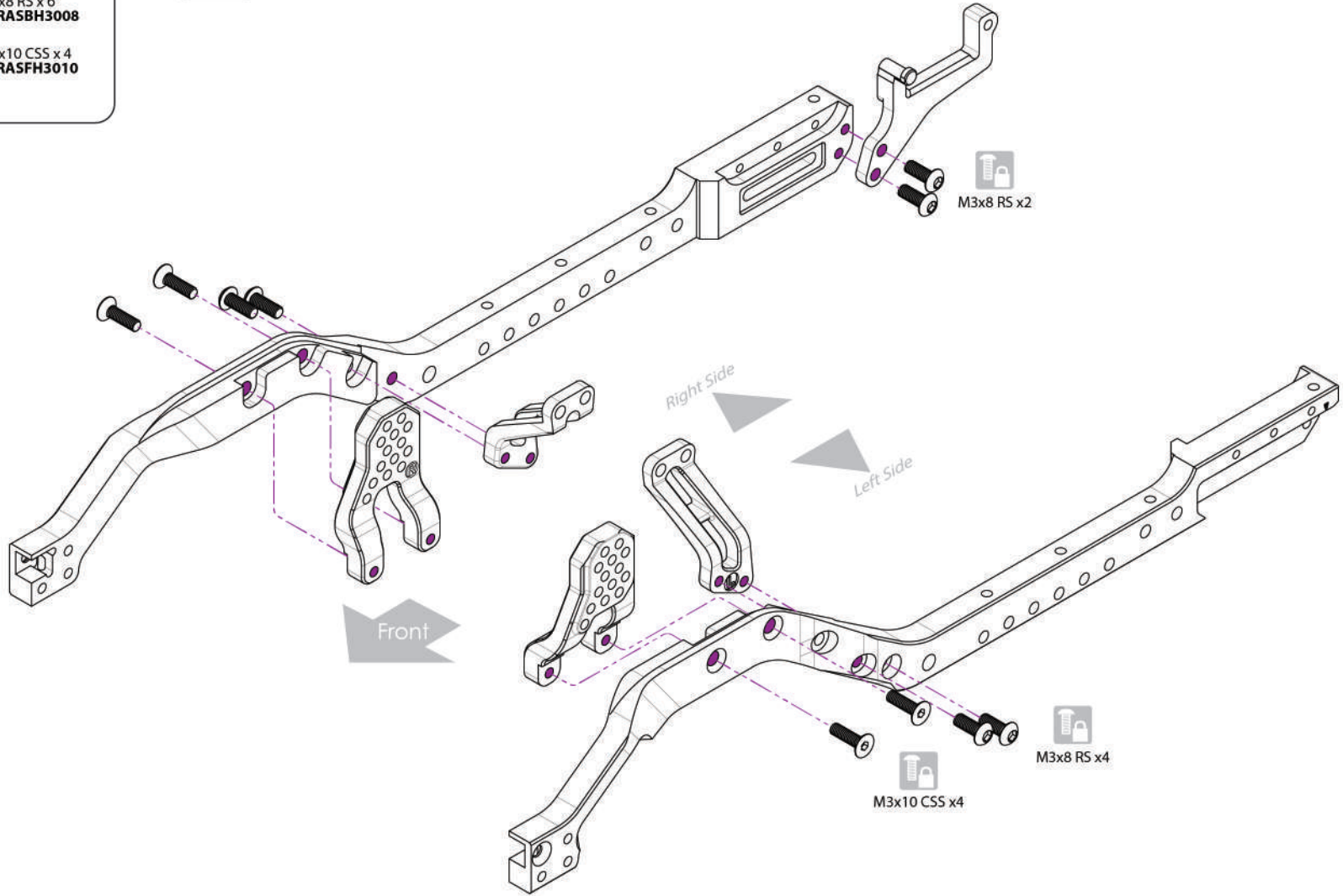

**A CHASSIS**

M3x12 RS x 4  
#BRASBH3012



Apply thread lock to all screws.  
(Do not use red thread lock)

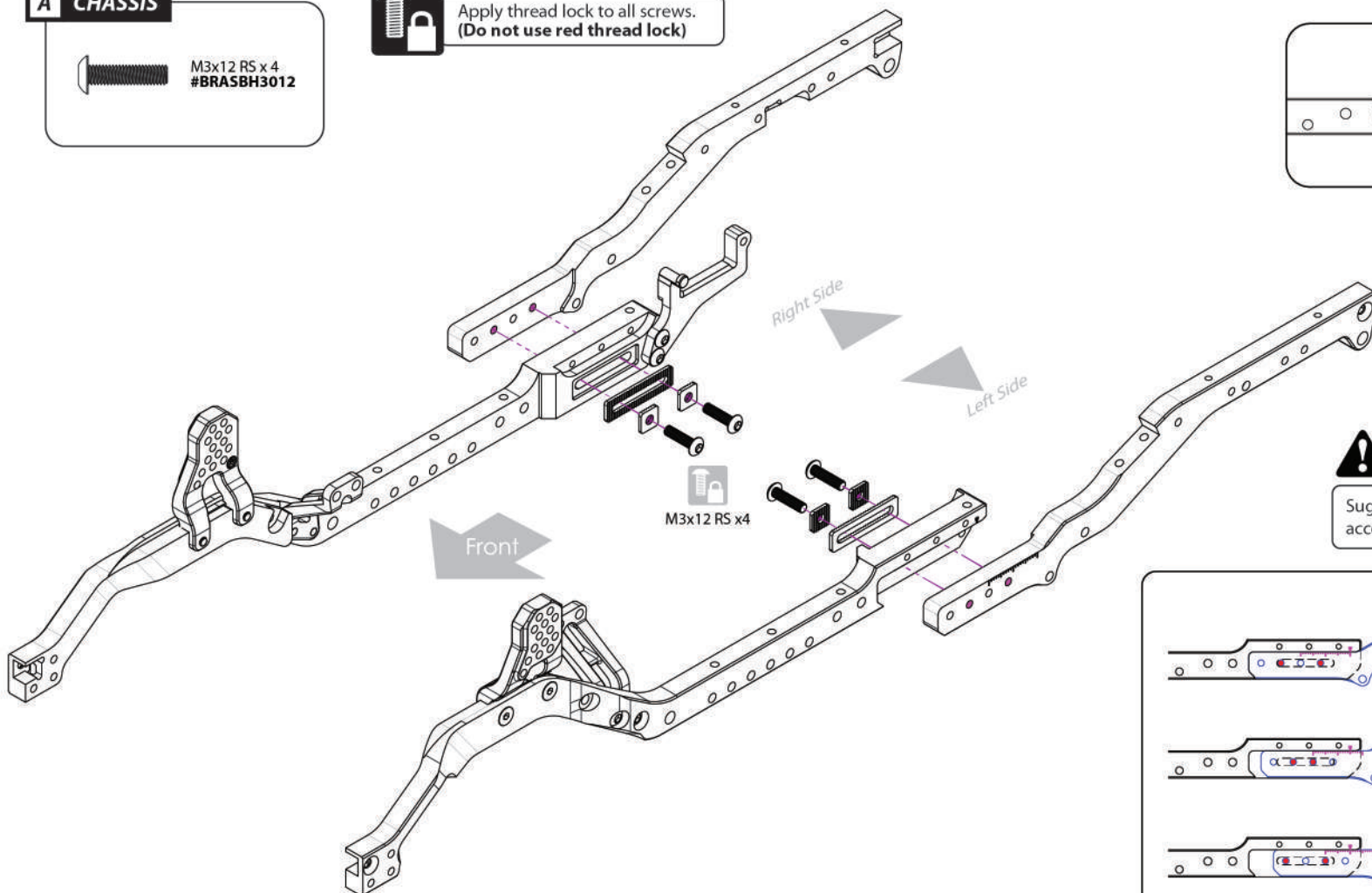
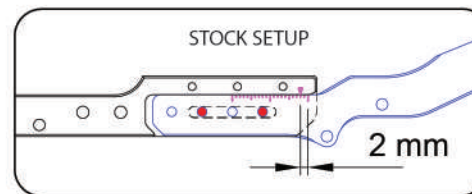

Suggested screw hole locations on the rear rails to accommodate optional chassis length configurations.

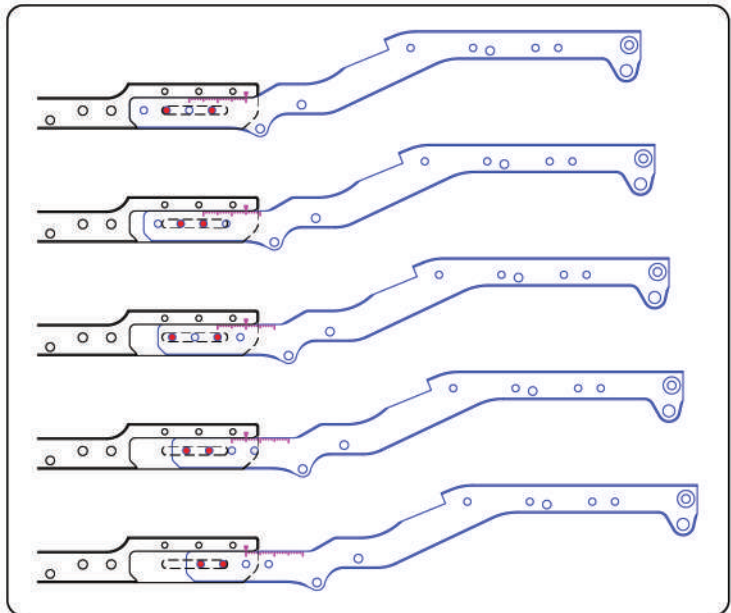

CHASSIS RAIL

CHASSIS RAIL

# 2 - CHASSIS

Parts Needed:

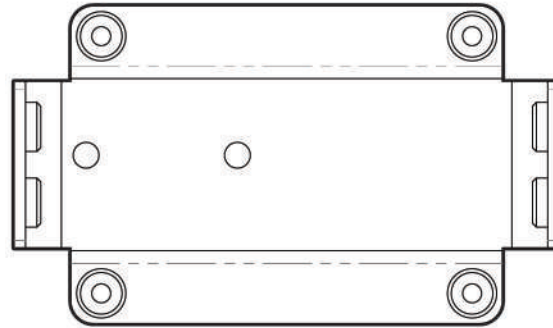

Center Skid Plate x 1  
#BRX020020LF



Steering Servo Mount for CMS Setup x 1  
#BRLC7016

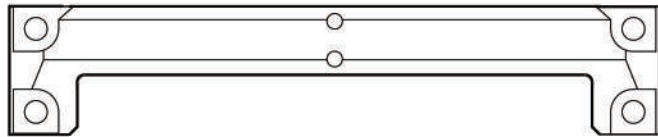

Middle Crossmember x 1  
#BRLC7014



Center Crossmember for BRLC7064 Leaf Spring x 1  
#BRLC7064B

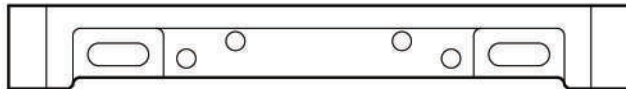





AWB Rear Crossmember x 1  
#BRLC70206

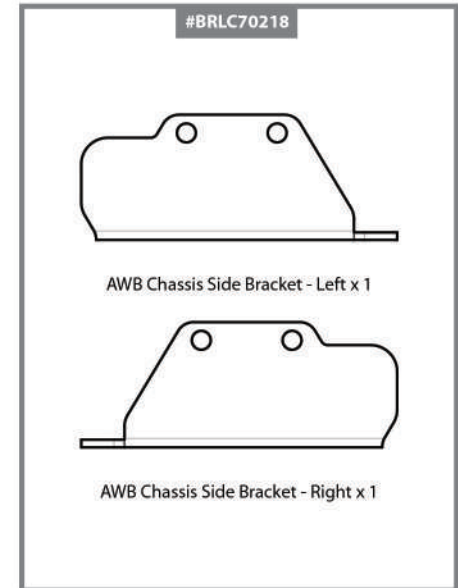

AWB Front Crossmember x 1  
#BRLC70202



**A CHASSIS**

-  M3x8 RS x 6  
#BRASBH3008
-  M3x10 RS x 4  
#BRASBH3010
-  M2.5x8 CSS x 2  
#BRASFH2508
-  M3x8 CSS x 4  
#BRASFH3008

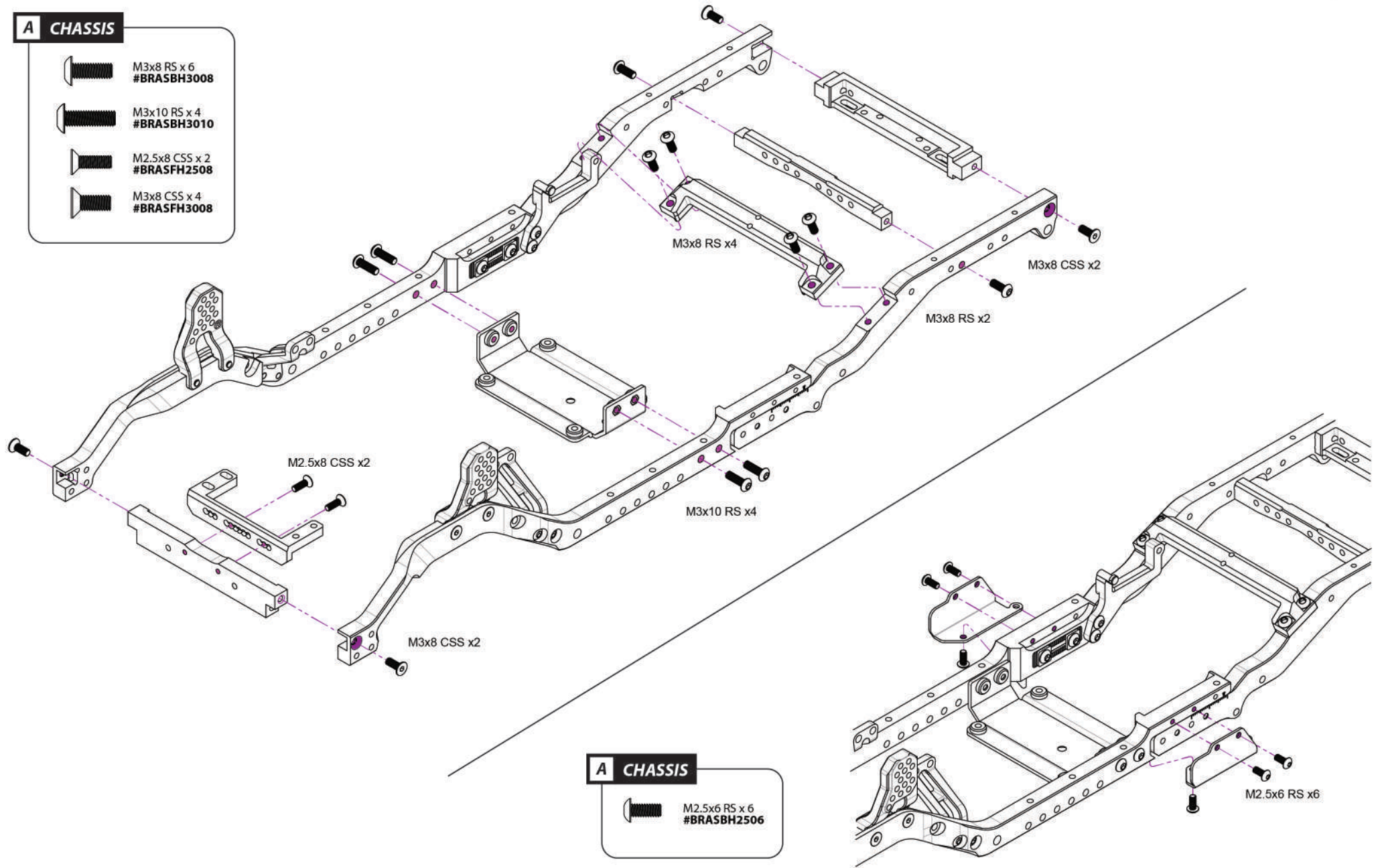

# 3 - GEARBOX

Parts Needed:

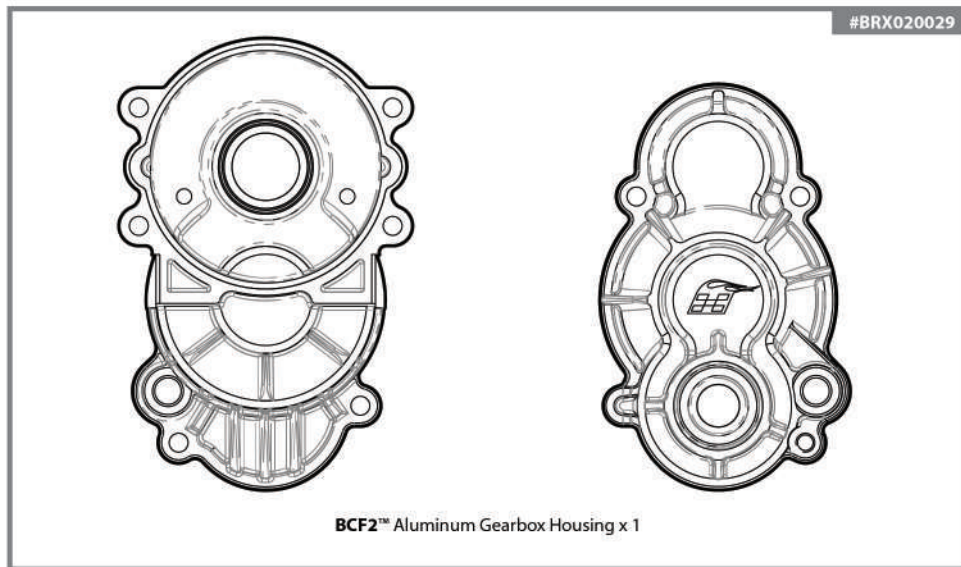

BCF2™ Aluminum Gearbox Housing x 1

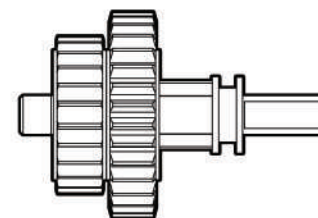

2-Speed Gear Unit x 1  
#BRLC7044E

## I GEARS, SHAFTS & BEARINGS - GEAR BOX

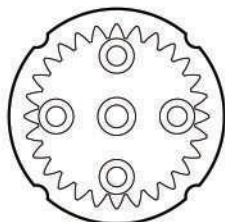

Internal Spur Gear 28T x 1  
#BRLC7031



Spur Gear Mount x 1  
#BRLC7030



Spur Gear 12T x 1  
#BRLC7029-12T

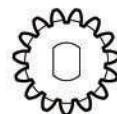

Spur Gear 15T x 1  
#BRLC7029-15T

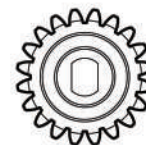

Spur Gear 20T x 2  
#BRLC7029-20T



D5x11x4 Ball Bearing x 7  
#BBZMR1152RS



D7x11x3 Ball Bearing x 1  
#BBZMR1172RS

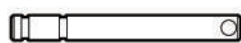

Shift Shaft x 1  
#BRLC7045C

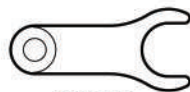

Shifter x 1  
#BRLC7045B



Input Shaft x 1  
#BRLC7044B

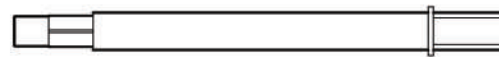



Output Shaft x 1  
#BRLC7209



Bearing Holder x 1  
#BRX020029A

**3.1**

**E GEARBOX / TRANSFER CASE**

-  M2.5x8 CSS x 1  
#BRASFH2508
-  M2x5 CSS x 4  
#BRASFH2005

 Fit the Spur Gear Mount onto the Spur Gear by tightening M2x5 countersunk screws.

To install or remove the spur gear from the gearbox, align the spur gear as pictured and temporarily insert two M3 screws\*\* to act as stoppers.

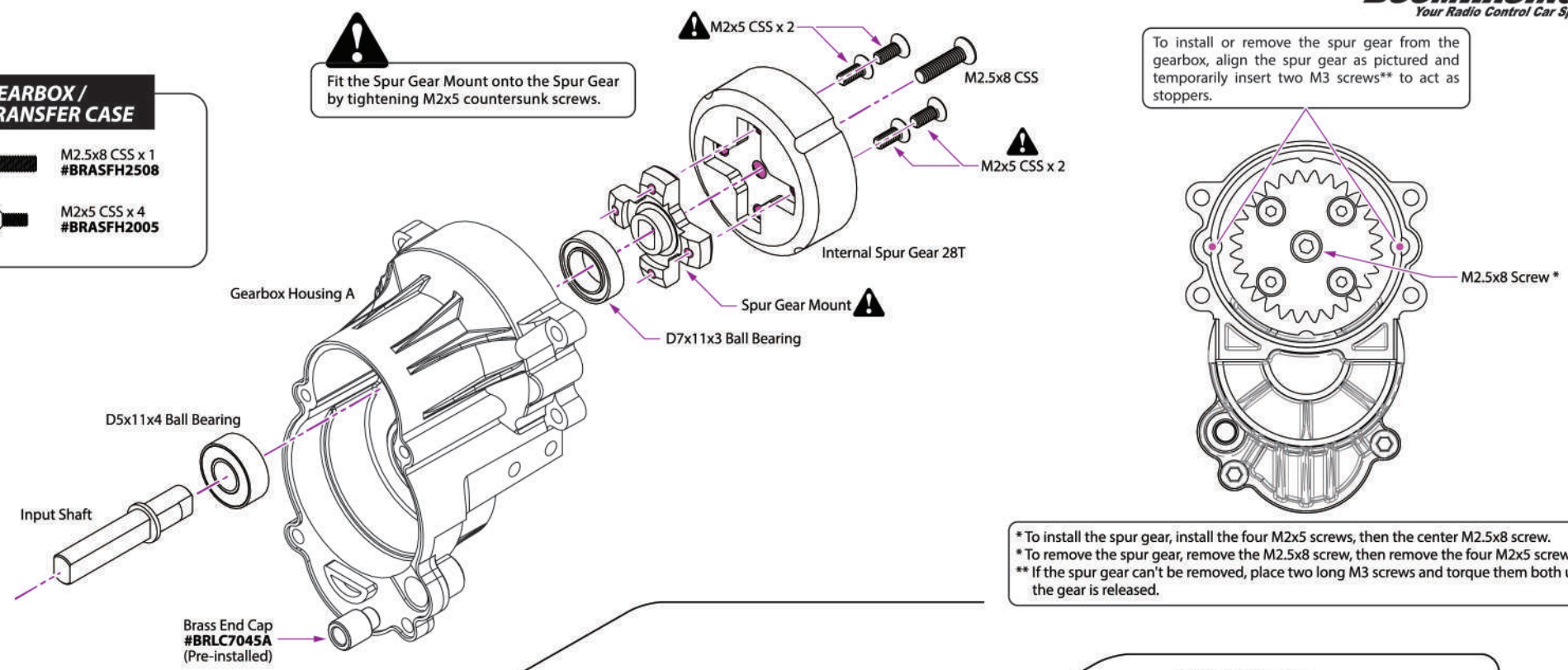

\*To install the spur gear, install the four M2x5 screws, then the center M2.5x8 screw.  
\*To remove the spur gear, remove the M2.5x8 screw, then remove the four M2x5 screws.  
\*\* If the spur gear can't be removed, place two long M3 screws and torque them both until the gear is released.

**3.2**

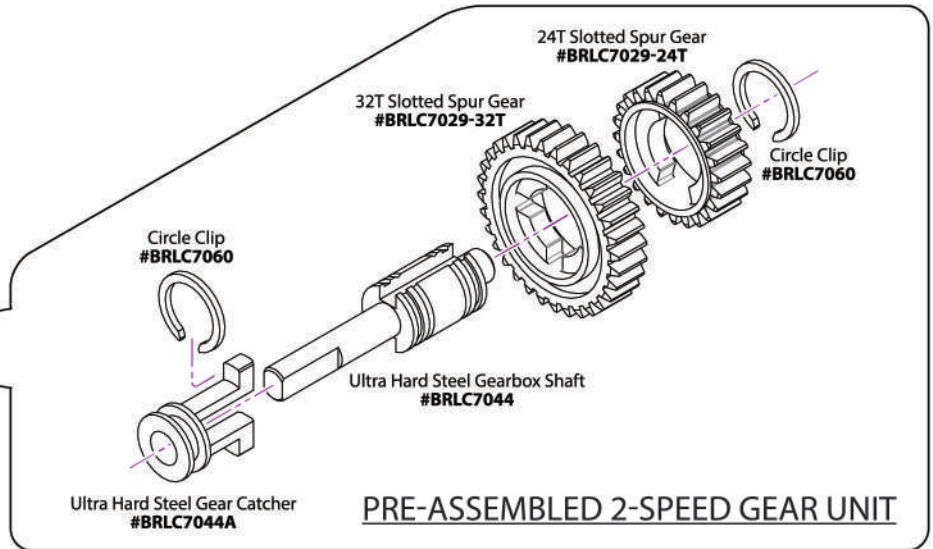
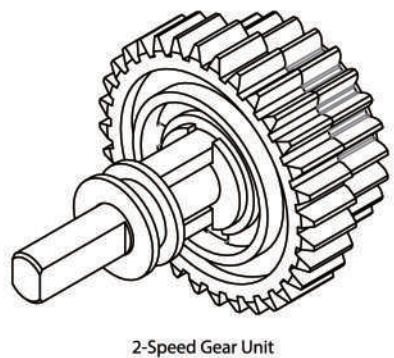

GEARBOX

GEARBOX



# 4 - TRANSFER CASE

Parts Needed:

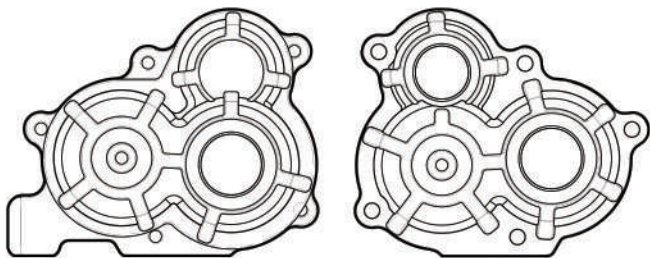

B2X™ Transfer Case Housing  
#BRX020111

## E GEARBOX / TRANSFER CASE

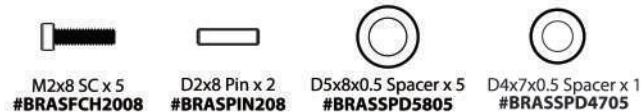

## I GEARS, SHAFTS & BEARINGS - TRANSFER CASE

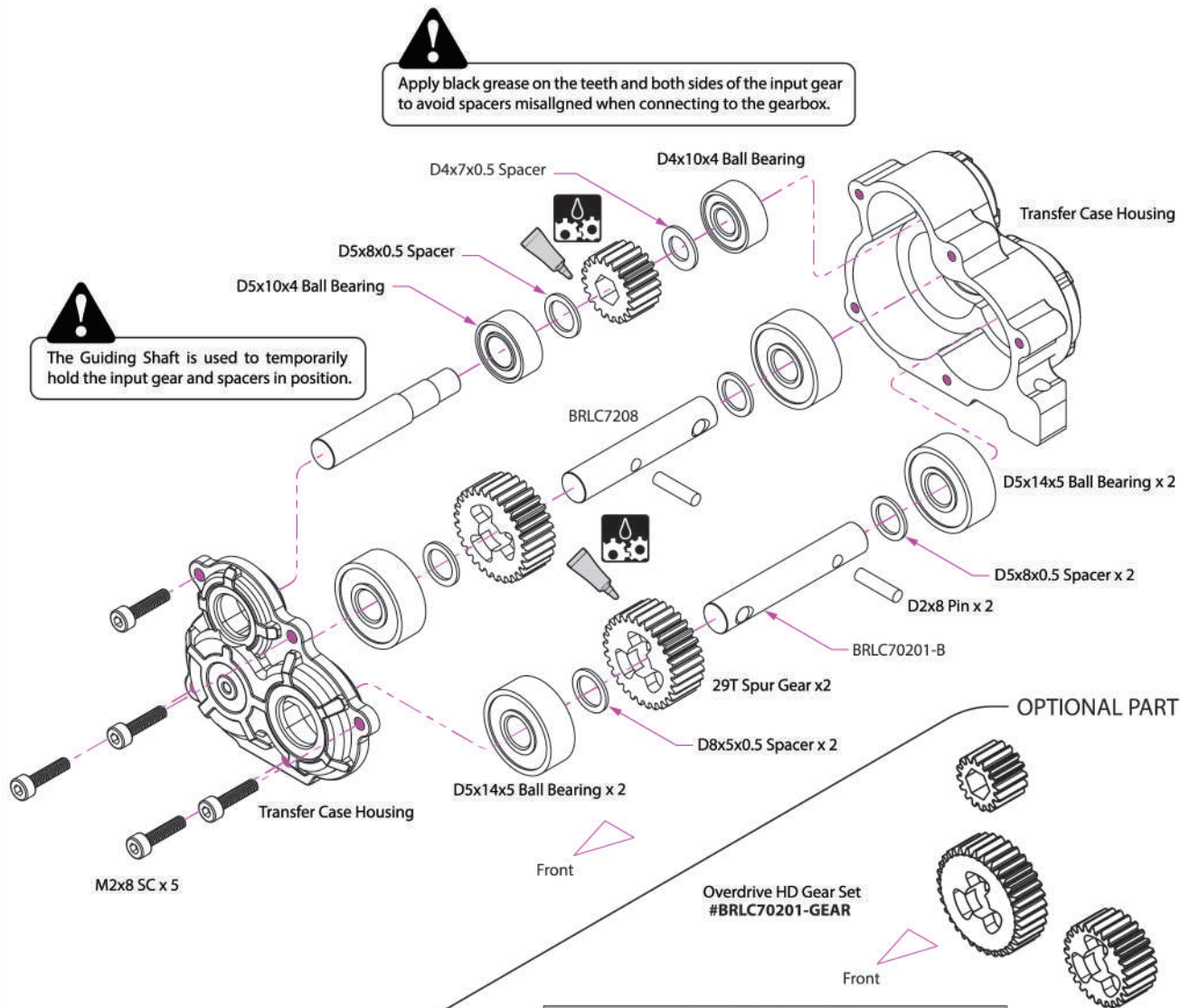
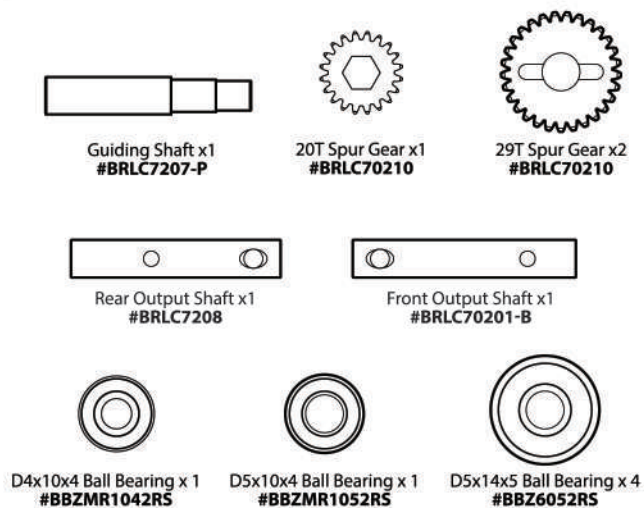

Over-Drive Gear Ratio		
Input		16T
Output - Rear	33T	1:2.06
Output - Front	25T	1:1.56
Rear to Front output speed ratio		1:1.32

TRANSFER CASE

TRANSFER CASE

# 5 - GEARBOX & TRANSFER CASE

Parts Needed:

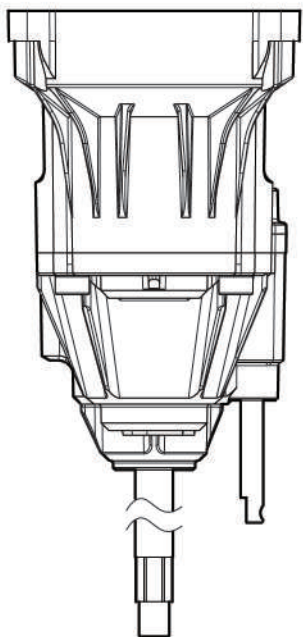

Complete **BCF2™** Gearbox

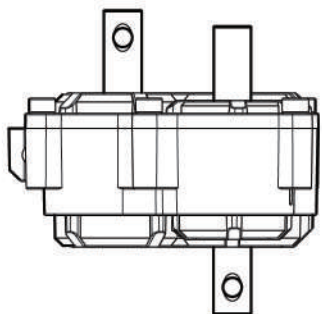

Complete **B2X™** Transfer Case

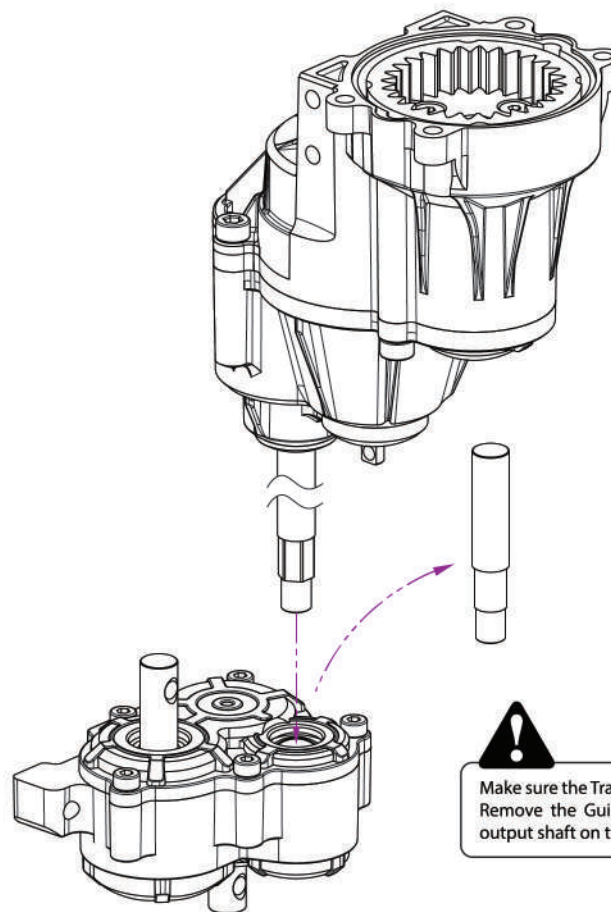

**!** Make sure the Transfer Case is kept in the upwards position. Remove the Guiding Shaft carefully and then insert the output shaft on the Gearbox into the Transfer Case.

GEARBOX & TRANSFER CASE

GEARBOX & TRANSFER CASE

**E GEARBOX / TRANSFER CASE**

-  M3x8 RS x 4  
#BRASBH3008
-  M3x6 CSS x 1  
#BRASFH3006
-  M3x10 CSS x 1  
#BRASFH3010

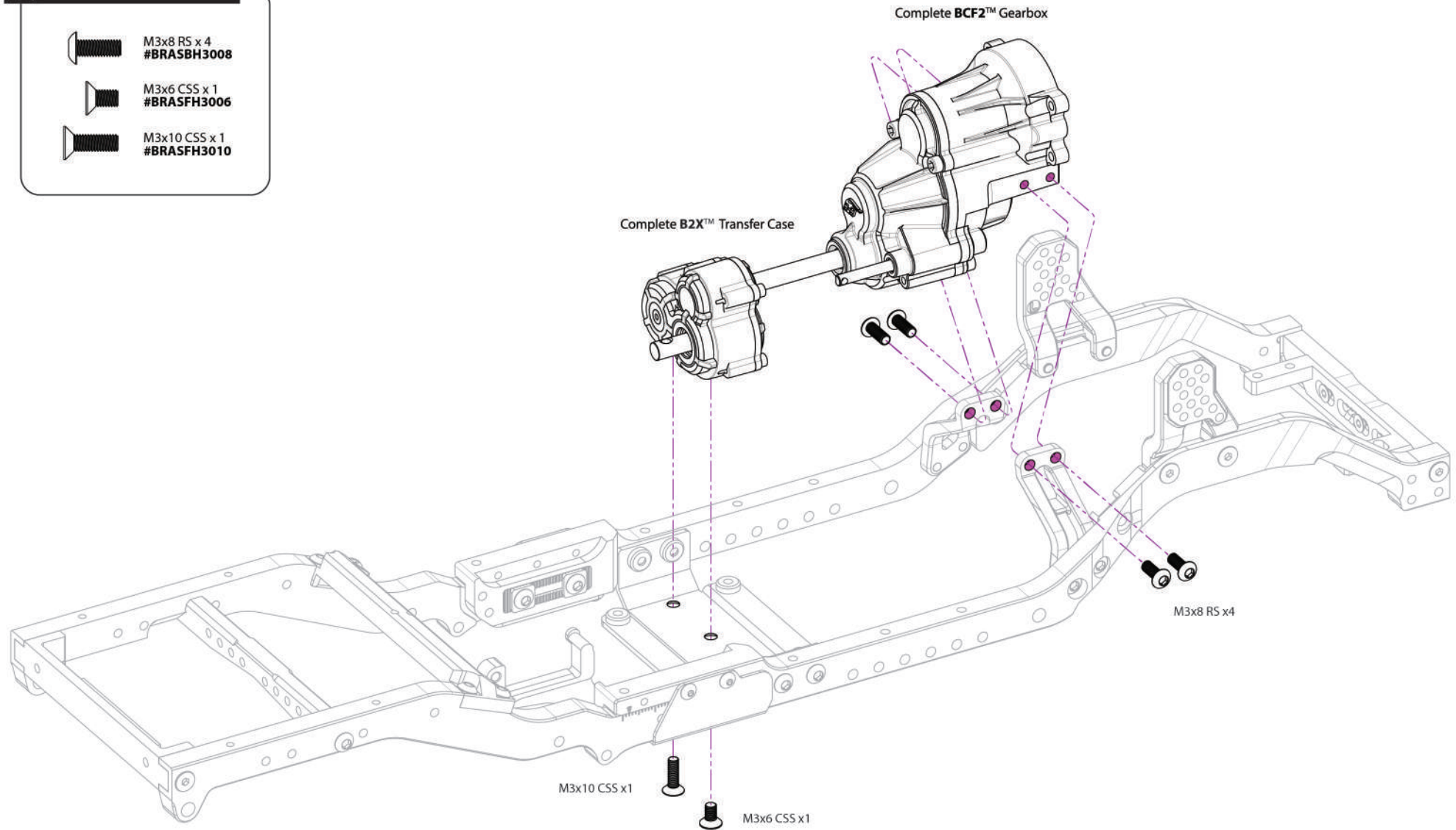

# 6 - LEAF SPRING SYSTEM



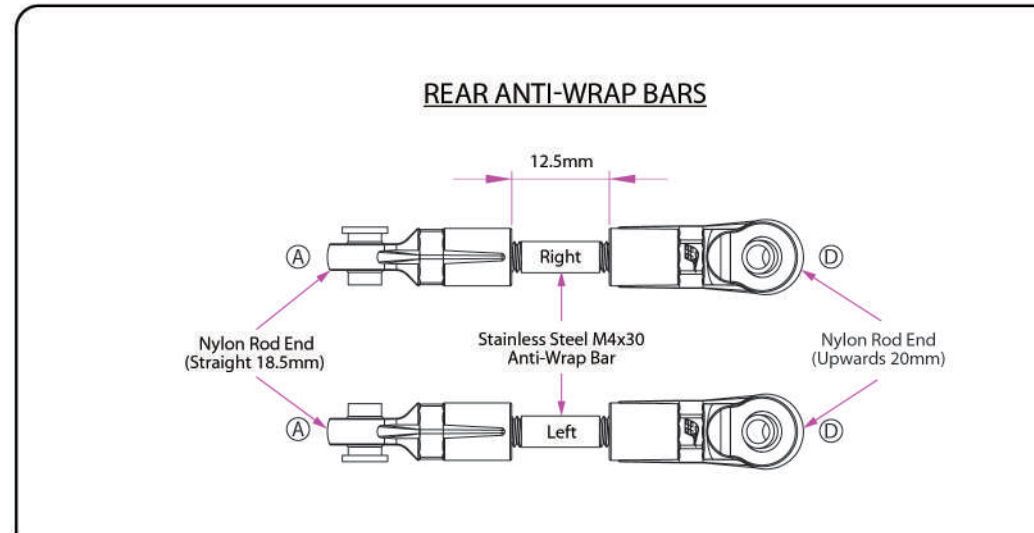
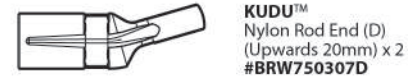
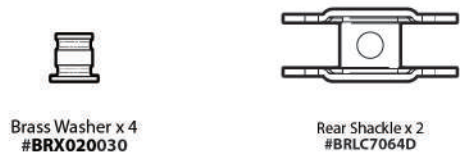
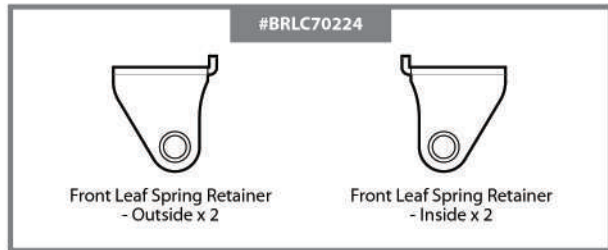
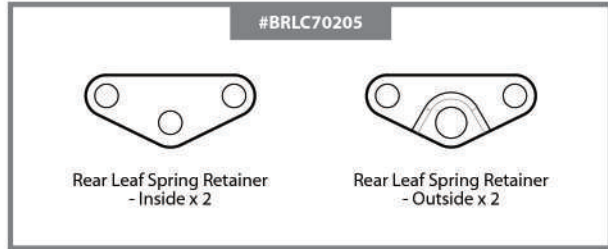
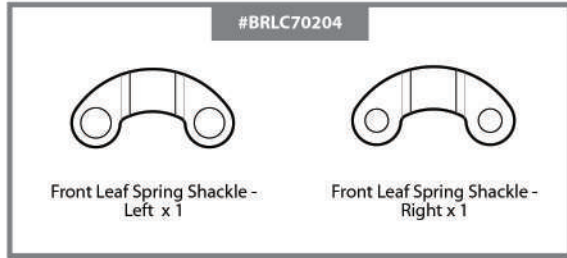

Parts Needed:



LEAF SPRING SYSTEM

LEAF SPRING SYSTEM

**C LEAF SPRINGS**

-  M3 Nut - Nylon x 8  
#BRASNUTM3
-  M3x14 Bolt x 4  
#BRLC7064E
-  M3x6 RS x 2  
#BRASBH3006
-  M3x12 RS x 2  
#BRASBH3012
-  M3x20 RS x 2  
#BRASBH3020



Pay attention to the ø4mm hole position.

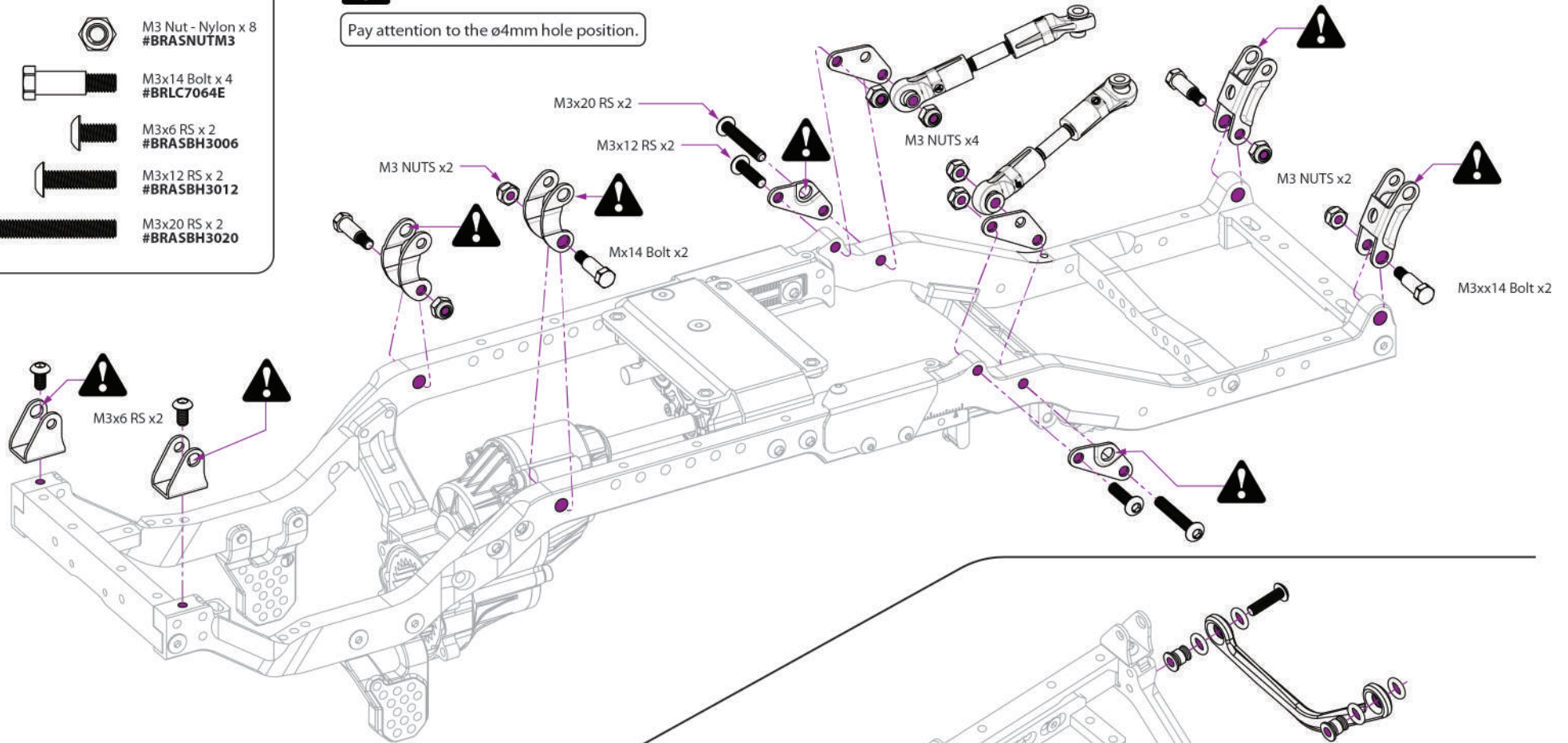

**C LEAF SPRINGS**

-  D6x1.5 O-Ring x 8  
#BRSORD6-15
-  M3x12 RS x 2  
#BRASBH3012

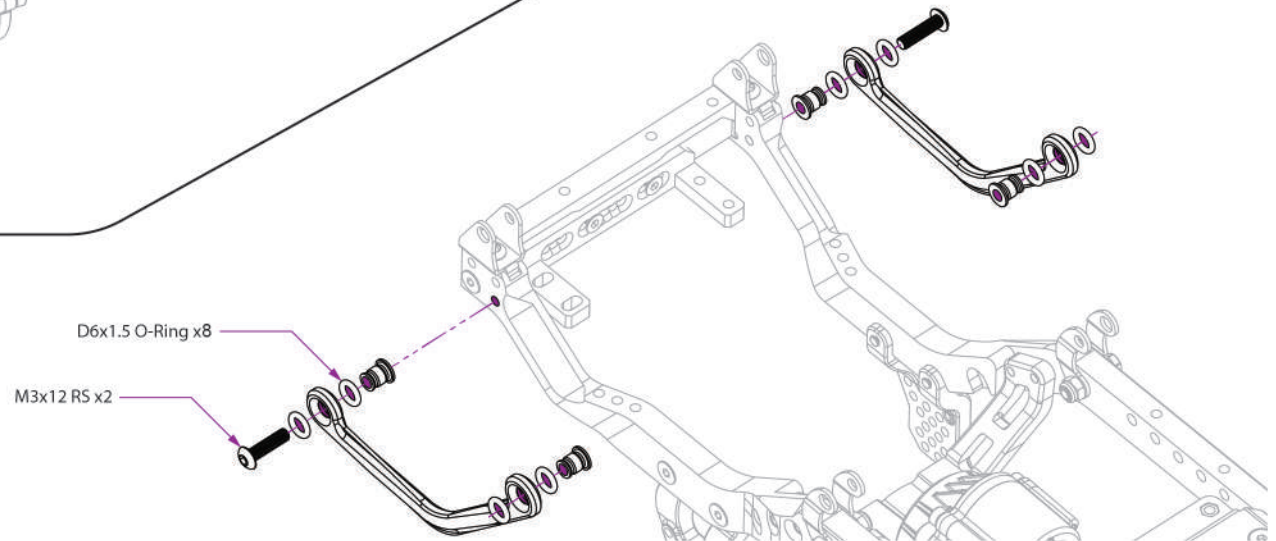

LEAF SPRING SYSTEM

LEAF SPRING SYSTEM

# 7- FRONT AXLE & LEAF SPRING

Parts Needed:

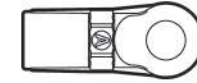
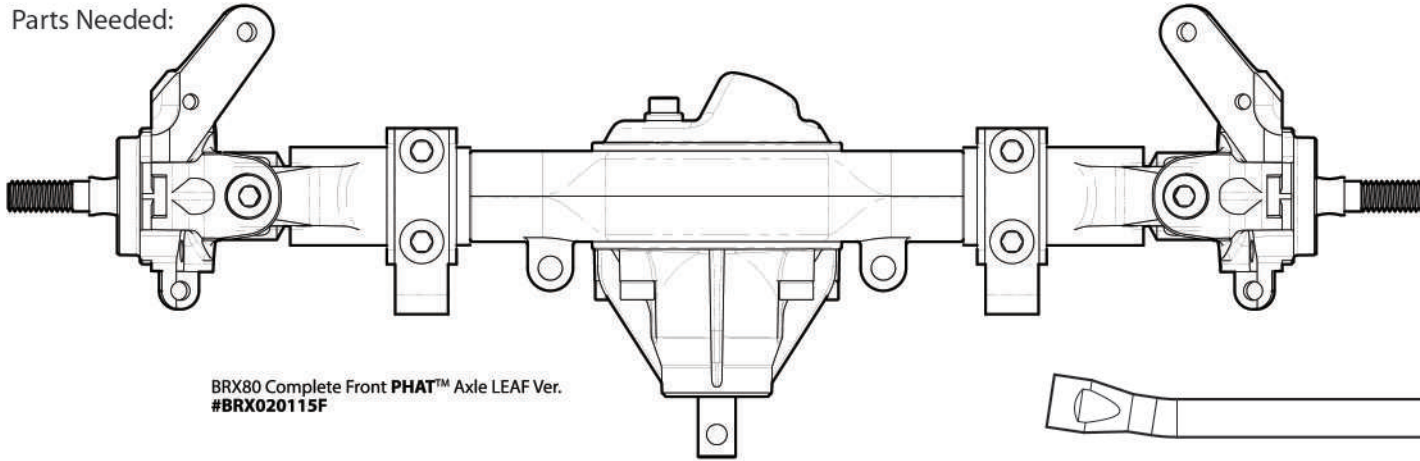

**KUDU™**  
Nylon Rod End  
(Straight 18.5mm) x 2  
#BRW750306A



**BADASS™**  
Stainless Steel Pivot Ball x 2  
#BRW750300

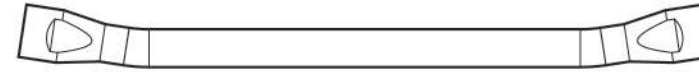

Stainless Steel Tie Rod x 1  
#BRD8022A

FRONT AXLE & LEAF SPRING

FRONT AXLE & LEAF SPRING

## B LEAFS / SHOCKS

M4x16 SS x 2  
#BRASST4016

D6x1.5 O-Ring x 2  
#BRSOR6-15

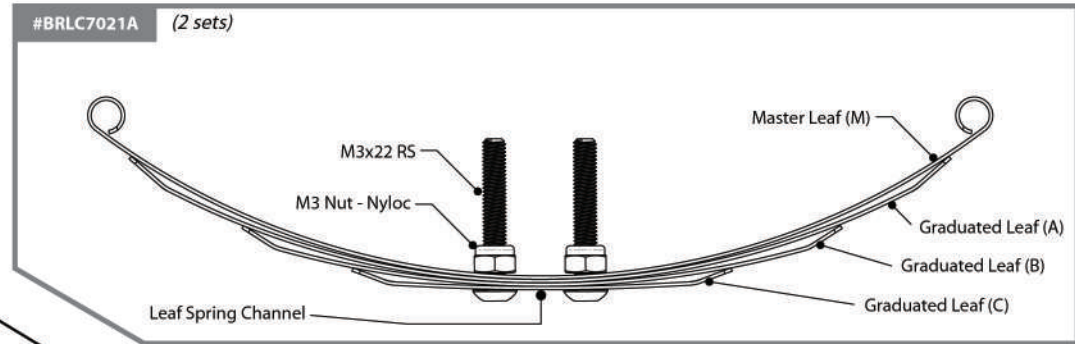

## ROD END INSTALLATION

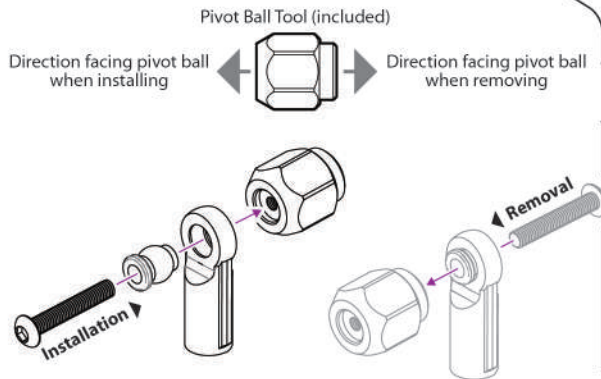

D6x1.5 O-Ring



SS Pivot Ball

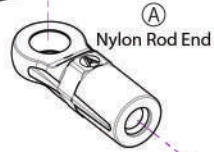

M4x16 Set Screw

TIE ROD



O-ring helps reduce tie rod from wobbling.



D6x1.5 O-Ring

M4x16 Set Screw

Stainless Steel Pivot Ball

(A) Nylon Rod End

**1**    
Add thread lock to screws on moving parts.

**LEAF SPRING LOAD SETUP** **2** 

Weight	# of Leafs	Lightest	Light	Heavy	Heaviest
Heaviest	4				(M)+(A)+(B)+(C)
Heavy	3		(M)+(B)+(C)	(M)+(A)+(C)	(M)+(A)+(B)
Light	2		(M)+(C)	(M)+(B)	(M)+(A)
Lightest	1	(M)			

 Recommended stock setup (Front).

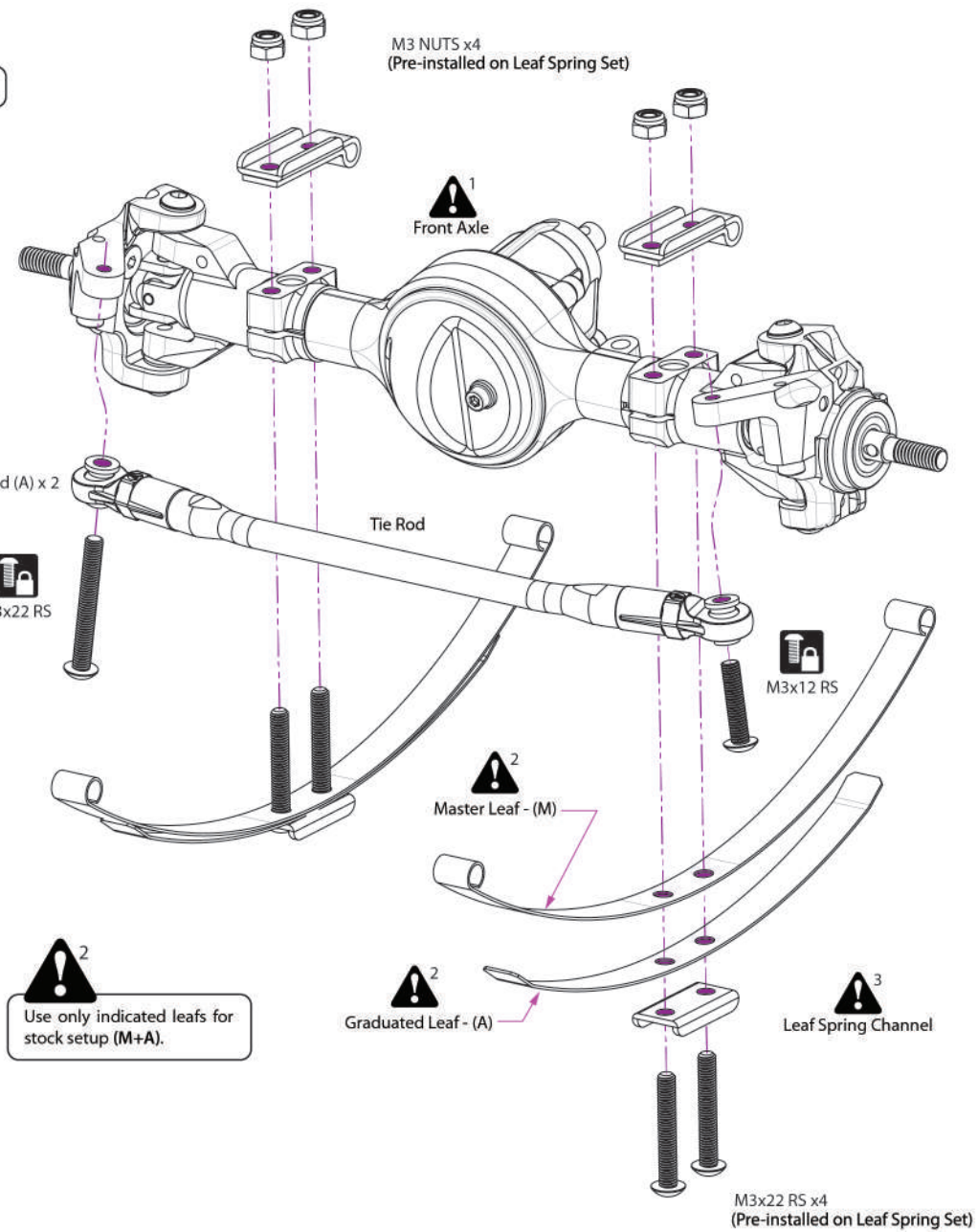

**3**  **LEAF SPRING CHANNELS**

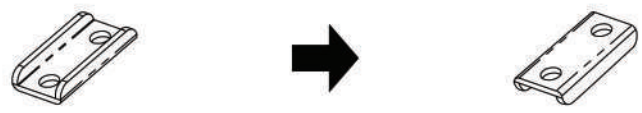

When removing one leaf, flip the Leaf Spring Channels upside down to eliminate the gap as shown above.

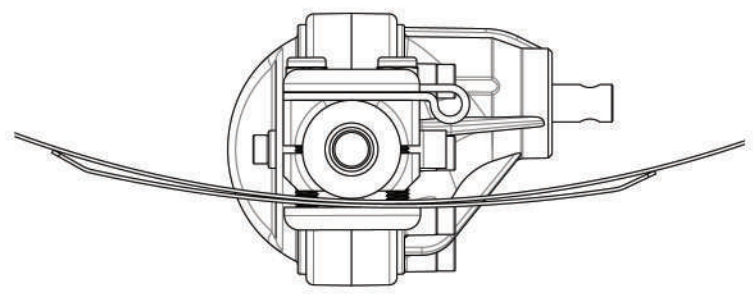

Make sure the Leaf Spring Channels are parallel to the axle mount.

**2**   
Use only indicated leafs for stock setup (M+A).

FRONT AXLE & LEAF SPRING

FRONT AXLE & LEAF SPRING

## STEERING ANGLE LIMITER INSTALLATION

### B LEAF SPRINGS



M2.5 Nut x 2



M2.5x14 RS x 2  
#BRASBH2514

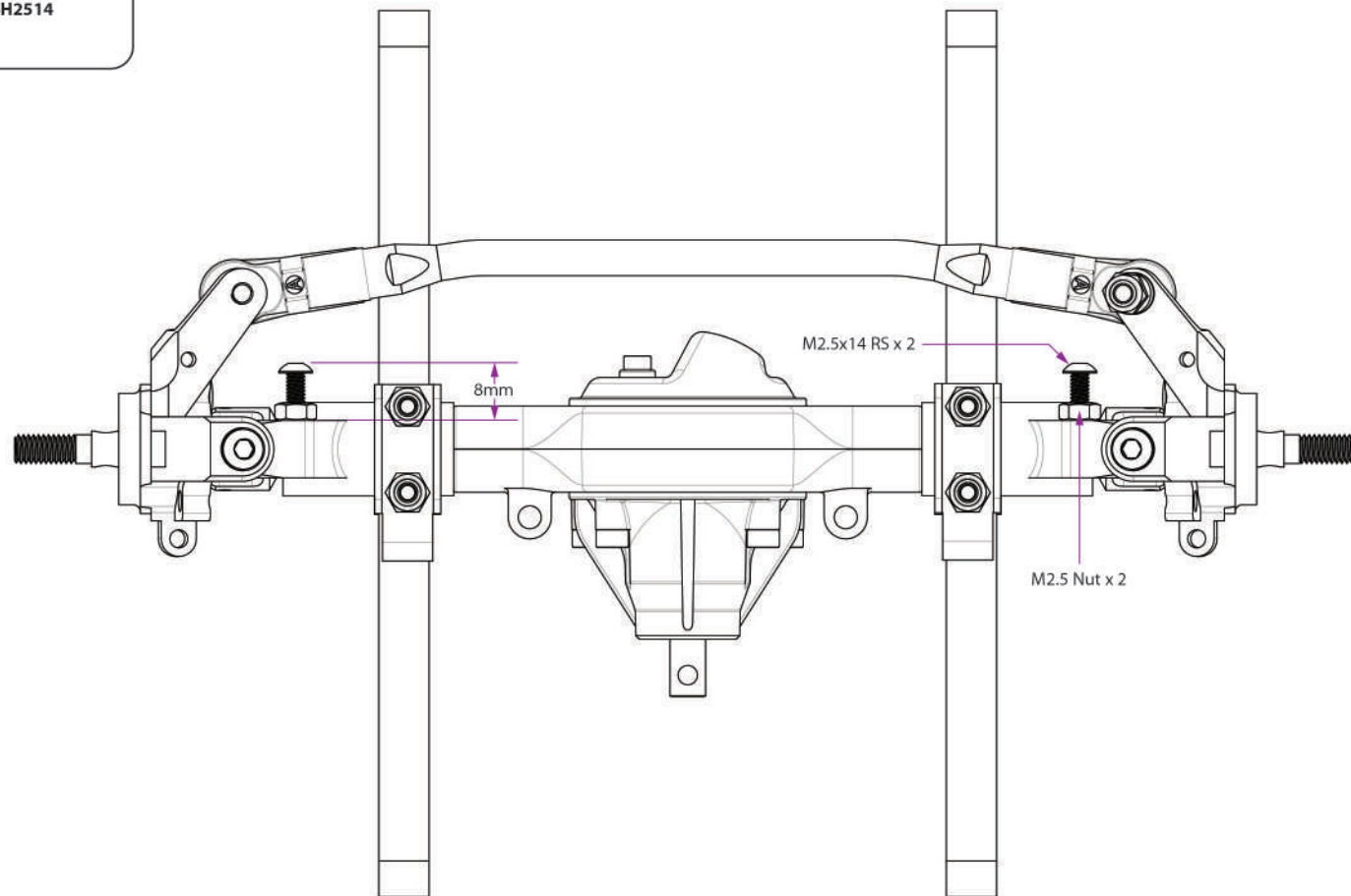

# 8 - REAR AXLE & LEAF SPRING

Parts Needed:

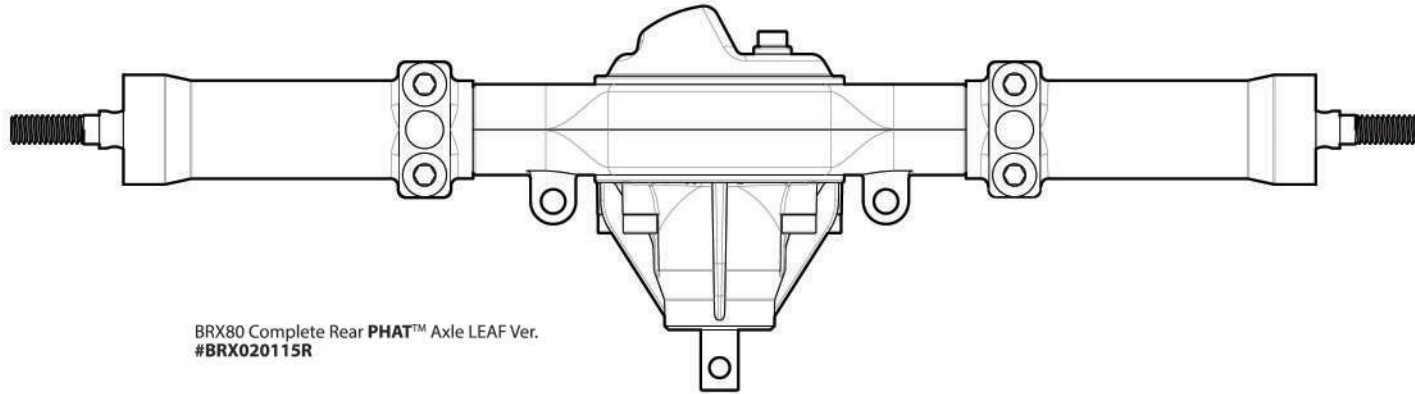

BRX80 Complete Rear PHAT™ Axle LEAF Ver.  
 #BRX020115R

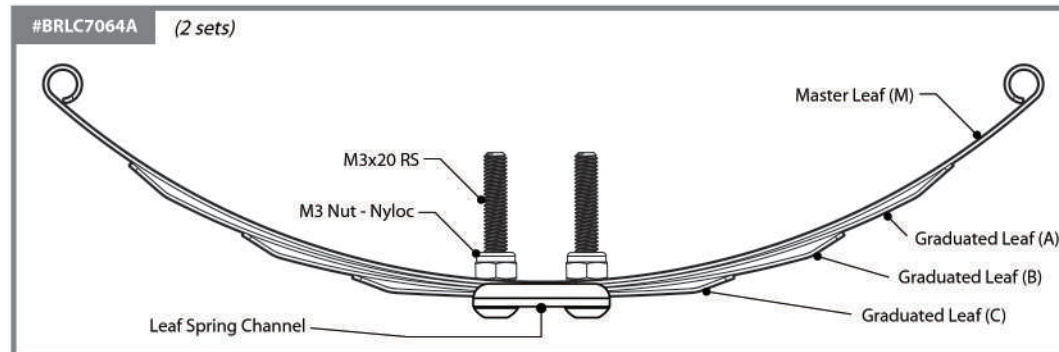

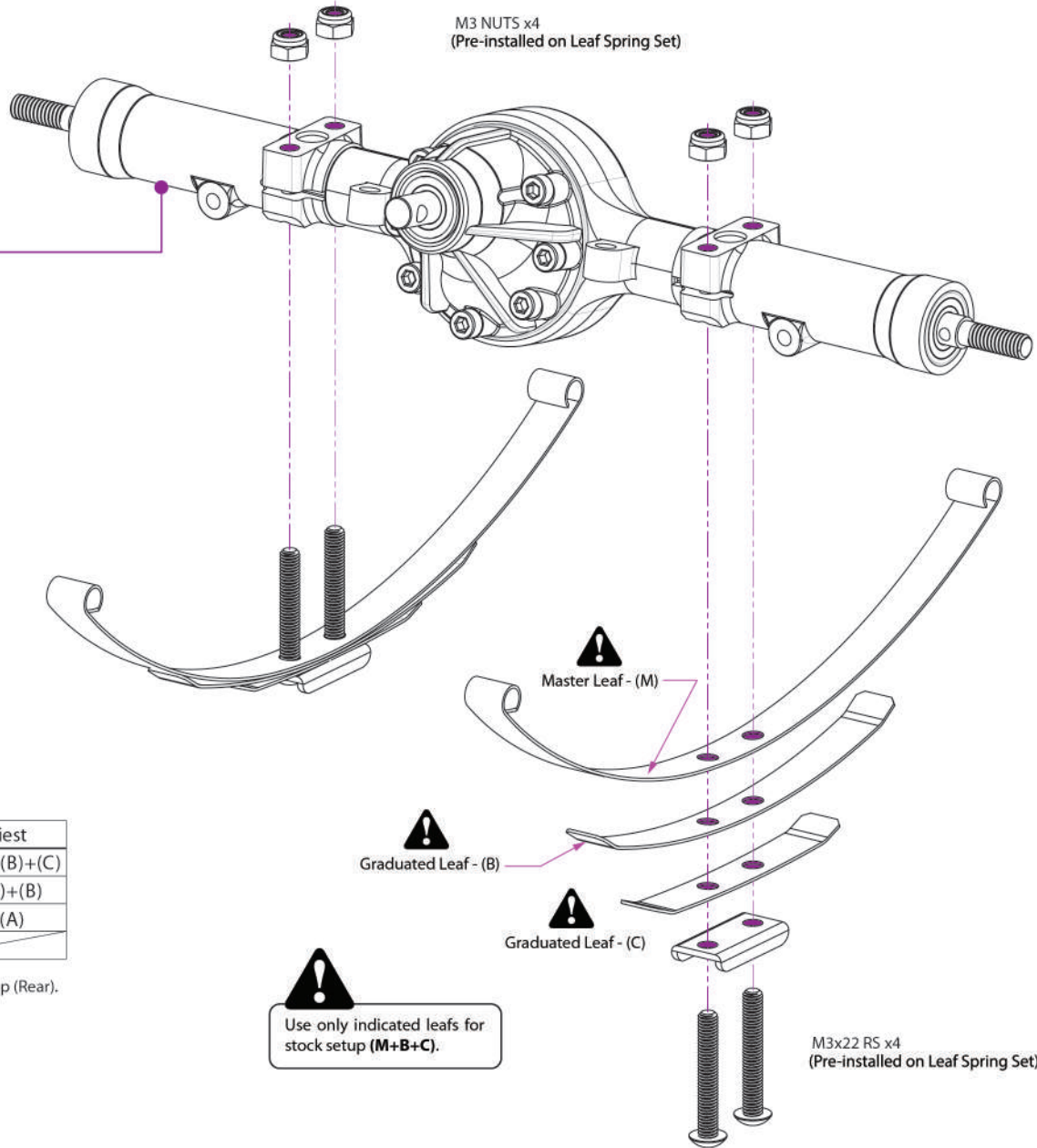
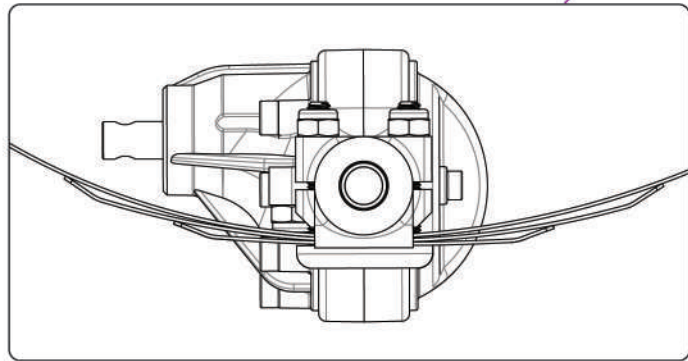

**LEAF SPRING LOAD SETUP**

Weight	# of Leafs	Lightest	Light	Heavy	Heaviest
Heaviest	4				(M)+(A)+(B)+(C)
Heavy	3		(M)+(B)+(C)	(M)+(A)+(C)	(M)+(A)+(B)
Light	2		(M)+(C)	(M)+(B)	(M)+(A)
Lightest	1	(M)			

Recommended stock setup (Rear).

Use only indicated leaves for stock setup (M+B+C).

# 9 - SHOCKS

Parts Needed:

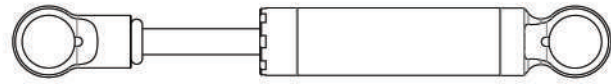

KUDU™ 70mm Scale Shock Absorbers x 4  
#BRSH0070



Joint Retainer x 8  
#BRSHJR



Shock End Pivot x 8  
#BRW750310

## SHOCKS INSTALLATION & SETUP

**1-3**  
Pay attention to cautions 1, 2 and 3.

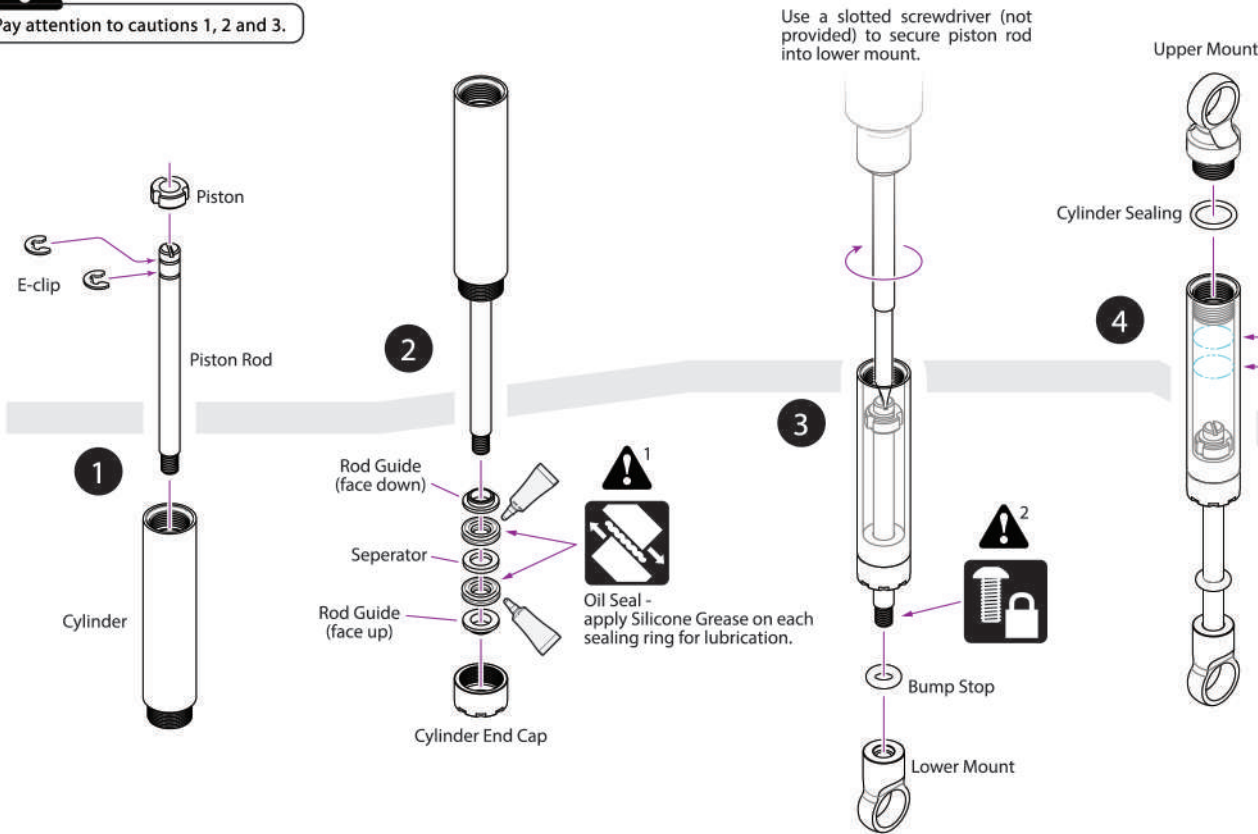

## PIVOT BALL INSTALLATION & REMOVAL

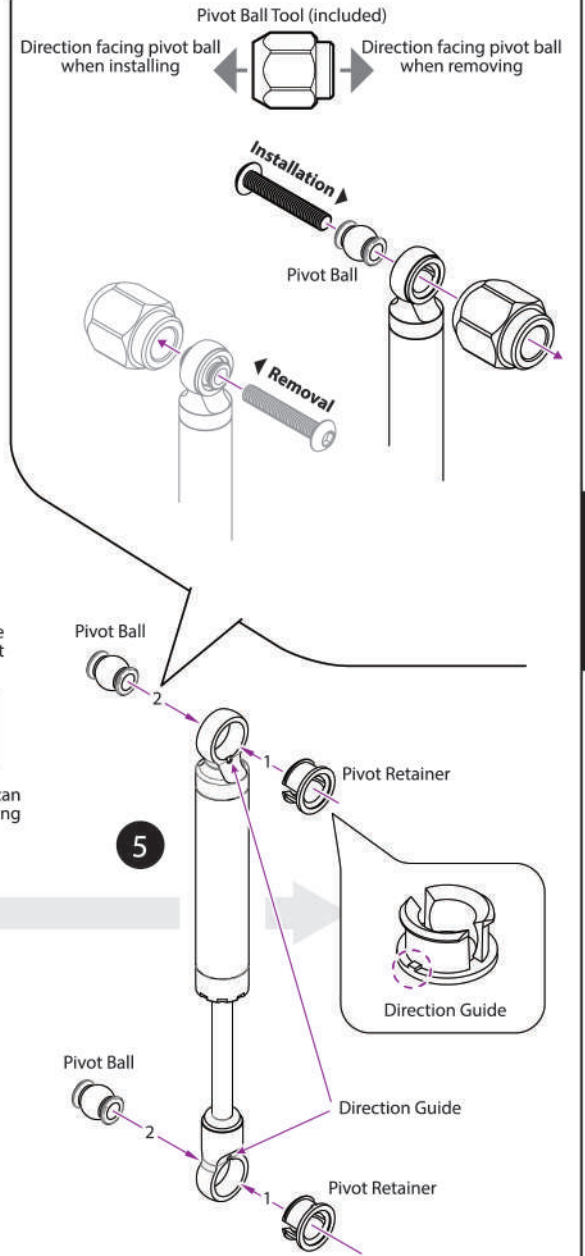

SHOCKS

SHOCKS

**B LEAFS / SHOCKS**

-  3x6x3  
Tapper Spacer x 2  
#BRLC7041
-  M3 Nut - Nylon x 2  
#BRASNUTM3
-  M3x16 RS x 2  
#BRASBH3016
-  M3x24 RS x 2  
#BRASBH3024

**C LEAF SPRINGS**

-  M3 Nut - Nylon x 4  
#BRASNUTM3
-  M3x14 Bolt x 4  
#BRLC7064E

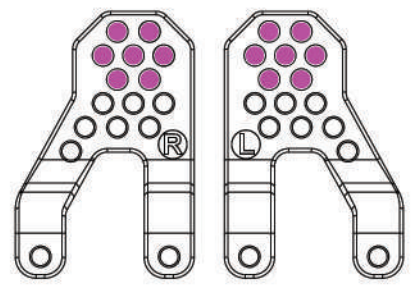

Only use highlighted holes as optional damper installation position to increase chassis ground clearance.

 Apply thread lock to all screws.  
(Do not use red thread lock)

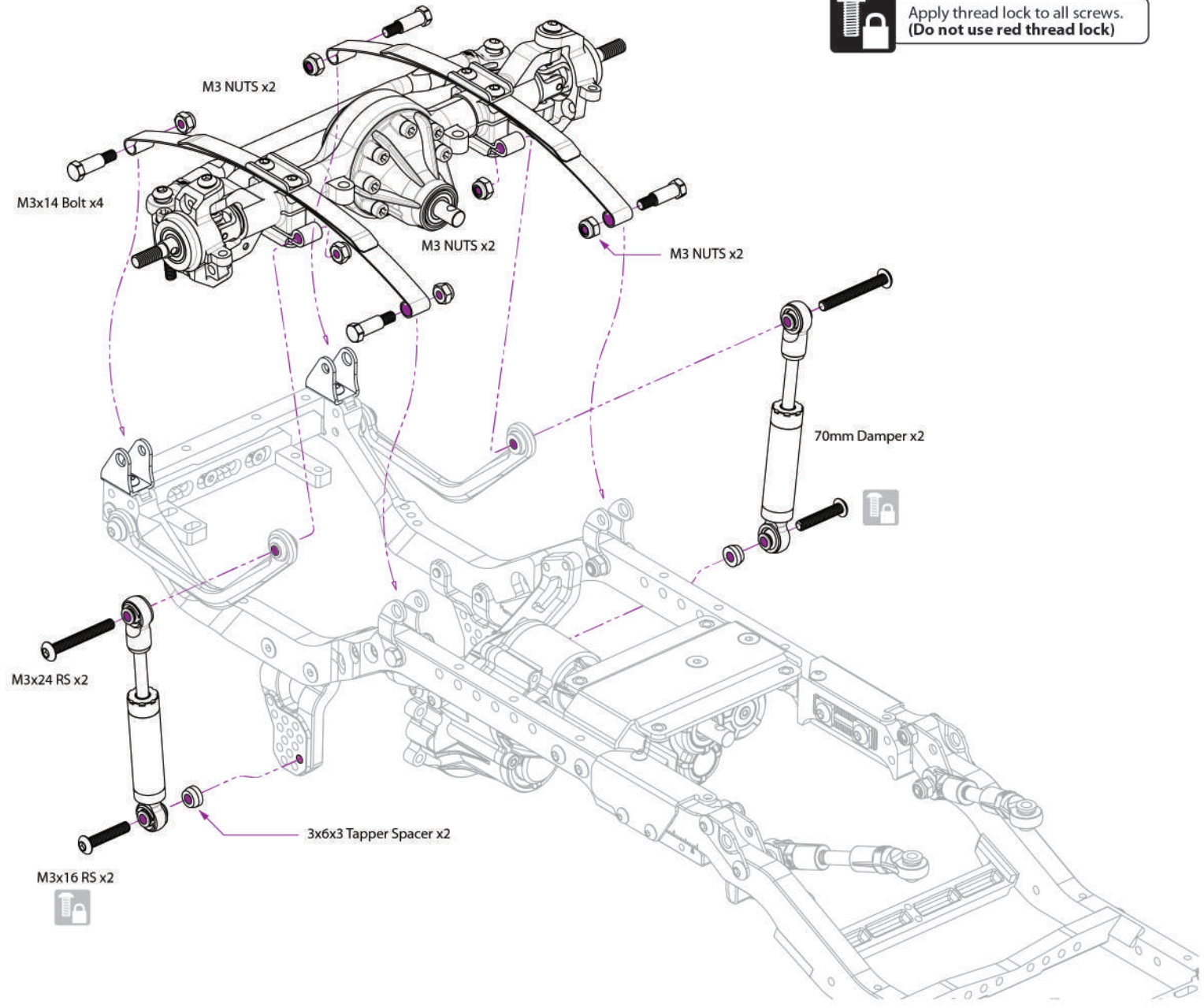

**B LEAFS / SHOCKS**

 3x6x3  
 Tapper Spacer x2  
 #BRLC7041

 3x6x5  
 Tapper Spacer x2  
 #BRLC7040



 M3x16 RS x 2  
 #BRASBH3016

 M3x20 RS x 2  
 #BRASBH3024

**C LEAF SPRINGS**

 M3 Nut - Nylon x 4  
 #BRASNUTM3

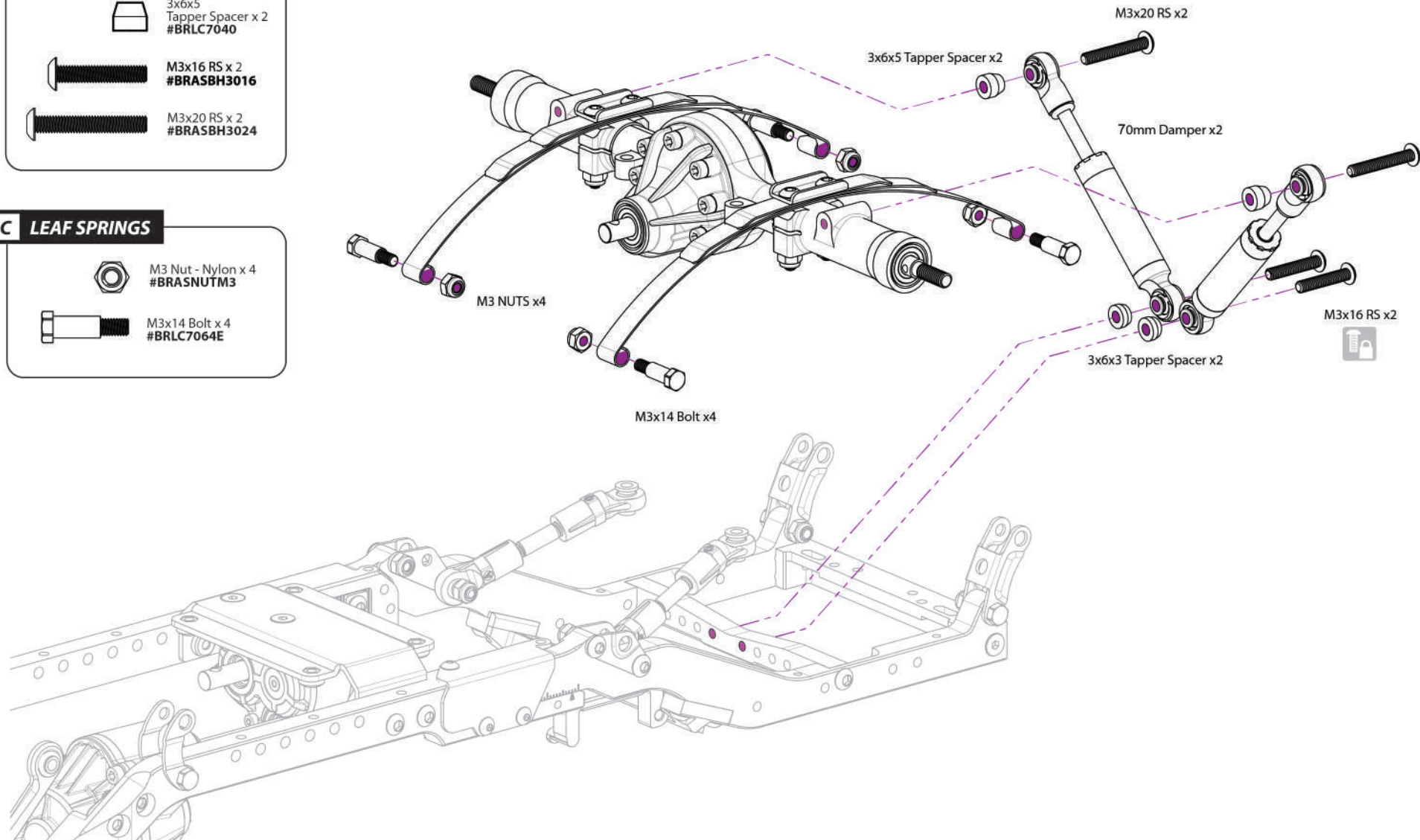
 M3x14 Bolt x 4  
 #BRLC7064E

 Apply thread lock to all screws.  
 (Do not use red thread lock)

# 10 - DRIVE SHAFTS

Parts Needed:



KUDU™ Heavy-Duty 80-90mm Steel CVD Center Drive Shaft x 1  
#BRKD003-90



KUDU™ Heavy-Duty 84-99mm Steel CVD Center Drive Shaft x 1  
#BRKD003-94

## E GEARBOX / TRANSFER CASE



M3/2.2x11 SS x 4  
#BRASST3022/DS

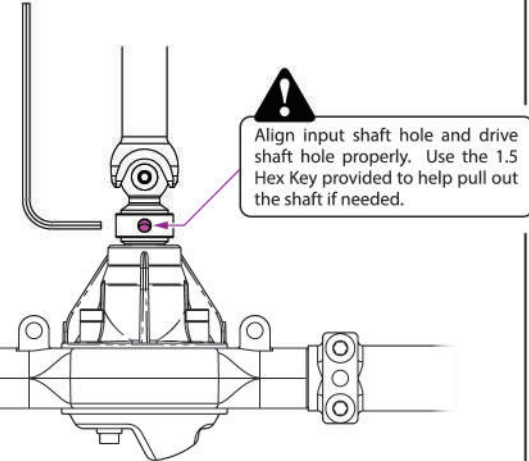

⚠️ Align input shaft hole and drive shaft hole properly. Use the 1.5 Hex Key provided to help pull out the shaft if needed.

⚠️ Routinely check the two center driveshafts and make sure loctite is used on the grub screws to prevent them from backing out.

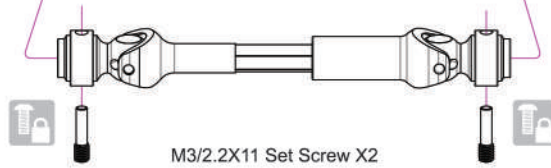
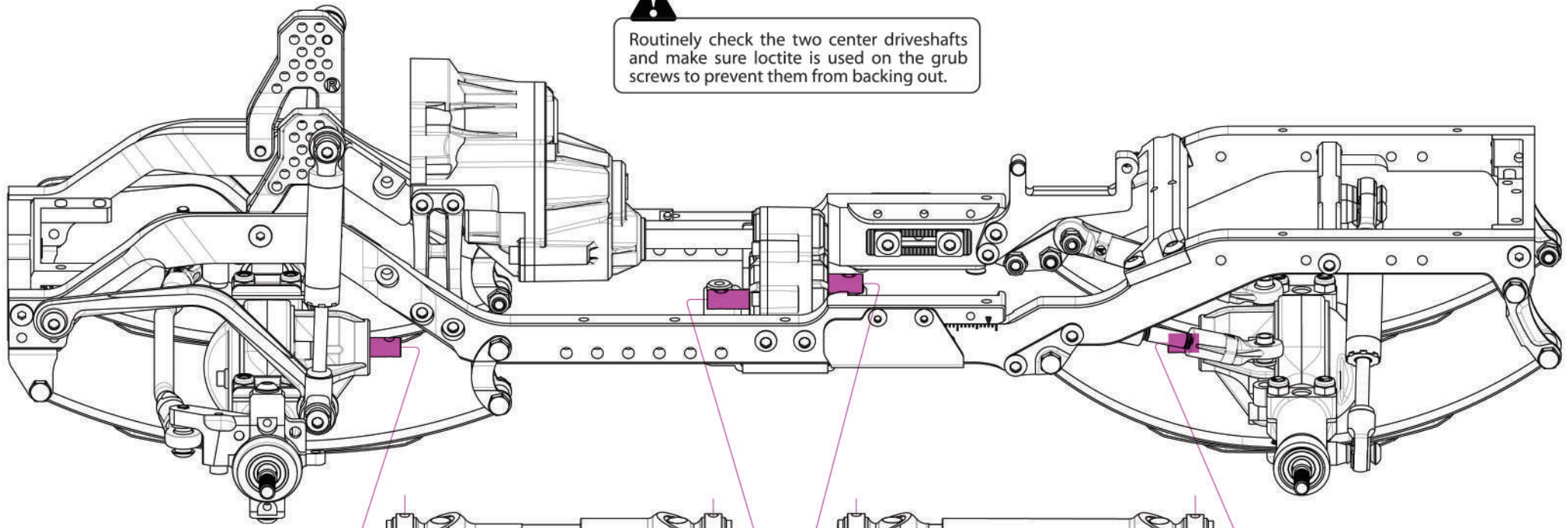

M3/2.2X11 Set Screw X2

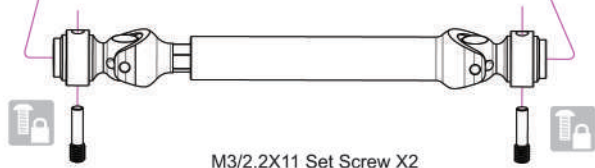

M3/2.2X11 Set Screw X2

# 11 - REAR ANTI-WRAP BAR

## B LEAFS / SHOCKS



3x6x6  
Tapper Spacer x 2  
#BRLC7042



M3 Nut - Nylon x 2  
#BRASNUTM3



M3x22 RS x 2  
#BRASBH3024

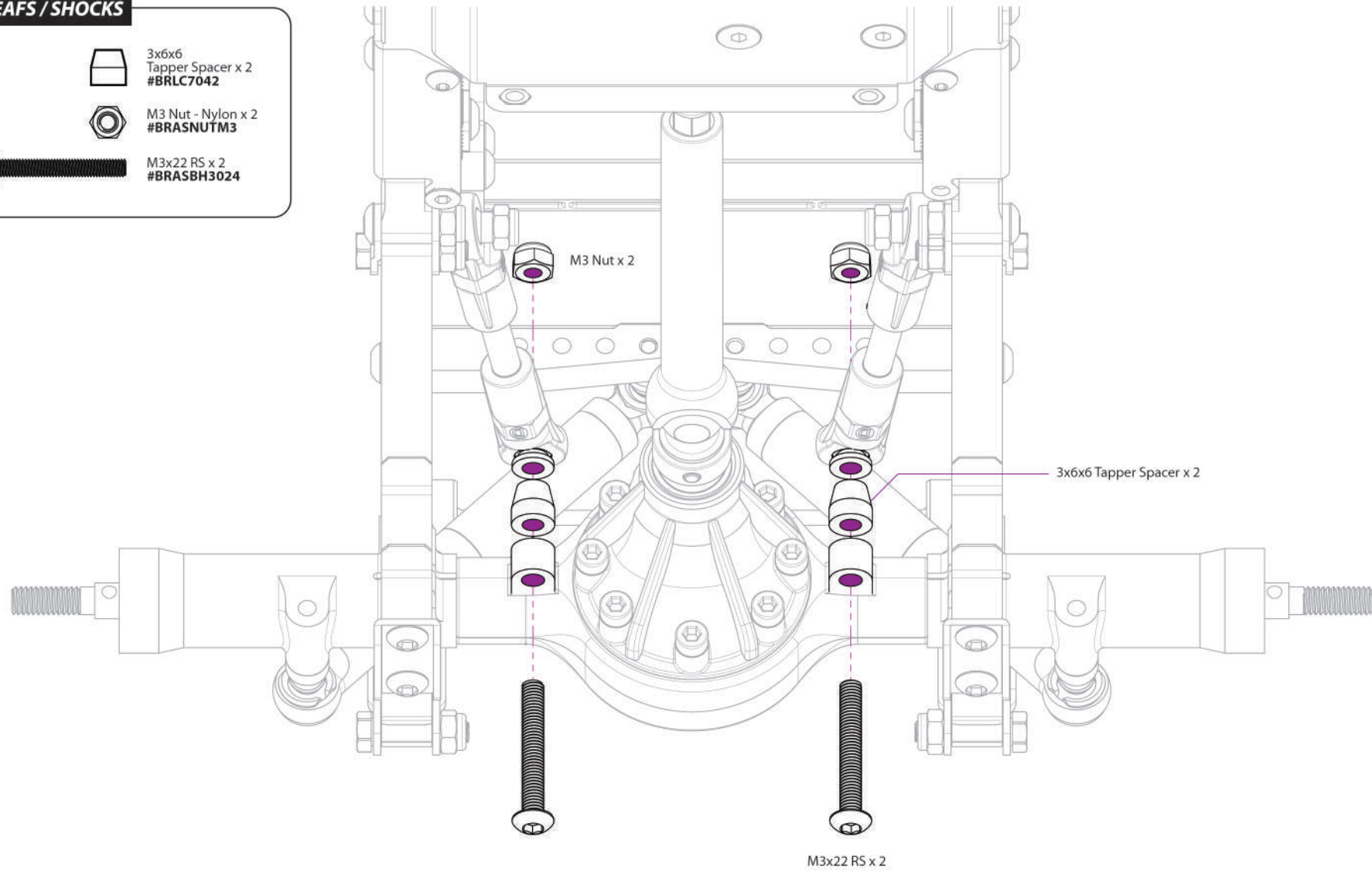



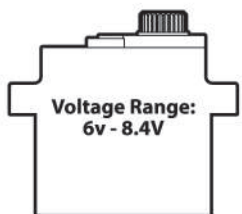
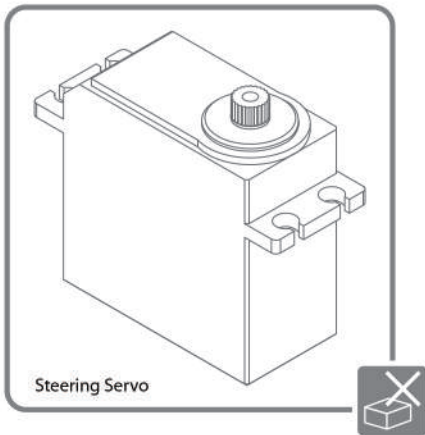

# 12 - SERVOS

Parts Needed:



JX Waterproof HV Mini Servo x 1  
#JX/PDI-HV1151MG

- G SERVOS**
-  M3 Nut - Nylon x 2  
#BRASUTM3
  -  M3x6 RS x 1  
#BRASBH3006
  -  M3x8 RS x 2  
#BRASBH3008
  -  M3x12 RS x 2  
#BRASBH3012

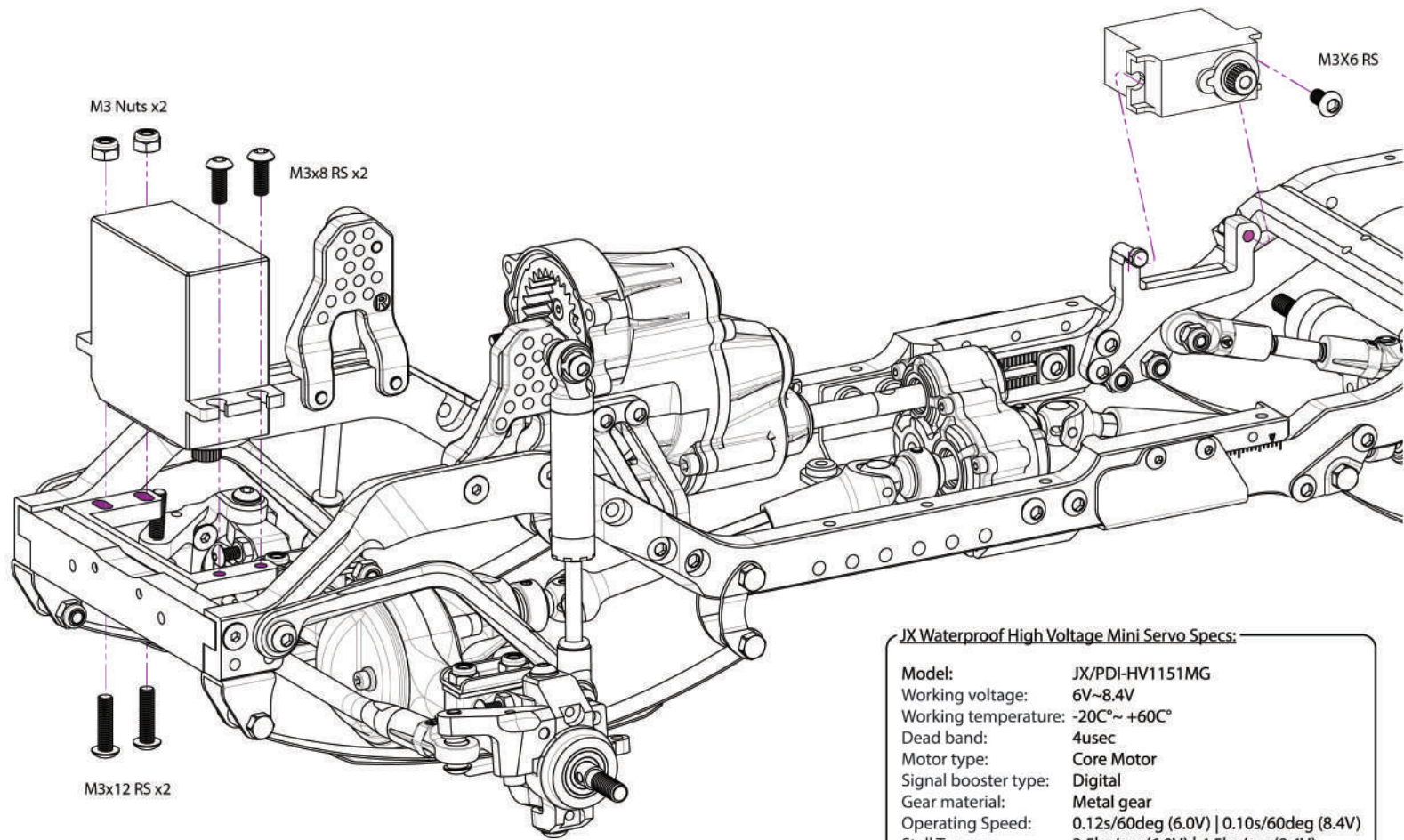

**JX Waterproof High Voltage Mini Servo Specs:**

Model:	JX/PDI-HV1151MG
Working voltage:	6V~8.4V
Working temperature:	-20C~+60C°
Dead band:	4usec
Motor type:	Core Motor
Signal booster type:	Digital
Gear material:	Metal gear
Operating Speed:	0.12s/60deg (6.0V)   0.10s/60deg (8.4V)
Stall Torque:	3.5kg/cm (6.0V)   4.5kg/cm (8.4V)
Idle Current:	150mA (6.0V)   180mA (8.4V)
Load Current:	260mA (6.0V)   340mA (8.4V)
Size:	23.2 x 12.5 x 25.6mm
Weight:	15g
Tooth Count:	25
Wire length:	310mm JR plug
Black:	Negative
Red:	Positive
White:	Signal

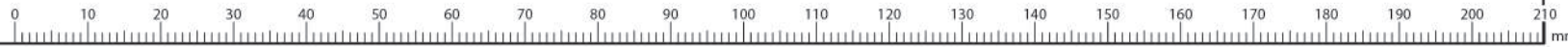

SERVOS

SERVOS





### INSTALLING THE SHIFT ROD & CONFIGURING THE SHIFT SERVO

1. Attach the shift rod to the servo saver first, then connect it to the gearbox as illustrated in the diagram.
2. Temporarily connect the electronics. Choose a channel with a two-position switch and plug the shift servo into that channel.
3. With the servo connected, lower the EPA (End Point Adjustment) on both sides initially. Test the servo's rotation direction: counterclockwise shifts to first gear, and clockwise shifts to second gear (see diagram for reference).
4. Ensure the shift servo is set to the first gear position and the shift rod on the gearbox is fully extended outward. If it's not fully out (it should extend approximately 16mm), rotate the wheels slightly to adjust.
5. Once these steps are complete, secure the servo saver to the shift servo. Then, adjust the EPA settings to fine-tune the shifting, ensuring smooth transitions into both first and second gears.

\* Note: Failure to setup the shift servo properly may cause the shift servo to malfunction or not shift into gear properly.

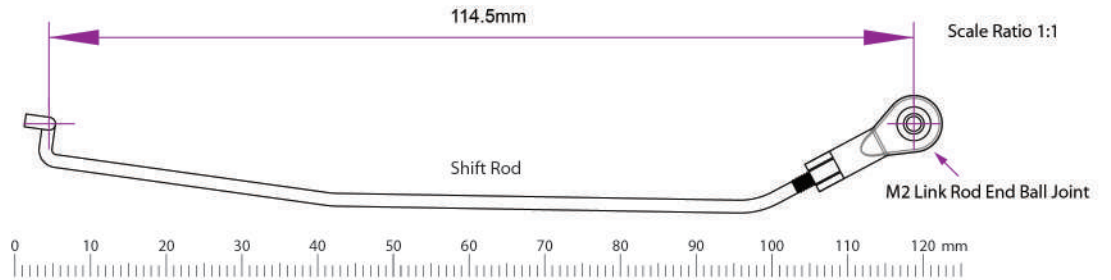
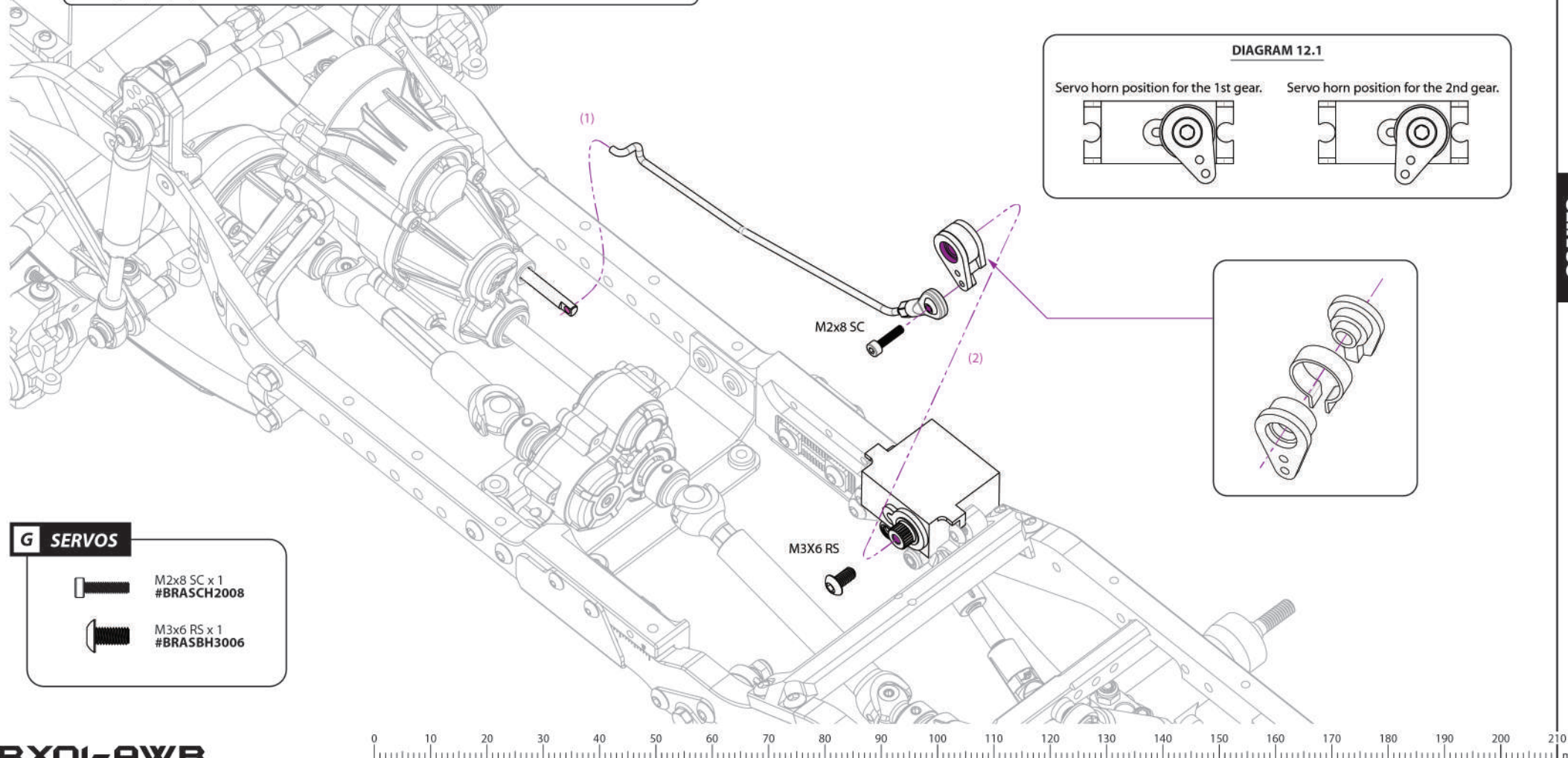
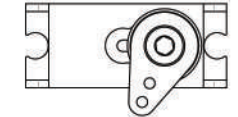
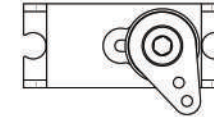

DIAGRAM 12.1

Servo horn position for the 1st gear.      Servo horn position for the 2nd gear.



### G SERVOS

-  M2x8 SC x 1  
#BRASCH2008
-  M3x6 RS x 1  
#BRASBH3006

# 13 - MOTOR

## Parts Needed:

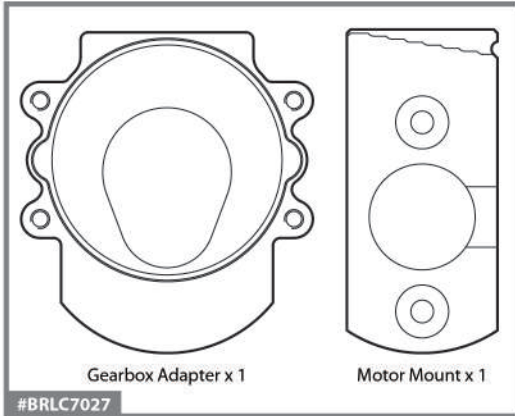
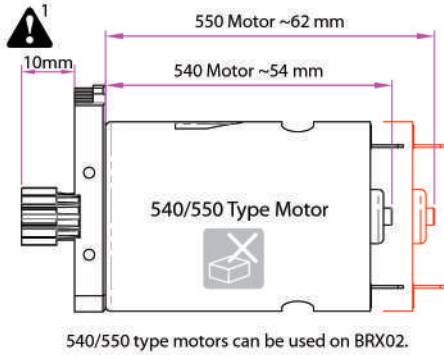

## E GEARBOX / TRANSFER CASE

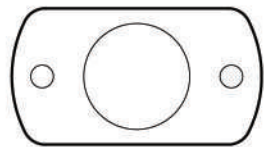

Motor Spacer x 1  
#BRLC7032



M3x8 SC x 2  
#BRASCH3008



M2.5x8 SC x 8  
#BRASCH2508



12T 32P Pinion Gear  
#BRPG3212-3

**!**  
2

Use the corresponding number of the pinion gear tooth (**!**1) on the Motor Mount to get the best gear mesh. Adjust the Motor Mount up and down until both surface indicators (**!**2) are leveled (align at index 12 for the 12T pinion gear supplied as pictured).

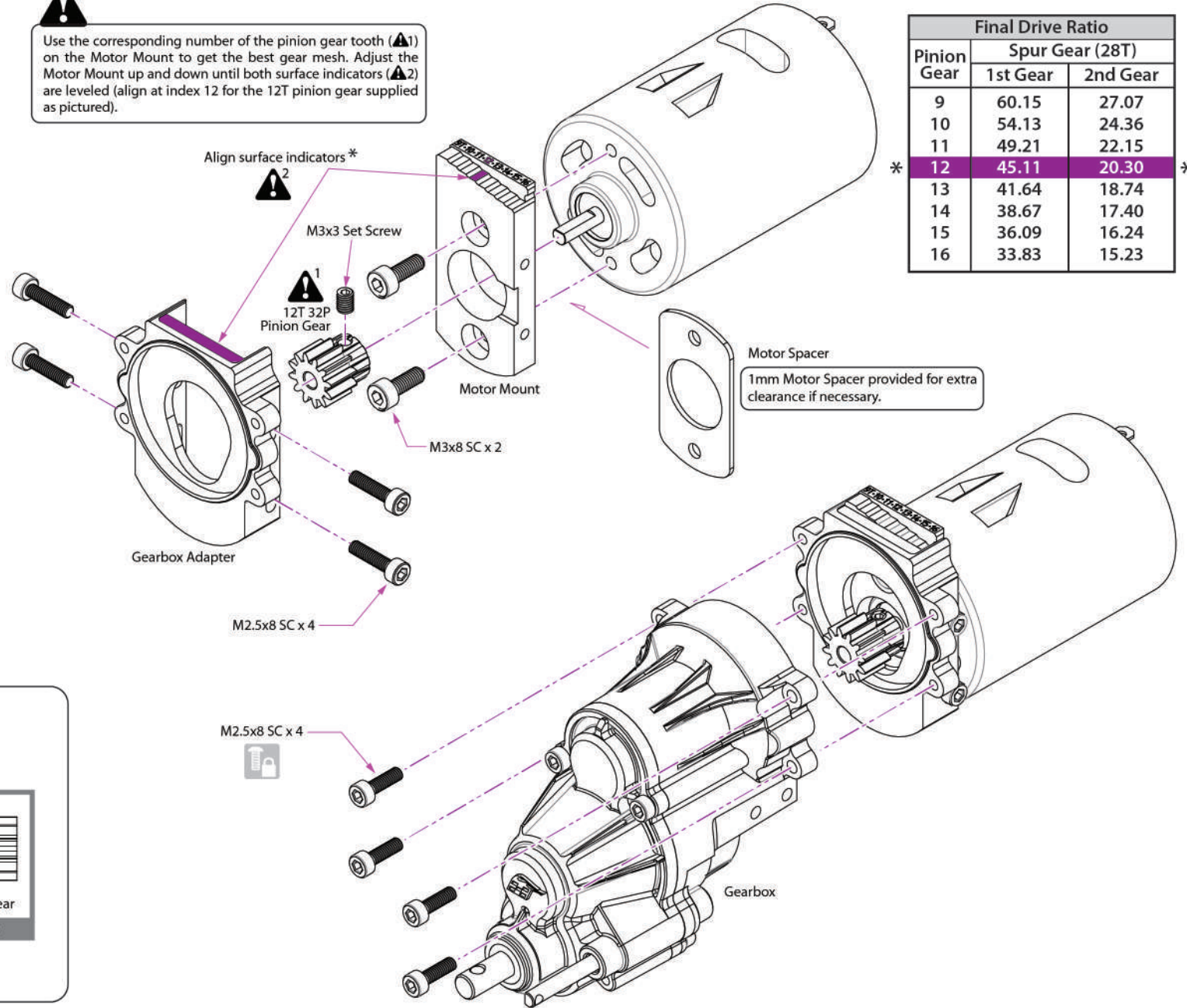

Pinion Gear	Final Drive Ratio	
	Spur Gear (28T)	
	1st Gear	2nd Gear
9	60.15	27.07
10	54.13	24.36
11	49.21	22.15
* 12	45.11	20.30
13	41.64	18.74
14	38.67	17.40
15	36.09	16.24
16	33.83	15.23

# 14 - SKID SLIDER

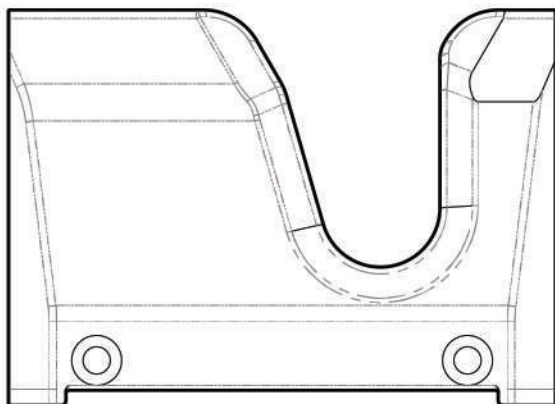

Parts Needed:

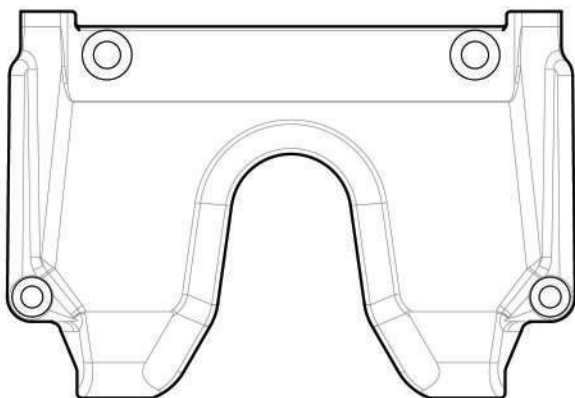

AWB Center Front Slider x 1  
#BRLC70220F

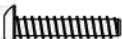

AWB Center Rear Slider x 1  
#BRLC70220R

- A CHASSIS**
-  M2.5x6 CSS x 2  
#BRASFH2506
  -  M3x6 CSS x 4  
#BRASFH3006
  -  M3x14 RS self-tapping x 2

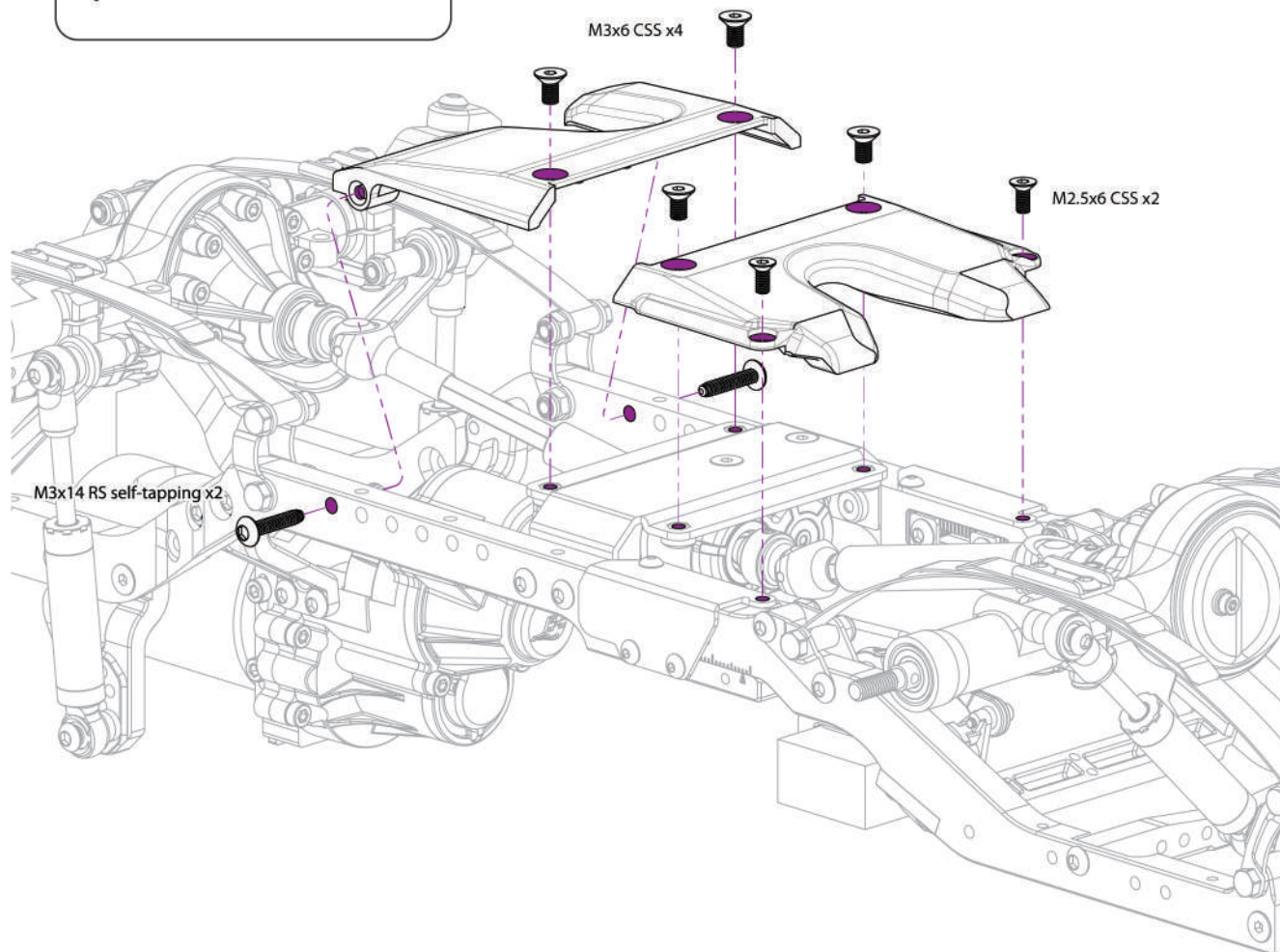

SKID SLIDERS

עלמנה פור

# 15 - RECEIVER BOX & ELECTRONICS INSTALLATION

Parts Needed:

#BRLC70221

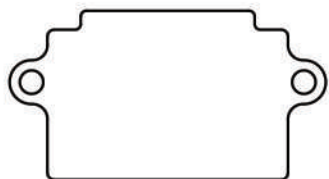

Stainless Steel Sealing Plate x 1



Silicone Port x 1

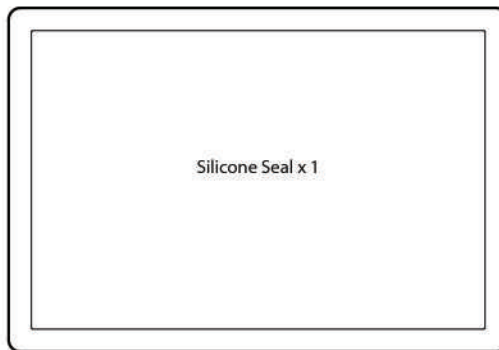

Silicone Seal x 1

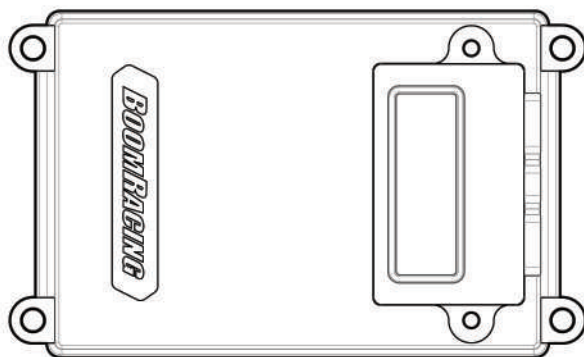

Receiver Box Cover x 1

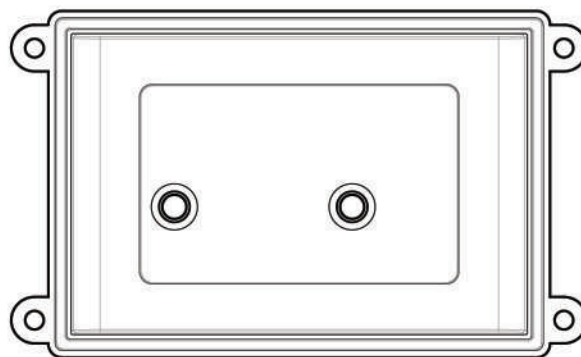

Receiver Box x 1

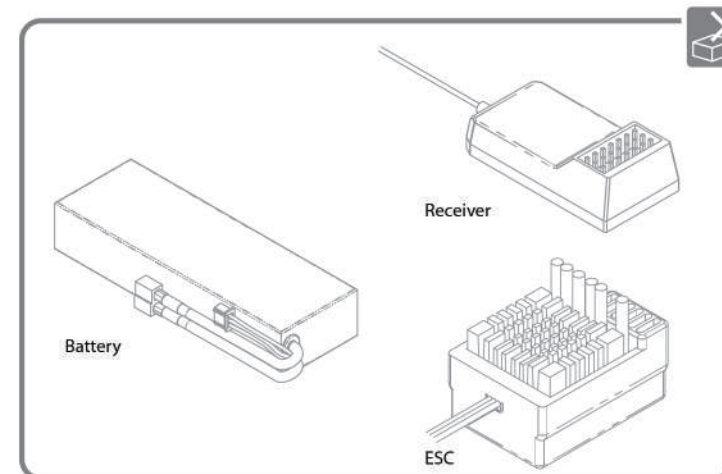

Battery

Receiver

ESC

**F RECEIVER BOX**



M3x8 CSS x 2  
#BRASFH3008



Apply thread lock to all screws.  
(Do not use red thread lock)

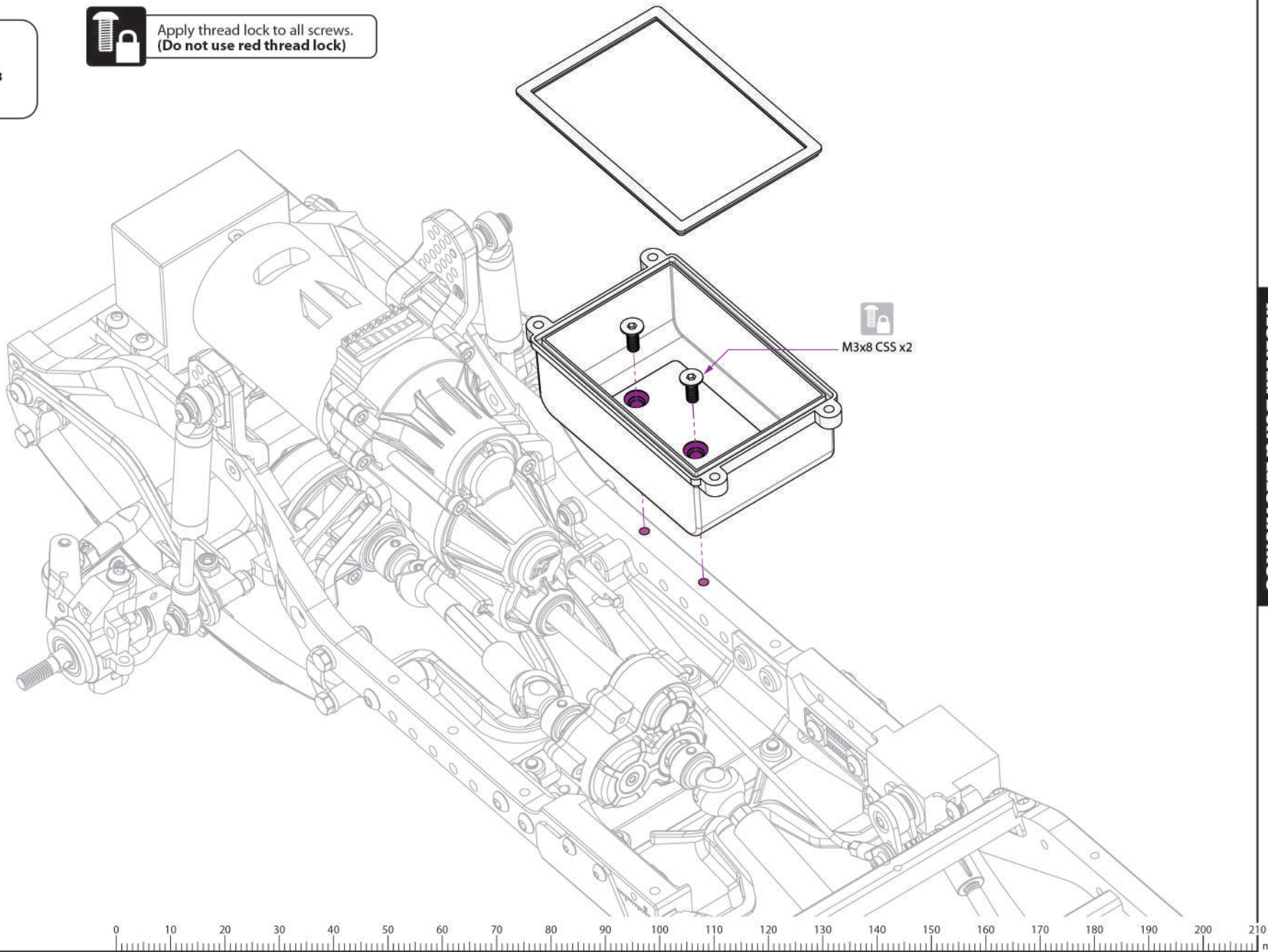

**F RECEIVER BOX**
 M2.5x6 RS x 2  
 #BRASBH2506

 M3x8 RS x 4  
 #BRASBH3008

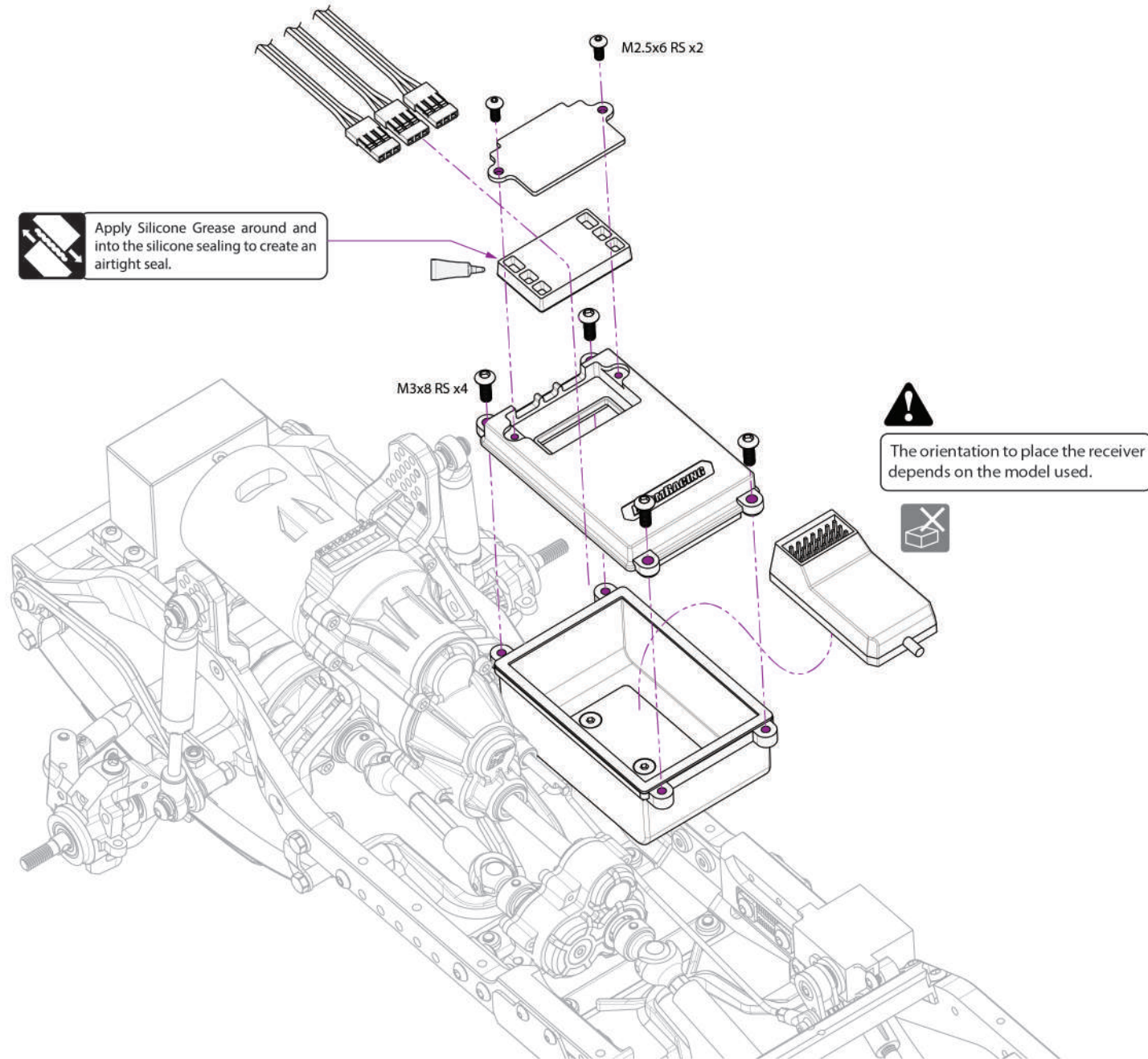
 Apply Silicone Grease around and into the silicone sealing to create an airtight seal.

# 16 - ESC MOUNT

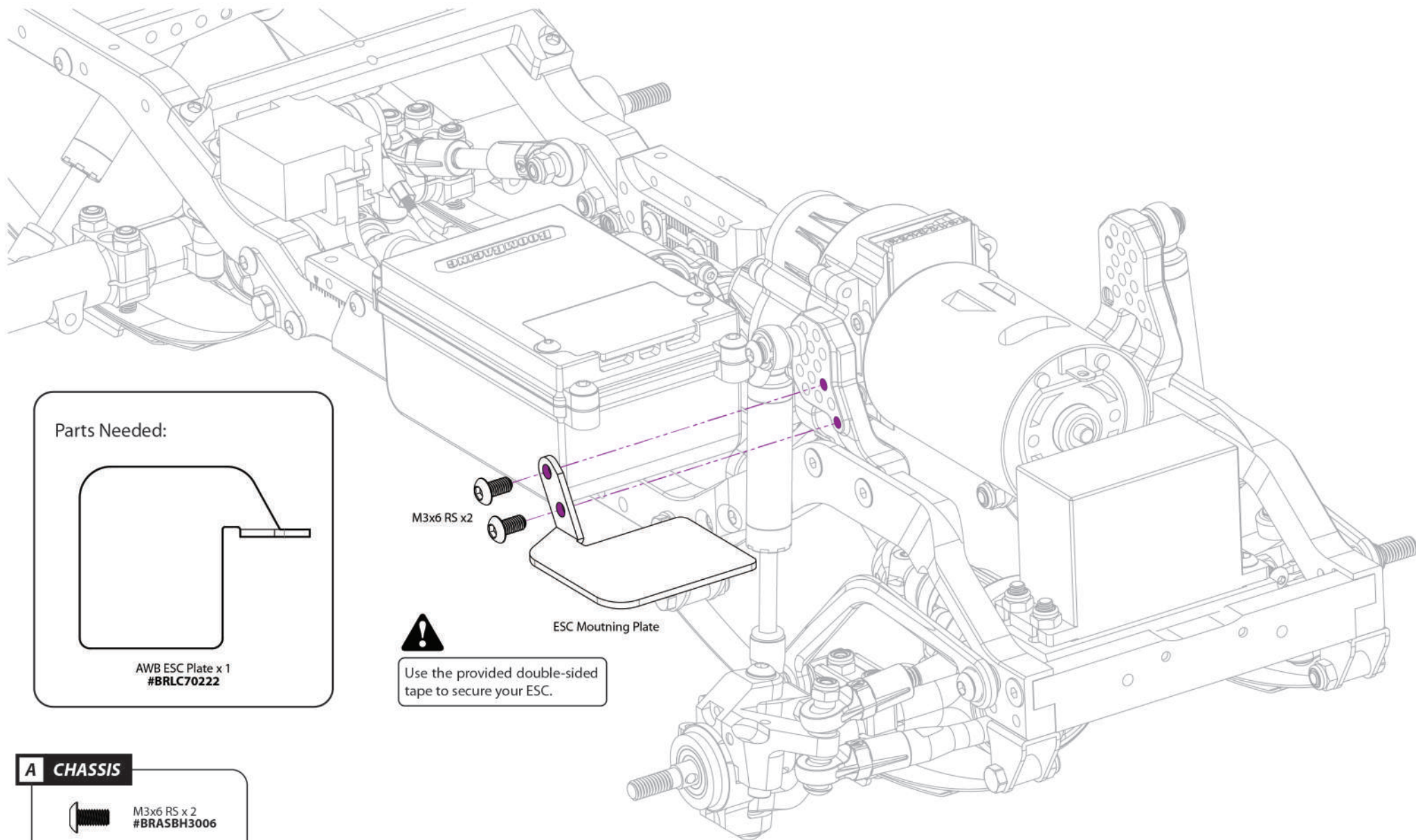

Parts Needed:

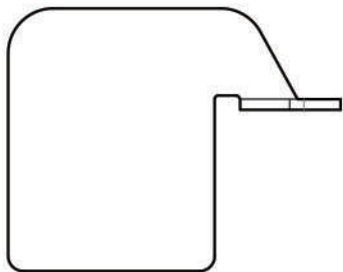

AWB ESC Plate x 1  
#BRLC70222

M3x6 RS x2

ESC Mounting Plate



Use the provided double-sided tape to secure your ESC.

## A CHASSIS



M3x6 RS x 2  
#BRASBH3006

# 17 - WHEELS & TIRES

Parts Needed:

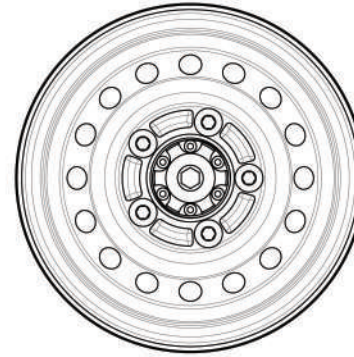

1.55" 16-Hole Classic Steelie Reversible  
 Beadlock Wheels (Front)  
 w/ XT504 Hubs x 2 (Gun Metal)  
**#BRW780955FGM**

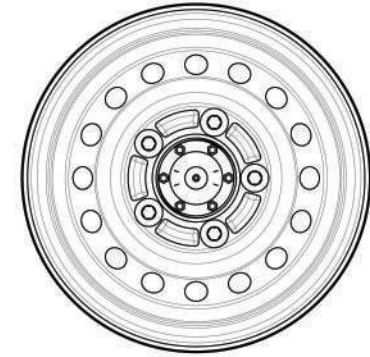

1.55" 16-Hole Classic Steelie Reversible  
 Beadlock Wheels (Rear)  
 w/ XT504 Hubs x 2 (Gun Metal)  
**#BRW780955RGM**

## D WHEELS

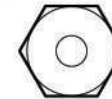

Hex Adaptor x 4  
**#BR113008BK**



M4 Nut - Nyloc x 4  
**#BRASNUTM4**



2x10mm Pin x 4  
**#BRASPIN210**



M3x3 SS x 4  
**#BRASST3003**

(Wheels, tires, and inserts not included in Builder's Kit BR8011)

(Wheels, tires, and inserts not included in Builder's Kit BR8011)

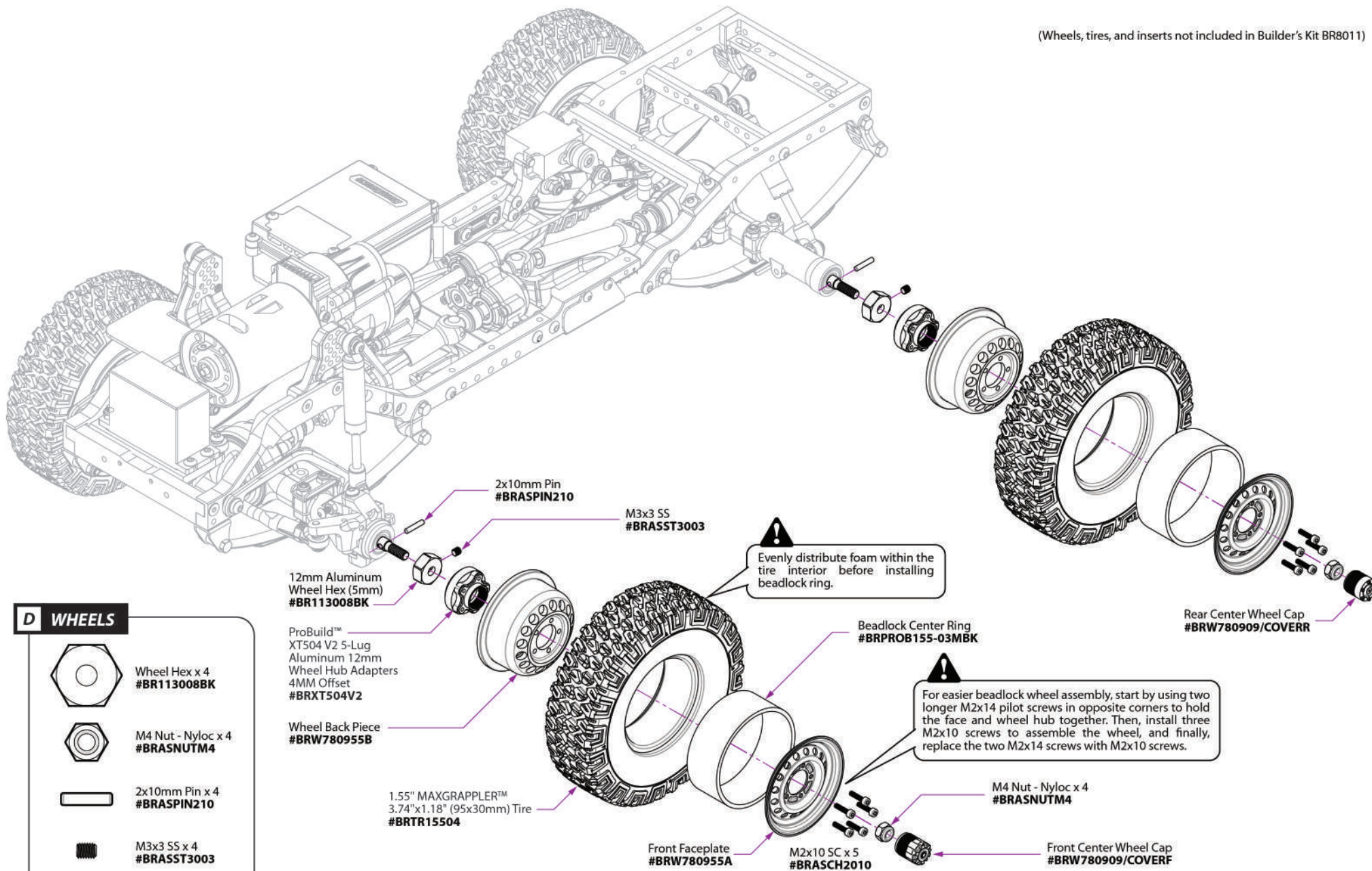

**D WHEELS**

-  Wheel Hex x 4  
#BR113008BK
-  M4 Nut - Nyloc x 4  
#BRASNUTM4
-  2x10mm Pin x 4  
#BRASPIN210
-  M3x3 SS x 4  
#BRASST3003

## PRE-ASSEMBLED AXLE

### Front Diff Cover Release Method In Case Assembly Is Tight.

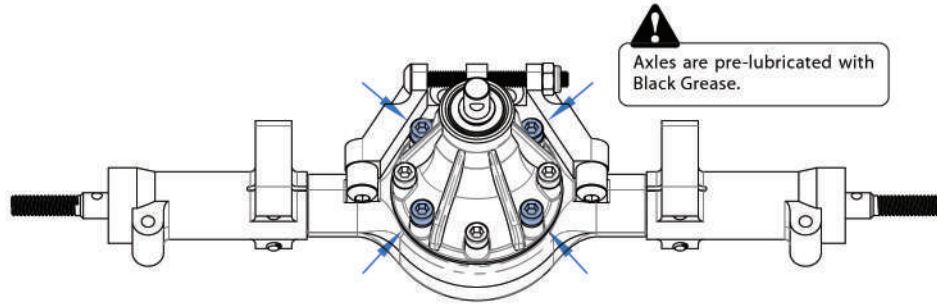

Step 1 - Loosen four M2.5x16mm socket screws indicated making the screw cap 3 mm apart from the case.

Step 2 - Hammer those screw slightly via screwdriver to release the front diff cover.

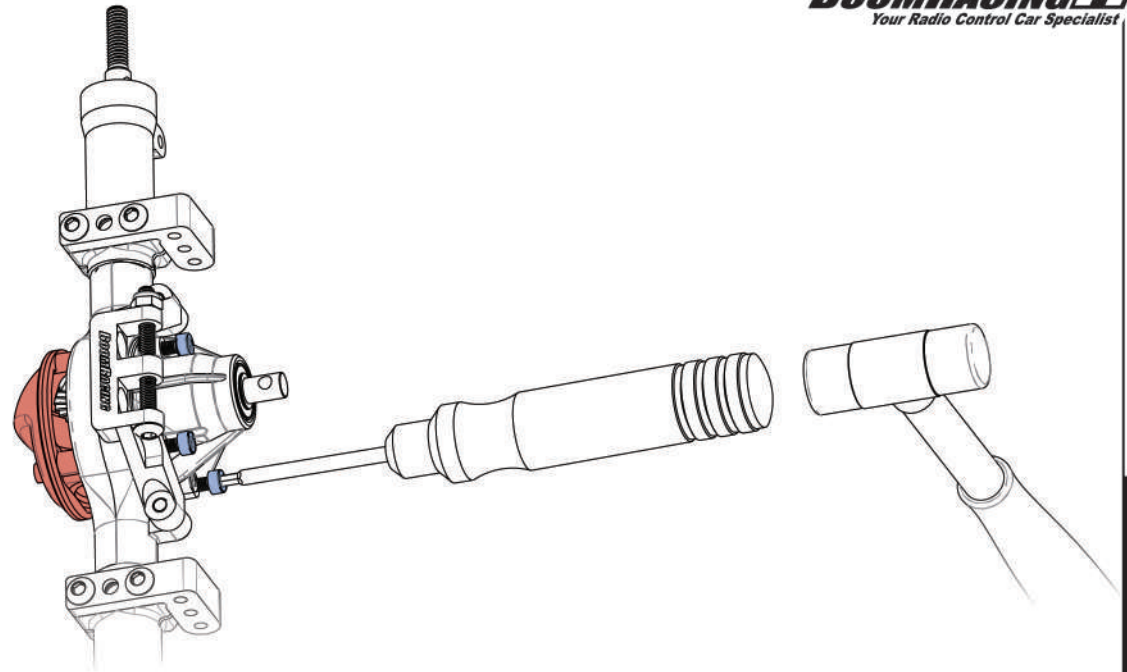

### The Third Member Release Method When Assembly Is Tight.

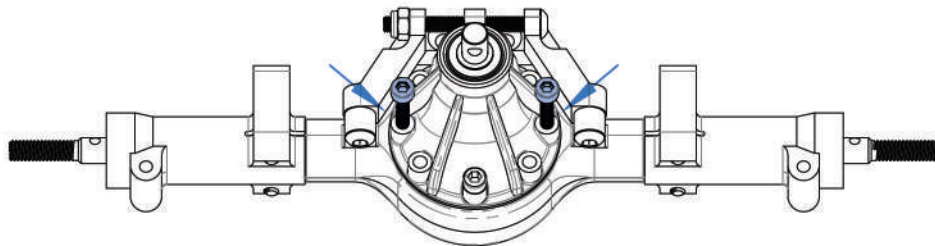

Step 1 - Remove all M2.5x16mm and two M2.5x5mm socket screws

Step 2 - Install two M2.5x16mm socket screws into both left and right screw holes as indicated

Step 3 - Lightly torque the screws until the third member is released

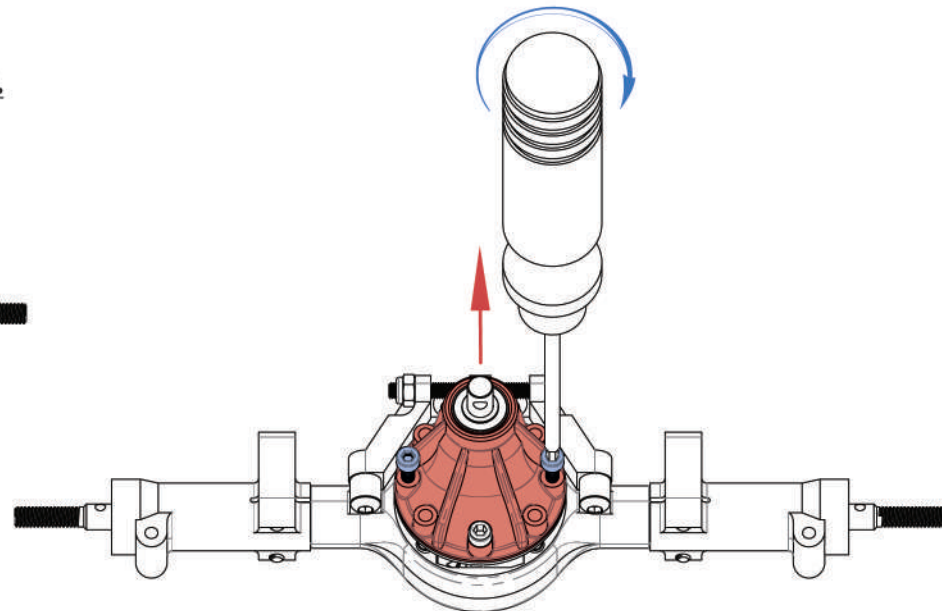

# PRE-ASSEMBLED FRONT AXLE

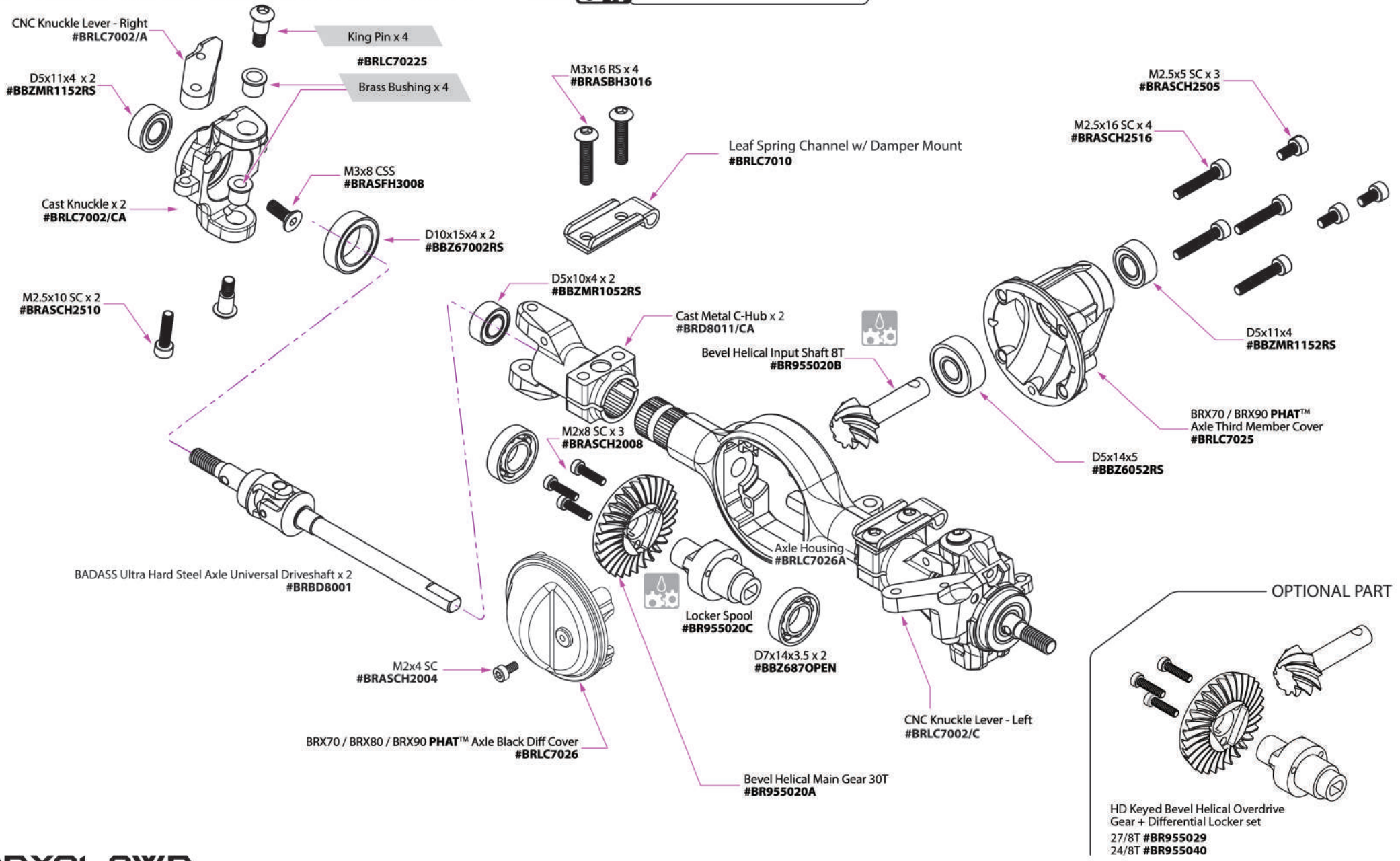

  Apply a generous amount of Black Grease on all movable contact surfaces including gears, spacers, shafts and bearings.



PRE-ASSEMBLED PARTS

PRE-ASSEMBLED PARTS

**PRE-ASSEMBLED REAR AXLE**

  Apply a generous amount of Black Grease on all movable contact surfaces including gears, spacers, shafts and bearings.

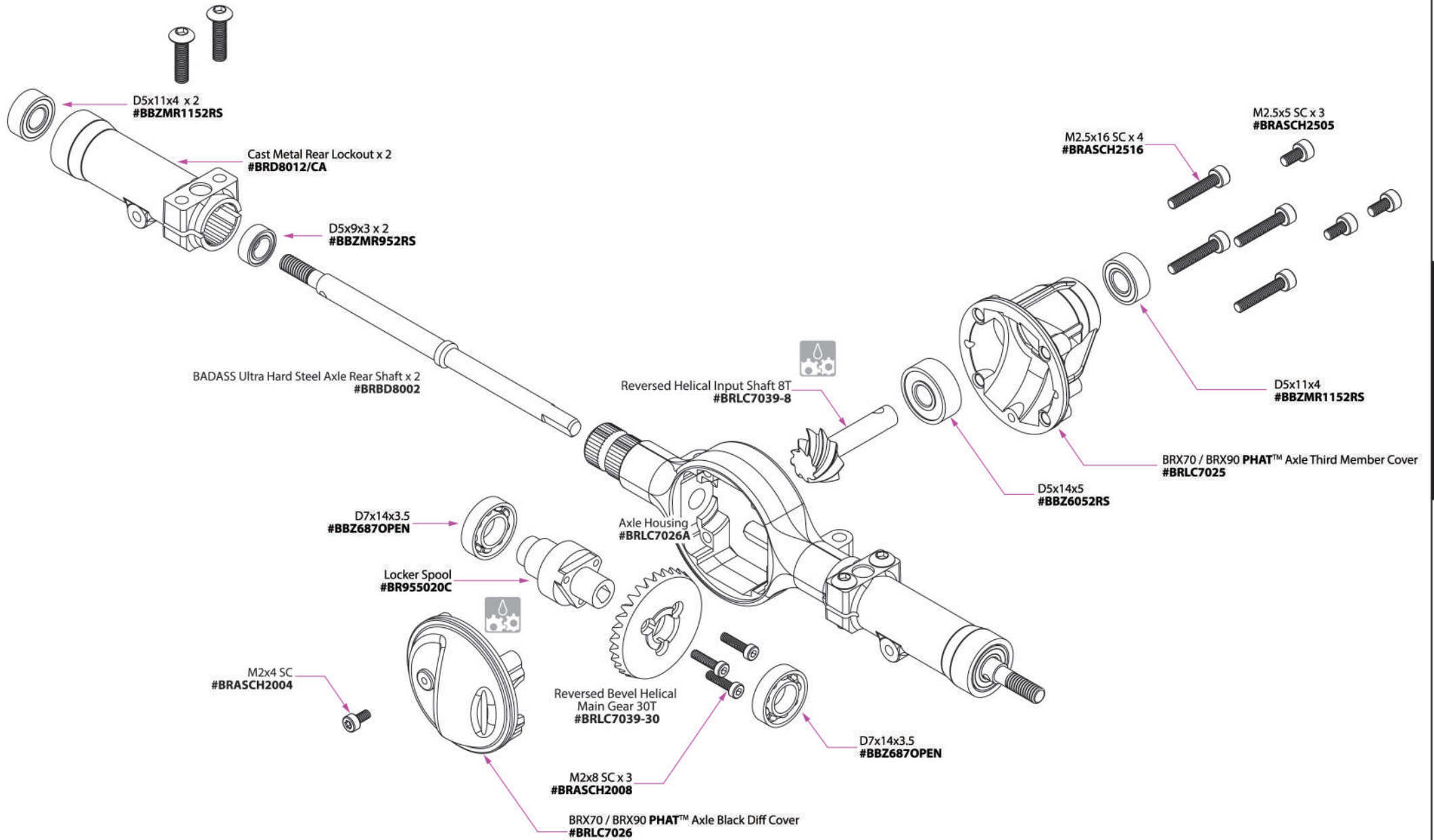

PRE-ASSEMBLED PARTS

PRE-ASSEMBLED PARTS

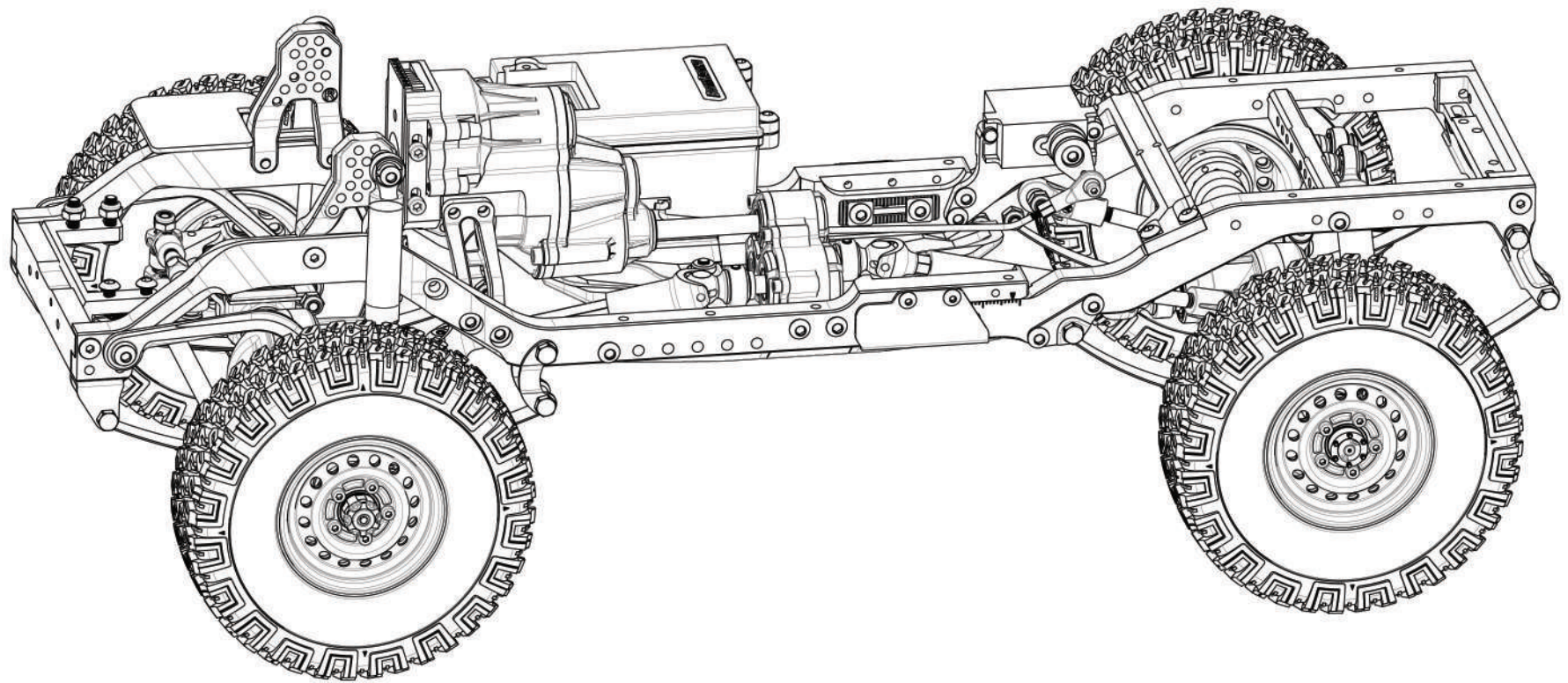

Illustration for reference only.  
(Wheels, tires, and inserts not included in Builder's Kit BR8011)

# PARTS LIST

Part #	Description	Part #	Description
BBZ6052RS	High Performance Rubber Sealed Ball Bearing 5x14x5mm (1)	BRBD8001	BADASS™ Ultra Hard Steel Axle Universal Driveshaft (2pcs) for BRX80 PHAT™ Axle BRD8022
BBZMR1042RS	High Performance Rubber Sealed Ball Bearing 4x10x4mm (1)	BRBD8002	BADASS™ Ultra Hard Steel Axle Rear Shaft (2pcs) for BRX80 PHAT™ Axle BRD8023
BBZMR1052RS	High Performance Rubber Sealed Ball Bearing 5x10x4mm (1)	BRD8011/CA	Cast C-Hub for BRX80 PHAT™ Axle #BRD8022 Black
BBZMR1152RS	D5X11X4 Ball Bearing (7)	BRD8012/CA	Cast Rear Lockout for BRX80 PHAT™ Axle #BRD8023 Black (2)
BBZMR1172RS	High Performance Rubber Sealed Ball Bearing 7x11x3mm (1)	BRD8022A	Stainless Steel Tie Rod (1) for BRX80 PHAT™ Axle
BR113008BK	12mm Standard Aluminum Wheel Hex Adaptors (4)	BRGRS10274-10	BADASS™ Silicone Grease 10g (1)
BR955014BK	Low Profile Servo Horn 25T Black	BRGRS1055-10	BADASS™ Black Graphite Grease 10g (1)
BR955020	Heavy Duty Keyed Bevel Helical Gear 30/8T + Differential Locker Spool Set	BRGRS242	242 Thread Lock 2g (1)
BRASBH2506	M2.5x6mm Round Head 12.9 Grade Nickel Plated Screws (10)	BRKD003-90	KUDU™ Heavy-Duty 80-90mm Steel CVD Center Drive Shaft (1)
BRASBH2514	M2.5x14mm Round Head 12.9 Grade Nickel Plated Screws (10)	BRKD003-94	KUDU™ Heavy-Duty 84-99mm Steel CVD Center Drive Shaft (1)
BRASBH3006	M3.0x6mm Round Head 12.9 Grade Nickel Plated Screws (10)	BRLC7002/A	Aluminum Knuckle Lever (High Clearance) Right for BRX70/BRX80/BRX90 PHAT™ Axle Knuckle (1)
BRASBH3008	M3.0x8mm Round Head 12.9 Grade Nickel Plated Screws (10)	BRLC7002/C	Aluminum Knuckle Lever (High Clearance) Left for BRX70/BRX80/BRX90 PHAT™ Axle Knuckle (1)
BRASBH3010	M3.0x10mm Round Head 12.9 Grade Nickel Plated Screws (10)	BRLC7002/CA	Cast Metal Knuckle for BRX70/BRX80/BRX90 PHAT™ & AR44 Axle (2)
BRASBH3012	M3.0x12mm Round Head 12.9 Grade Nickel Plated Screws (10)	BRLC7010	Steel Leaf Spring Channel w/ Shock Mount for BRX70/BRX80/BRX90 PHAT™ Axle (2)
BRASBH3014/ST	M3 x14mm Round Head Self Tapping Screws (10)	BRLC7014	Middle Crossmember
BRASBH3016	M3.0x16mm Round Head 12.9 Grade Nickel Plated Screws (10)	BRLC7016	Steering Servo Mount
BRASBH3020	M3.0x20mm Round Head 12.9 Grade Nickel Plated Screws (10)	BRLC702011	AWB Chassis Front Rail L/R
BRASBH3022	M3.0x22mm Round Head 12.9 Grade Nickel Plated Screws (10)	BRLC70201-B	Front Output shaft for T-case OD
BRASBH3024	M3.0x24mm Round Head 12.9 Grade Nickel Plated Screws (10)	BRLC70202	AWB Front Crossmember
BRASCH2008	M2x8mm Socket Cap Screw 12.9 Grade Nickel Plated Screws (10)	BRLC70204	AWB Front Leaf Spring Shackles R/L (2)
BRASCH2508	M2.5x8mm Socket Cap Screw 12.9 Grade Nickel Plated Screws (10)	BRLC70205	AWB Rear Leaf Spring Retainer (2)
BRASCH2510	M2.5x10mm Socket Cap Screw 12.9 Grade Nickel Plated Screws (10)	BRLC70206	AWB Rear Crossmember
BRASCH3008	M3x8mm Socket Cap Screw 12.9 Grade Nickel Plated Screws (10)	BRLC70207	AWB Switch Lever
BRASEC30	E-clip 3mm (10)	BRLC70208	AWB Front Anti-Wrap Bar (2)
BRASFH2005	M2.5x5mm Counter Sunk Screw 12.9 Grade Nickel Plated Screws (10)	BRLC70209	Rear Anti-Wrap Bar Link (2)
BRASFH2506	M2.5x6mm Counter Sunk Screw 12.9 Grade Nickel Plated Screws (10)	BRLC70210	Gear Set 20Tx1 29Tx2 for T-case SWD & DIG
BRASFH2508	M2.5x8mm Counter Sunk Screw 12.9 Grade Nickel Plated Screws (10)	BRLC70212	AWB Chassis Rear Rail L/R
BRASFH3006	M3*6mm Counter Sunk Screw 12.9 Grade Nickel Plated Screws (10)	BRLC70214	AWB Chassis Side Bracket L/R
BRASFH3008	M3*8mm Counter Sunk Screw 12.9 Grade Nickel Plated Screws (10)	BRLC70215	AWB Slotted Plate (2)
BRASFH3010	M3*10mm Counter Sunk Screw 12.9 Grade Nickel Plated Screws (10)	BRLC70216	AWB Slotted Washer (4)
BRASNUTM25	Non-Flanged Nylon Lock Nut M2.5 (5)	BRLC70218	AWB Front Offset Shock Tower L/R
BRASNUTM3	Non-Flanged Nylon Lock Nut M3 (5)	BRLC7021A	Front Leaf Spring Set (2)
BRASNUTM4	Non-Flanged Nylon Lock Nut M4 (5)	BRLC70220F	AWB Center Front Slider
BRASPIN208	Pin (Steel) 2x8mm (10)	BRLC70220R	AWB Center Rear Slider
BRASPIN210	Wheel Hex Pin (Steel) 2x10mm (10)	BRLC70221	AWB Receiver Box Set
BRASSPD4705	Spacer D4X7X0.5 (1)	BRLC70222	AWB ESC Plate
BRASSPD5801	Spacer D5X8X0.1 Stainless Steel (10)	BRLC70223R	Mini Servo Mount for AWB
BRASSPD5805	Spacer D5X8X0.5 Stainless Steel (10)	BRLC70224	AWB Front Leaf Spring Retainer (2)
BRASST3003	M3x3 SS Set Screw (4)	BRLC70225	Brass Bushing (4)
BRASST3022/DS	M3 2.2x11 SS Steel Driveshaft Screw Pin (5)	BRLC70226	King Pin (4)
BRASST4016	M4x16 SS Set Screw (10)	BRLC7024	BRX70/BRX80/BRX90 PHAT™ Axle Housing with Black Diff Cover

# PARTS LIST

Part #	Description	Part #	Description
BRLC7027	Aluminum Gearbox Adapter with Motor Mount	BRW750306A	KUDU™ Rod Ends M4 Nylon (Straight) 18.5mm (6)
BRLC7029-12T	Heavy Duty 12T Gear (1)	BRW750307D	KUDU™ M4 Nylon Rod Ends 20.0mm (Upwards) (2)
BRLC7029-15T	Heavy Duty 15T Gear (1)	BRW750310	Stainless Steel End Pivot Balls for KUDU™ Shocks(10)
BRLC7029-20T	Heavy Duty 20T Gear (1)	BRW780909/COVERF	Front Center Wheel Cap For 1.55" / 1.9" Steelie Beadlock Wheels (XT5 Series)
BRLC7030	HD Steel Spur Gear Mount (1)	BRW780909/COVERR	Rear Center Wheel Cap For 1.55" / 1.9" Steelie Beadlock Wheels (XT5 Series)
BRLC7031	Internal Spur Gear 28T 32 Pitch	BRW780955A	1.55" 16-Hole Classic Steelie Beadlock Front Faceplate Gun Metal (2)
BRLC7032	Motor Spacer	BRW780955B	1.55" 16-Hole Classic Steelie Beadlock Back Piece (1)
BRLC7039	30/8T Reverse HD Steel Triangular Keyed Bevel Helical Cut Diff Gear w/ Spool Set	BRW780955FGM	1.55" 16-Hole Classic Steelie Reversible Beadlock Wheels (Front) w/ XT504 Hubs Gun Metal
BRLC7040	3x6x5 mm Tapper Spacer(2)	BRW780955RGM	1.55" 16-Hole Classic Steelie Reversible Beadlock Wheels (Rear) w/ XT504 Hubs (2) Gun Metal
BRLC7041	3x6x3 mm Tapper Spacer(4)	BRX01BBZ	High Performance Full Ball Bearings Set Rubber Sealed (32 Total)
BRLC7042	3x6x6 mm Tapper Spacer(2)	BRX01GBBBZ	High Performance Ball Bearings Set Rubber Sealed For Gearbox (8 Total)
BRLC7044B	Input Shaft	BRB2XBBZ	High Performance Ball Bearings Set Rubber Sealed For B2X Transfer Case
BRLC7044E	BCF2™ Assembled 2-Speed Transmission Gear Set	BRX020020LF	Center Skid Plate
BRLC7045B	Ultra Hard Steel Shifter	BRX020029	BCF2™ Aluminum Gearbox Housing
BRLC7045C	Stainless Steel Shift Rod	BRX020029A	Bearing Holder
BRLC7049	2 Speed Servo Horn Set	BRX020030	Brass Washer (4)
BRLC7050	Stainless Steel Drag Link & Panhard Link Set	BRX020110	Side Gearbox Mount L&R
BRLC7059	Extension Cable (2)	BRX020111	B2X™ Transfer Case Housing (OD Ready)
BRLC7064A	Rear Leaf Spring Set (2)	BRX020115F	BRX80 Complete Front PHAT™ Axle Leaf Spring Ver (1)
BRLC7064B	Center Crossmember for Leaf Spring	BRX020115R	BRX80 Complete Rear PHAT™ Axle Leaf Spring Ver (1)
BRLC7064D	Rear Leaf Spring Shackles (2)	BRXT504V2	ProBuild™ XT504 V2 5-Lug Aluminum 12mm Wheel Hub Adapters 4MM Offset (2)
BRLC7064E	M3x14 Bolt (12)	JX/PDI-HV1151MG	JX Waterproof HV Mini Servo 8.4V
BRLC7064G	Leaf Spring Channel (4)		
BRLC7207-P	Guiding Shaft (1)		
BRLC7208	Rear Output Shaft for T-case OD & SWD		
BRLC7209	High Efficiency Output Shaft		
BRPG3212-3	32P 12T / 3.175mm Steel Pinion Gear		
BRPHAT22BBZ	Full Ball Bearings Set for Front PHAT™ 70/80/90 Axle		
BRPHAT23BBZ	Full Ball Bearings Set for Rear PHAT™ 70/80/90 Axle		
BRPROB155-03MBK	ProBuild™ 1.55" Aluminum Beadlock Center Ring (1)		
BRQ90351	M2 Link Rod End Ball Joint (1)		
BRSR0070	KUDU™ 70mm Scale Shock Absorbers (4)		
BRSRJR	Joint Retainer (8)		
BRSR0030	BADASS™ 30WT Shock Oil 15ml		
BRSORD6-15	D6x1.5 O-Ring (10)		
BRT10028	Tool Set		
BRT10037	Cable Wiring Retainer		
BRT10053	Pivot Ball Tool		
BRTR15504	1.55" MAXGRAPPLER Scale RC Tire Gekko (Black) Compound 3.74"x1.18" (95x30mm) Open Cell Foams (4)		
BRW750300	BADASS™ Heavy Duty Rust-Resistant Stainless Steel Flanged Pivot Ball (8)		

## PARTS LIST (Optional Accessories)

Part #	Description	Part #	Description
<b>Chassis Parts</b>		<b>Pinion Gear</b>	
BRD9024	Brass Rear Knuckle Base Weights for BRX80 / BRX90 PHAT™ Axle (2)	BRPG3209-3	32P 9T / 3.175mm Steel Pinion Gear (1)
BRLC70101-DIG	DIG Transfer Case Kit	BRPG3210-3	32P 10T / 3.175mm Steel Pinion Gear (1)
BRLC70213	AWB Chassis Rear Rail XL (287-307mm) R/L	BRPG3211-3	32P 11T / 3.175mm Steel Pinion Gear (1)
BRLC70219F	Tubular Alum Front Bumper	BRPG3213-3	32P 13T / 3.175mm Steel Pinion Gear (1)
BRLC70219R	Tubular Alum Rear Bumper	BRPG3214-3	32P 14T / 3.175mm Steel Pinion Gear (1)
BRLC70223A	Wire Cable Retainer for BRX01 AWB	BRPG3215-3	32P 15T / 3.175mm Steel Pinion Gear (1)
BRLC70223L	Mini Servo Mount for BRX01 AWB	BRPG3216-3	32P 16T / 3.175mm Steel Pinion Gear (1)
BRLC70301-SWD	SWD (Selective RWD/4WD) Transfer Case Kit	BRPG32COMBO1-3	32P Steel Pinion Gear Combo 9T-12T (4)
BRLC7086F	Front Skid Plate for BRX70/BRX80/BRX90 PHAT™ Axle	BRPG32COMBO2-3	32P Steel Pinion Gear Combo 13T-16T (4)
BRLC7086R	Rear Skid Plate for BRX70/BRX80/BRX90 PHAT™ Axle		
BRLC7088	XT Diff Cover for BRX70/BRX80/BRX90 PHAT™ Axle	<b>Shock Oil</b>	
BRLC7089	Brass Front Knuckle Base Weights for BRX70/BRX80/BRX90 PHAT™ & AR44 Axle (2)	BRSHK010	<b>BADASS™</b> Silicone Shock Oil 10wt 60ml
BRLC7092	Brass Small Weight Blocks 4g for BRX70/BRX80/BRX90 PHAT™ Axle Knuckle Weight Base (6)	BRSHK015	<b>BADASS™</b> Silicone Shock Oil 15wt 60ml
BRLC7200	Servo Winch Mount Kit	BRSHK020	<b>BADASS™</b> Silicone Shock Oil 20wt 60ml
<b>Gears</b>		BRSHK025	<b>BADASS™</b> Silicone Shock Oil 25wt 60ml
BR955029	Overdrive HD Steel Keyed Bevel Helical Gear 27/8T + Diff Locker Spool Set	BRSHK030	<b>BADASS™</b> Silicone Shock Oil 30wt 60ml
BR955040	Overdrive HD Steel Keyed Bevel Helical Gear 24/8T + Diff Locker Spool Set	BRSHK035	<b>BADASS™</b> Silicone Shock Oil 35wt 60ml
BRLC70201-GEAR	Transfer Case Overdrive HD Steel Gear Set	BRSHK040	<b>BADASS™</b> Silicone Shock Oil 40wt 60ml
<b>Wheel Cap</b>		BRSHK045	<b>BADASS™</b> Silicone Shock Oil 45wt 60ml
BRW780921GD	Scale 4WD Center Locking Hub Cap (2) Gold (XT5 Series)	BRSHK050	<b>BADASS™</b> Silicone Shock Oil 50wt 60ml
BRW780921R	Scale 4WD Center Locking Hub Cap (2) Red (XT5 Series)	BRSHK055	<b>BADASS™</b> Silicone Shock Oil 55wt 60ml
BRW780923	S100 Scale Center Wheel Hub Cap (2) Black (XT5 Series)	BRSHK060	<b>BADASS™</b> Silicone Shock Oil 60wt 60ml
BRW780923PL	S100 Scale Center Wheel Hub Cap (2) Platinum (XT5 Series)	BRSHK065	<b>BADASS™</b> Silicone Shock Oil 65wt 60ml
BRW780923S	S100 Scale Center Wheel Hub Cap (2) Silver (XT5 Series)	BRSHK070	<b>BADASS™</b> Silicone Shock Oil 70wt 60ml
BRW780925BK	Spectre Scale Center Wheel Hub Cap (2) (XT5 Series) Black	BRSHK075	<b>BADASS™</b> Silicone Shock Oil 75wt 60ml
BRW780925S	Spectre Scale Center Wheel Hub Cap (2) (XT5 Series) Silver	BRSHK080	<b>BADASS™</b> Silicone Shock Oil 80wt 60ml
BRW780944	Retro Nylon Center Wheel Cap (4) (XT5 Series) w/ Tool		
BRW780947	Dome Center Cap (2) Chrome (XT5 Series)		
<b>Wheel Hub</b>			
BRXT502PIN	XT502PIN 5-Lug Metal Wheel Pin Hub Adapters +2MM Positive Offset (2)		
BRXT500V2	ProBuild™ XT500 V2 5-Lug Aluminum Wheel Pin Hub Adapters 0MM Offset Version 2 (2) Black		
BRXT508V2	ProBuild™ XT508 V2 5-Lug Aluminum 12mm Wheel Hub Adapters 8MM Offset Version 2 (2) Black		
BRXT512	XT512 5-Lug Aluminum 12mm Wheel Hub Adapters 12mm Offset (2)		

If you have questions, call Boom Racing at:  
 Email Boom Racing at [sales@boomracing.com](mailto:sales@boomracing.com)

[WWW.ENJOYBEINGABADASS.COM](http://WWW.ENJOYBEINGABADASS.COM)

**Adam Sajdak (Germany)**

*The BRX01 AWB is a very successful chassis design that works great off-road! At the same time, thanks to the adjustable wheelbase (AWB), it gives us unlimited possibilities in the future, allowing us to adapt the frame to individual projects. It looks like a great multiplatform that will work in any project.*



**Jeremy Kilburn (United States)**

*Another unmatched build experience from Boom Racing! The quality and thoughtfulness of the AWB kit presents unlimited possibilities with builders, competitors and newcomers in mind.*

**Shawn Roche (United States)**

*I have tested all the BRX trucks and I was excited to get involved with the AWB because it is the chassis the industry has needed for a very long time. Based on the tried a true BRX01 drivetrain it is reliable and it out performs any stock leaf truck I have ever run, this is the perfect chassis for a builder or anyone looking for something different and still want insane performance. Excellent job Boom Racing.*



**Andreas Hahn, Stefan Dölderer (Austria)**

*Thank you for the opportunity to test this model in detail. First of all, the quality is, as always, very high and building the AWB model is fun. Thanks to the adjustable chassis, you will have many options for driving different bodies in the future. The quality of the adjustment mechanism is very good. The rest is tried and tested BRX01 technology which, as everyone knows, is perfect.*

**Matthew Maynard (United States)**

*My journey with Boom Racing began with the pre-order of the BRX02 carbon fiber chassis kit. From the moment I held it, I knew this was an amazing company. Over the years, as I built more trucks, my trust in their quality and professionalism only grew, both in their rigs and customer service. Now, I have the honor of standing in a Boom tent, talking tiny trucks, and helping bring exciting new kits to the RC market. Whether at events or online, I'm proud to be part of this incredible community. Congrats - if you're reading this, you're now part of the Boom family. Welcome, and enjoy committing badassery!*



**Peter Gray (United Kingdom)**

*Building and then running the BRX01 AWB has been an eye opener. It's made me realise why I love this aspect of the hobby so much. A photorealistic body combined with a chassis, transmission and tyre choice that punches well above its wheelbase and wheel size. Add to that the game changing adjustability of the wheelbase via the AWB Chassis and you have a rig that I'm convinced will inspire many a custom build globally... (hell, I'm already planning something myself!)*

**Darius Cybula (Germany)**

*Chassis of new possibilities. The ability to adjust the wheelbase to individual needs gives freedom of choice of bodywork, and the ease with which it can be done even encourages it. All this combined with proven solutions, already known in the BRX01 chassis. I am convinced that it will soon become the most frequently purchased chassis among hobbyists of both scale and performance cars.*





**BOOM RACING**   
*Your Radio Control Car Specialist*

**BRX01**

**AWB**

**ADJUSTABLE WHEELBASE 1/10  
4WD RADIO CONTROL CHASSIS KIT**

[WWW.ENJOYBEINGABADASS.COM](http://WWW.ENJOYBEINGABADASS.COM)