

BOOMRACING 



LAND ROVER SERIES II

109

Hardtop

1/10 HARD BODY KIT 334MM



Congratulations!

Back in 1958, the Series II 109 Hardtop rolled onto the scene, ready to tackle anything from snowy mountain trails to dusty desert paths. Farmers, adventurers, and explorers all fell for its tough, no-nonsense vibe and practical enclosed design.

Approved by Land Rover, this Series II 109 Hardtop model brings back the golden days of off-road fun. It's got that classic rugged look and timeless charm that turned Land Rover into a legend. Whether you're showing it off as a shelf-only scale model or hitting the backcountry trails, this beauty captures the rugged spirit and timeless vibe of one of the world's most iconic off-road vehicles.

This body kit comes with some cool new features: a working rear top door with metal hinges and a legit locking system, roof sides with swappable clear windows or solid panels (you get both!), and a double-skinned tropical roof that's true to the original, keeping things nice and cool in scorching weather.

Congrats on snagging your Boom Racing Land Rover body kit! Here's to sparking your creativity and kicking off epic adventures, on the trail and beyond.

Jason Patrick Tsang
Boom Racing Founder and Director





Apply Double Sided Tape



Pay Attention



Apply Glue



Drill Hole



Apply Model Filler

Tools Included

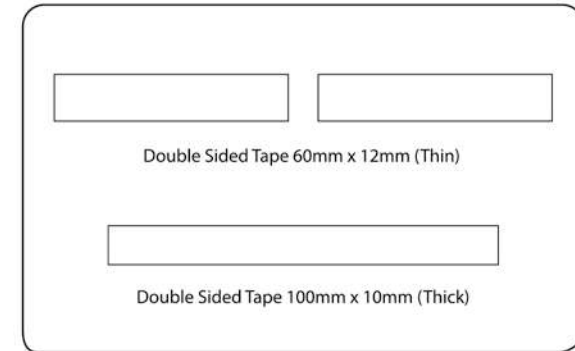
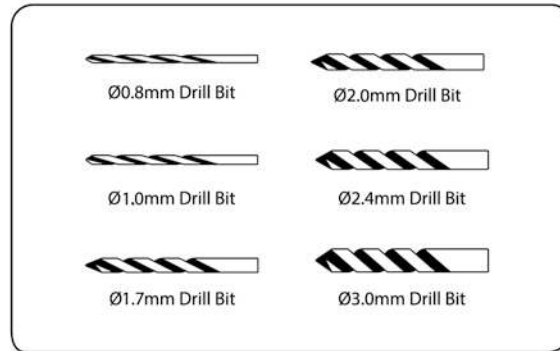
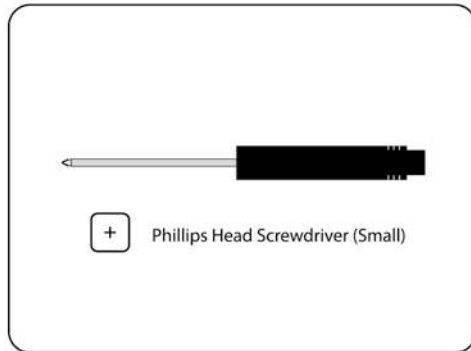

Tools Required

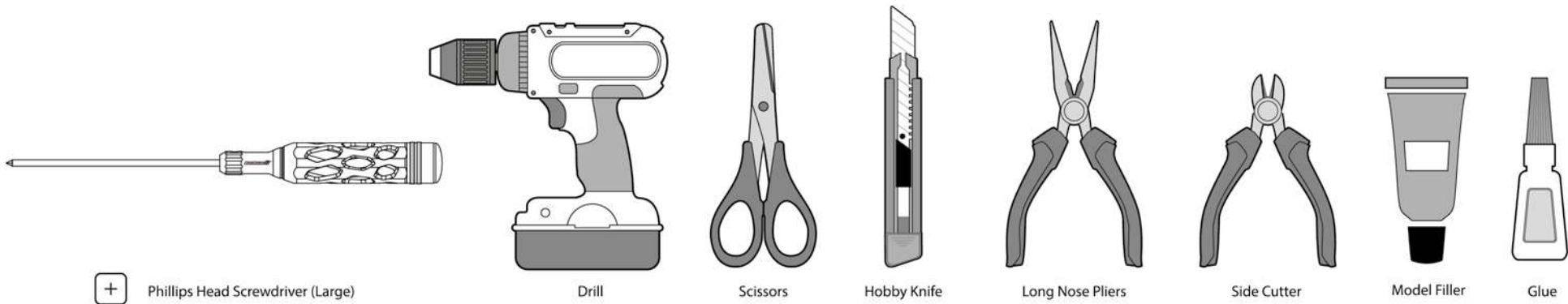



All screw indicators in this manual are 1:1 size (extra screws included).

- | | |
|--|---|
| ST1x4 Phillips Head Self-Tapping Screw (40)
ST1x4 RS | ST2.6x6 Phillips Head Self-Tapping Screw (2)
ST2.6x6 RS |
| ST1x6 Phillips Head Self-Tapping Screw (4)
ST1x6 RS | ST2.6x10 Phillips Head Self-Tapping Screw (2)
ST2.6x10 RS |
| ST1.2x3 Phillips Head Self-Tapping Screw (2)
ST1.2x3 RS | ST1.5x4 Counter Sunk Phillips Head Self-Tapping Screw (4)
ST1.5x4 CSS |
| T1.2x4 Phillips Head Self-Tapping Screw (16)
ST1.2x4 RS | ST2x8 Counter Sunk Phillips Head Self-Tapping Screw (10)
ST2x8 CSS |
| ST1.2x8 Phillips Head Self-Tapping Screw (2)
ST1.2x8 RS | ST3x6 Counter Sunk Phillips Head Self-Tapping Screw (2)
ST3x6 CSS |
| ST1.5x4 Phillips Head Self-Tapping Screw (6)
ST1.5x4 RS | M1.2x3 Phillips Head Screw (2)
M1.2x3 RS |
| ST1.5x5 Phillips Head Self-Tapping Screw (24)
ST1.5x5 RS | M1.5x4 Phillips Head Screw (1)
M1.5x4 RS |
| ST2x5RS Phillips Head Self-Tapping Screw (8)
ST2x5 RS | M2x8 Counter Sunk Phillips Head Screw (4)
M2x8 CSS |
| ST2x6RS Phillips Head Self-Tapping Screw (18)
ST2x6 RS | D3x4 Spring Plunger(4) |
| ST2x8 Phillips Head Self-Tapping Screw (14)
ST2x8 RS | Magnet (2)
OST8x3 |
| | Pin (4) |

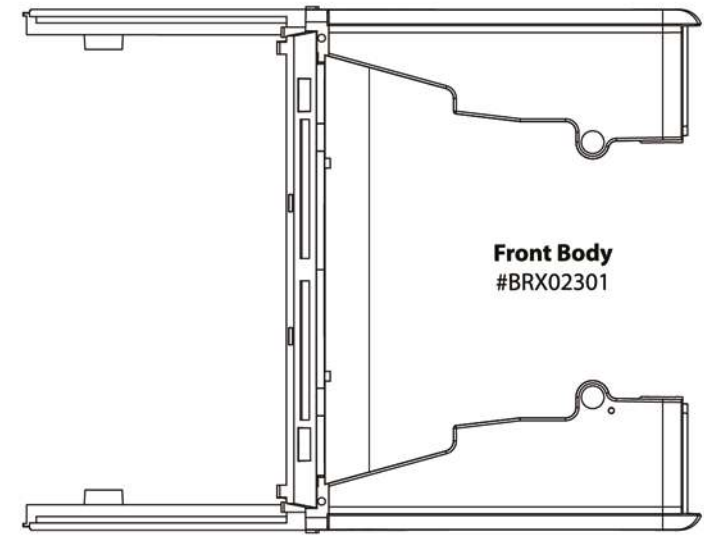

Front Body
#BRX02301

Screw Set for Series II 109 Body
#BRX02412

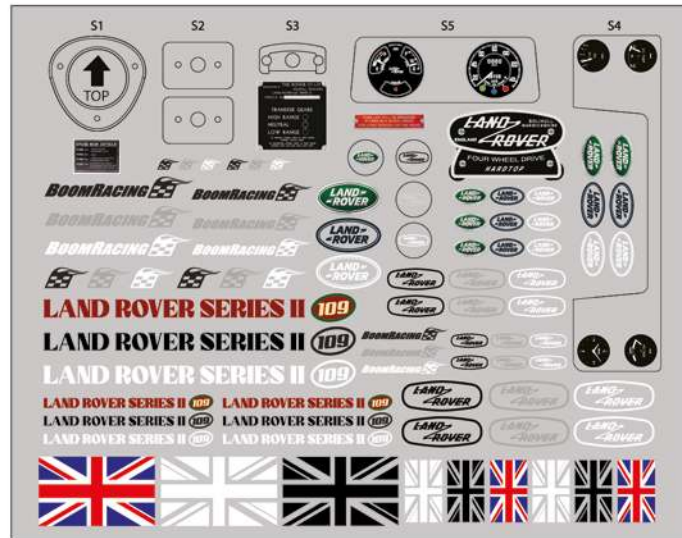

Decal Sticker Series II Hardtop
#BRX02411

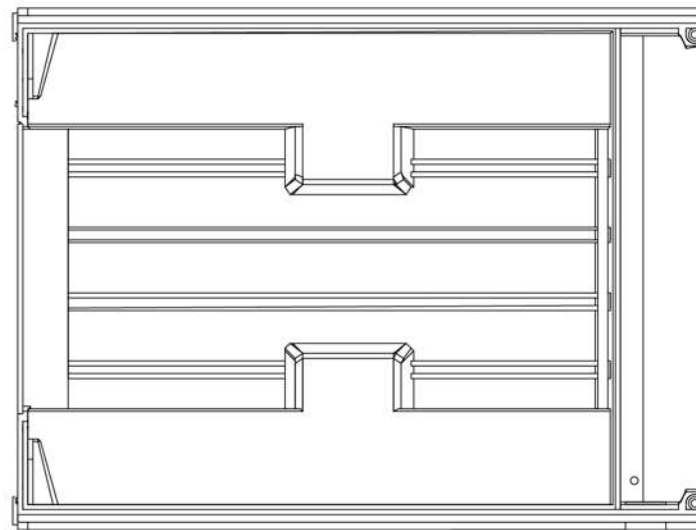

109 Rear Bed
#BRX02302

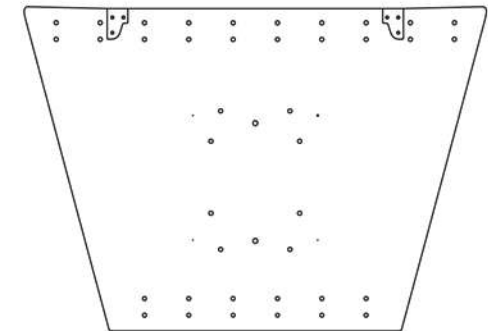

Razor Bonnet
#BRX02349



Stainless Steel Wing Air Intake Filter
#BRX02366

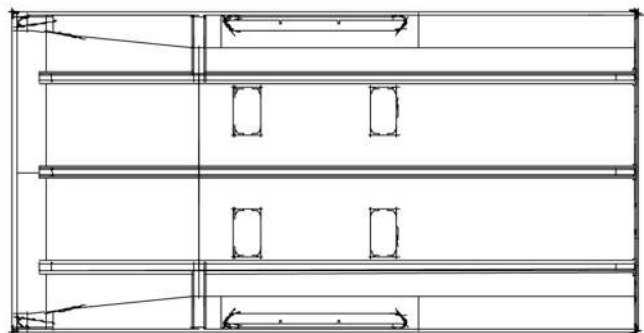

109 Roof Top
#BRX02399

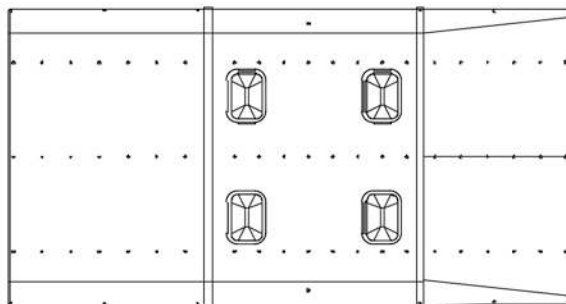

109 Tropical Roof
#BRX02400

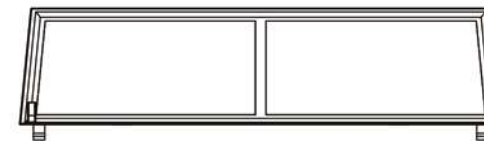

Windscreen Frame
#BRX02313

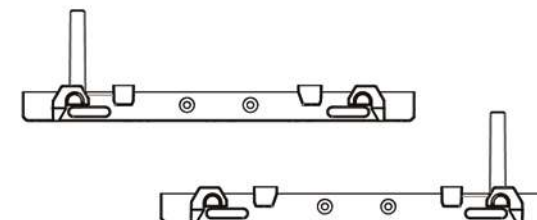

Aluminum Body Brace (Left & Right)
#BRX020112

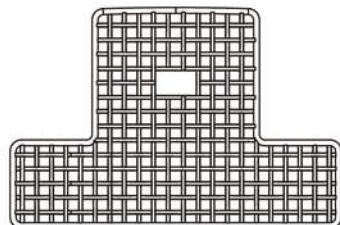

Series II Aluminum Wire Mesh Grille
#BRX02346

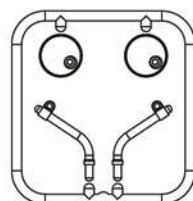

Rubber Side Mirrors
#BRX02347



Land Rover Tub Badge Solihull
(Stainless Steel)
#BRX02361

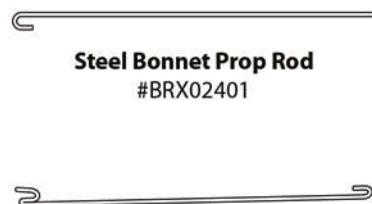

Steel Bonnet Prop Rod
#BRX02401

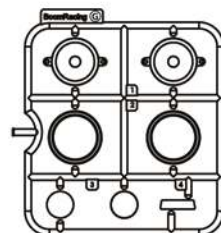

Steel Rear Door Support Rod
#BRX02402

G
#BRX02348

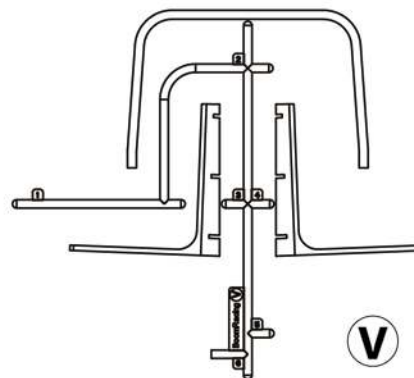

V
#BRX02350

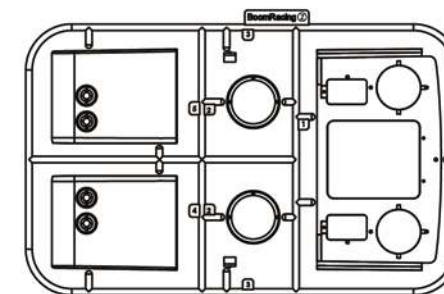

Z
#BRX02351

Note: some parts are not attached to the part trees for packaging reasons.

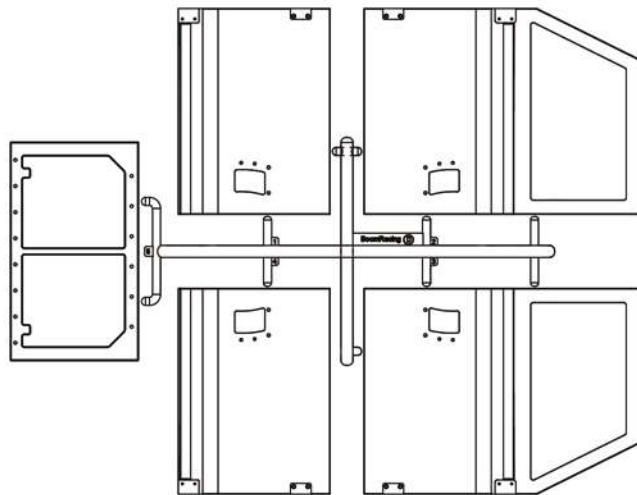

E
#BRX02311

D
#BRX02310

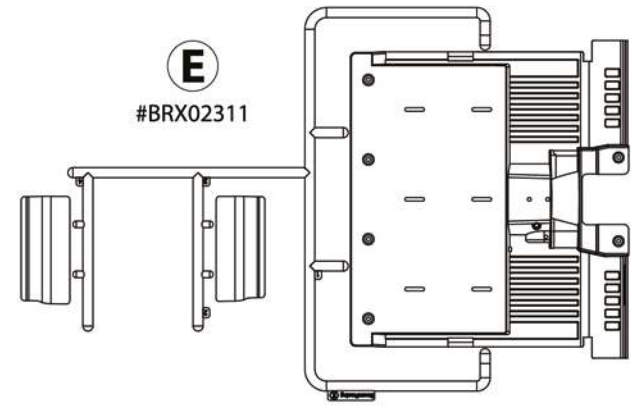

AD
#BRX02404

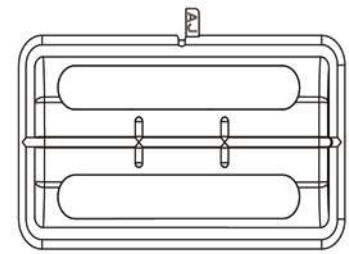
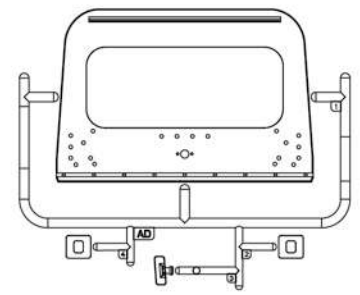

AJ
#BRX02408

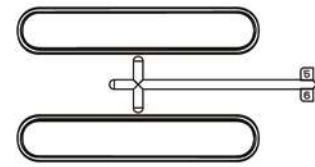

T
#BRX02355

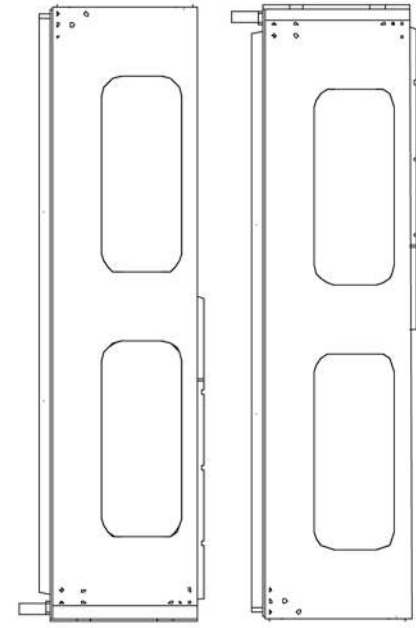

Rear Quarter Panel
#BRX02405

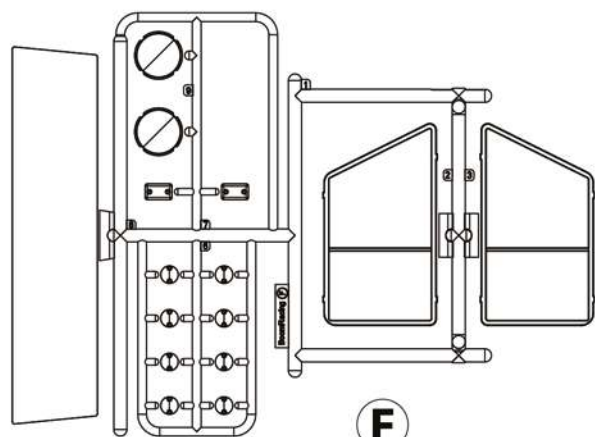

F
#BRX02309

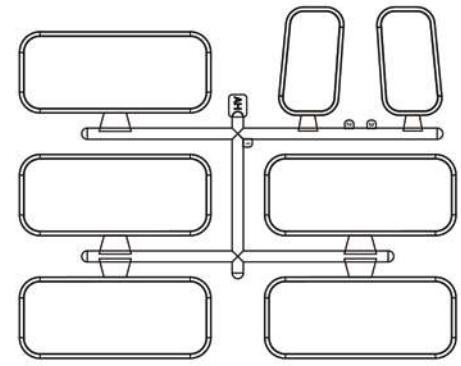

AH White
#BRX02403A

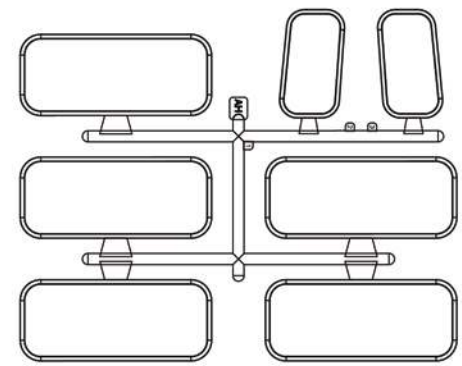

AH Clear
#BRX02403

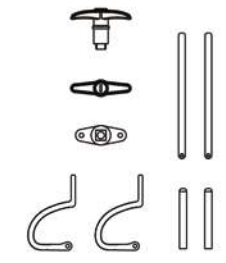

Tailgate Latch Assembly
#BRX02406

Note: some parts are not attached to the part trees for packaging reasons.

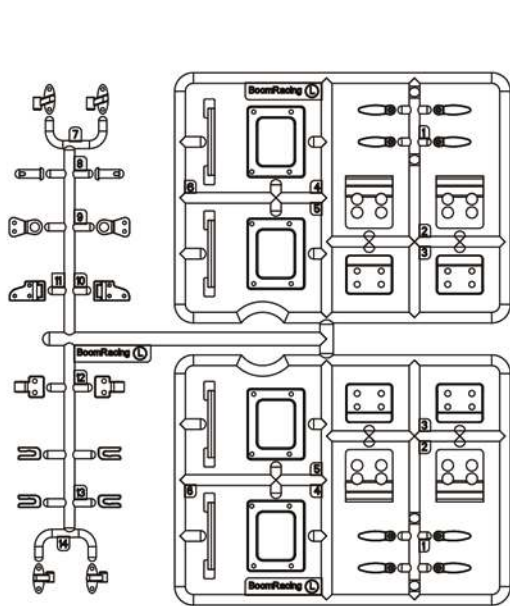

L

#BRX02316

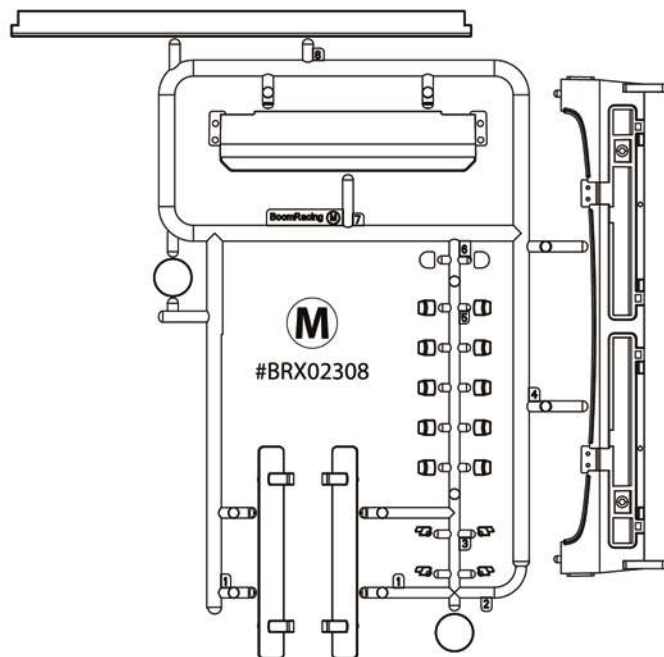

M

#BRX02308

K

#BRX02304

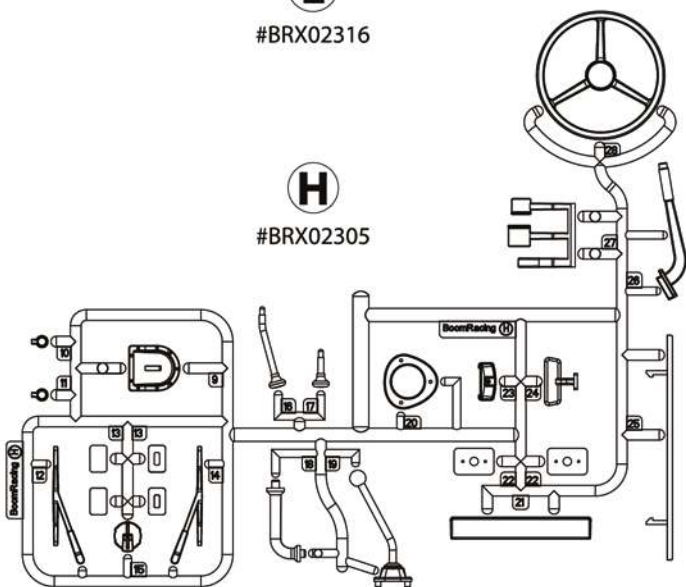
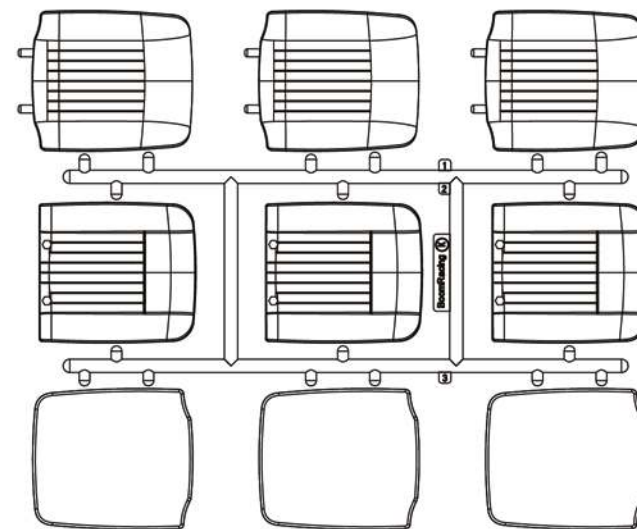

H

#BRX02305

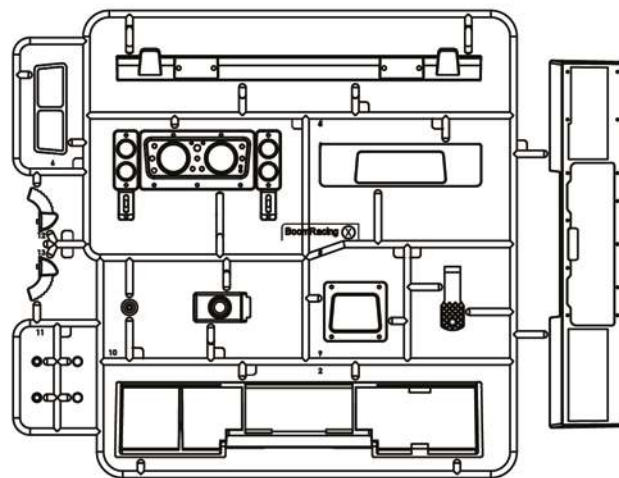

X

#BRX02360

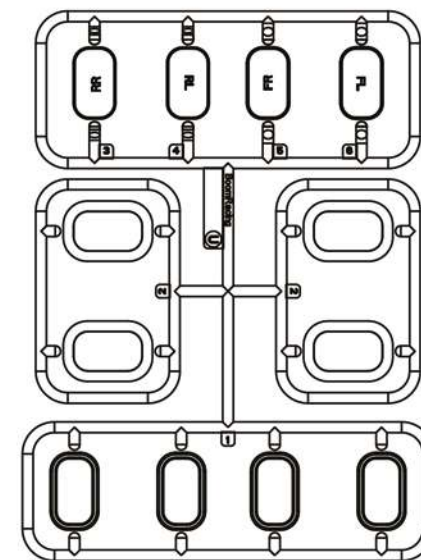

U

#BRX02359



Before you begin, we recommend:

- ① Read through the entire manual prior to starting assembly.
- ② Complete step 1 before painting begins.

Blank Installation Guide

Either blank out both sides (original Series II) or use one blank only and install wing intake on the other side (this blank can be an indication for left or right-hand drive; blank installation on right side for right-hand drive).

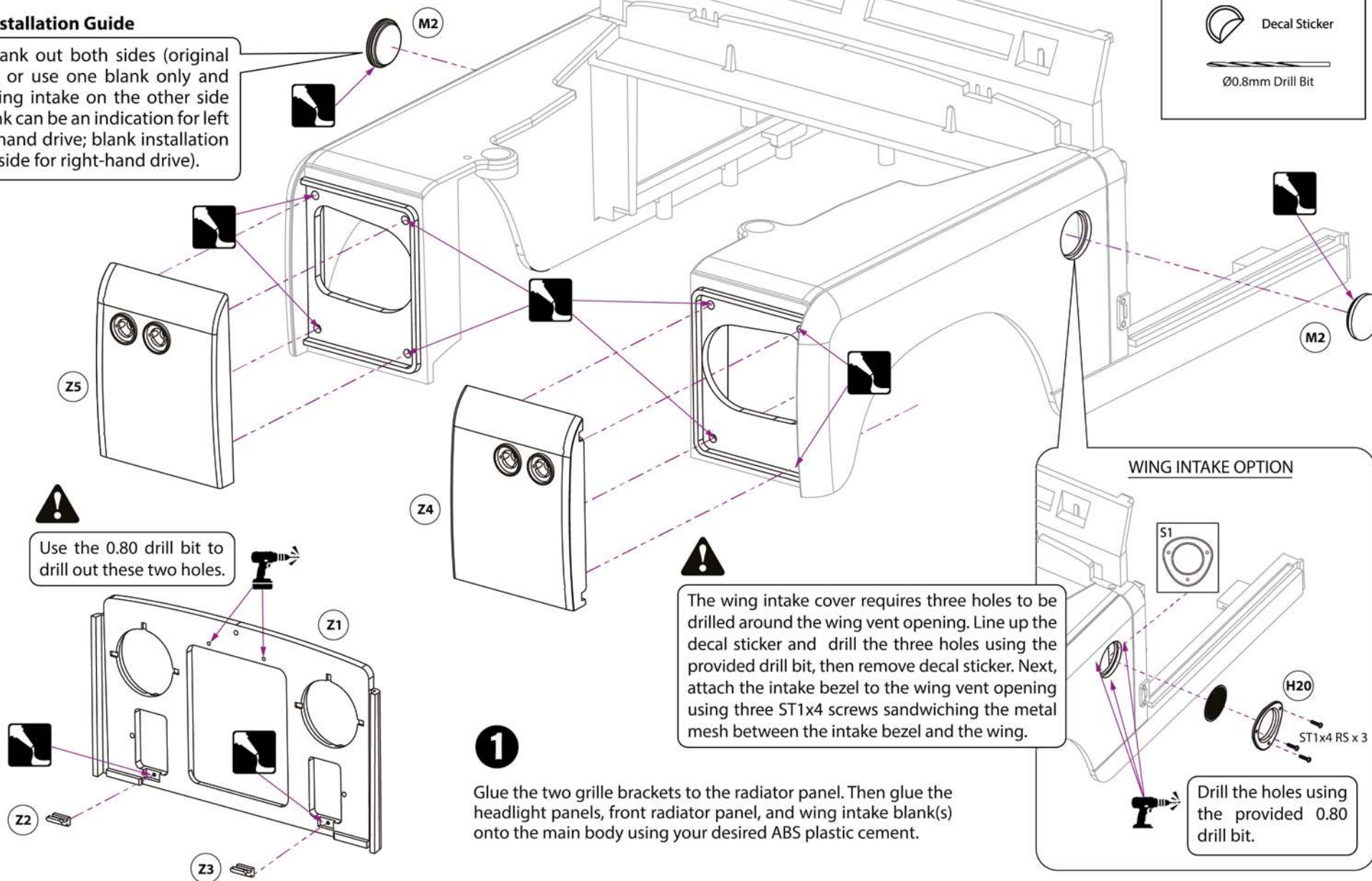

Use the 0.80 drill bit to drill out these two holes.

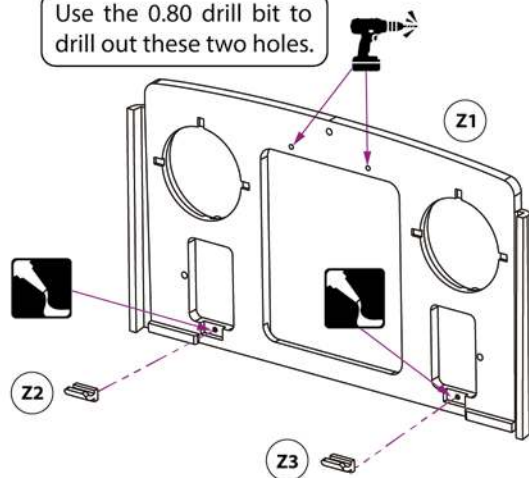

The wing intake cover requires three holes to be drilled around the wing vent opening. Line up the decal sticker and drill the three holes using the provided drill bit, then remove decal sticker. Next, attach the intake bezel to the wing vent opening using three ST1x4 screws sandwiching the metal mesh between the intake bezel and the wing.

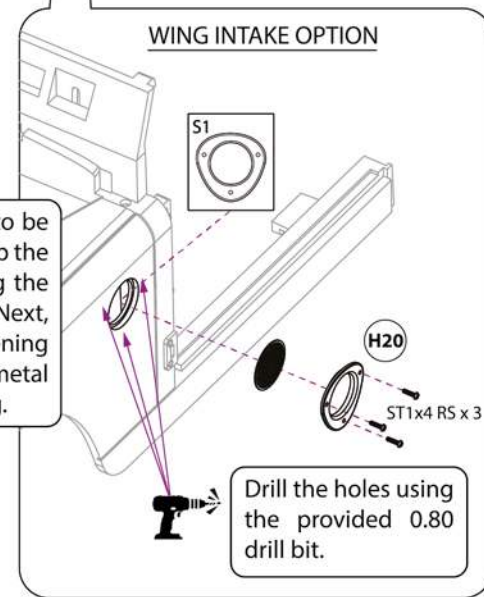

Drill the holes using the provided 0.80 drill bit.

1

Glue the two grille brackets to the radiator panel. Then glue the headlight panels, front radiator panel, and wing intake blank(s) onto the main body using your desired ABS plastic cement.

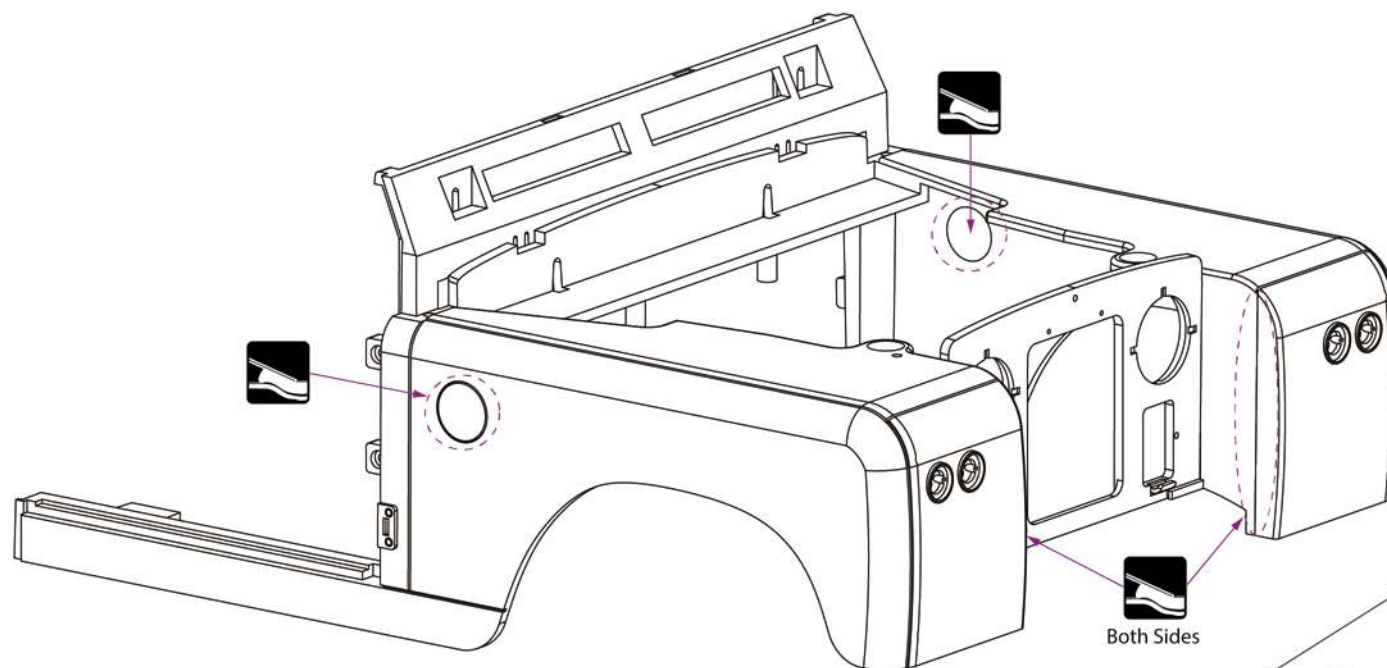

For the best results, we recommend using model filler (not included) to fill in these areas once they are glued together. If model filler is used, sand everything smooth before priming and painting.

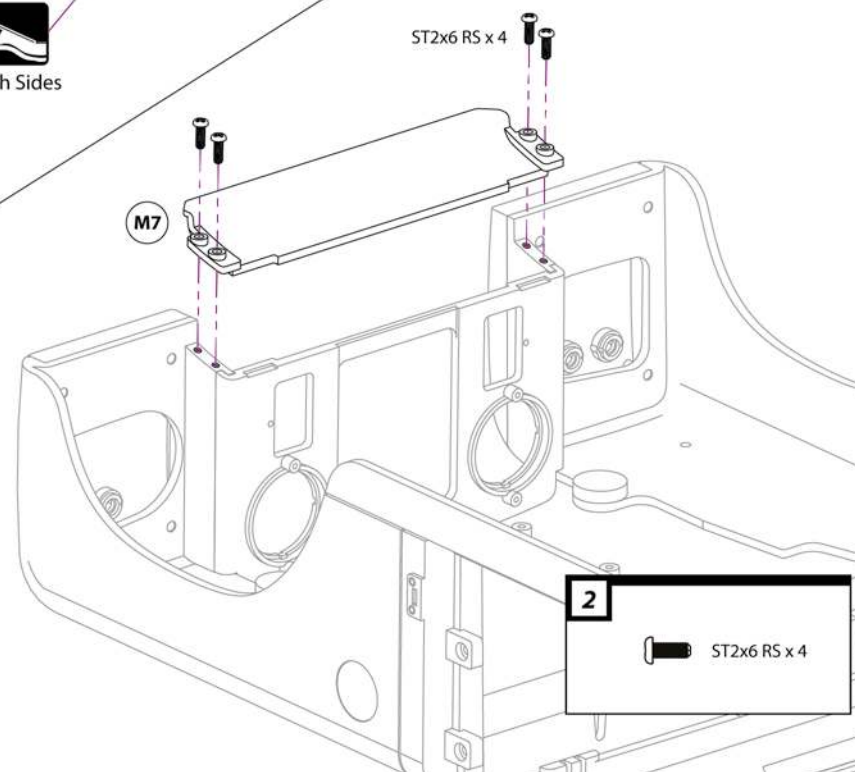

2 Attach the front apron panel using four ST2x6 screws.



ARE YOU BUILDING CHROME LIGHT BEZEL OR PANEL LIGHT BEZEL?

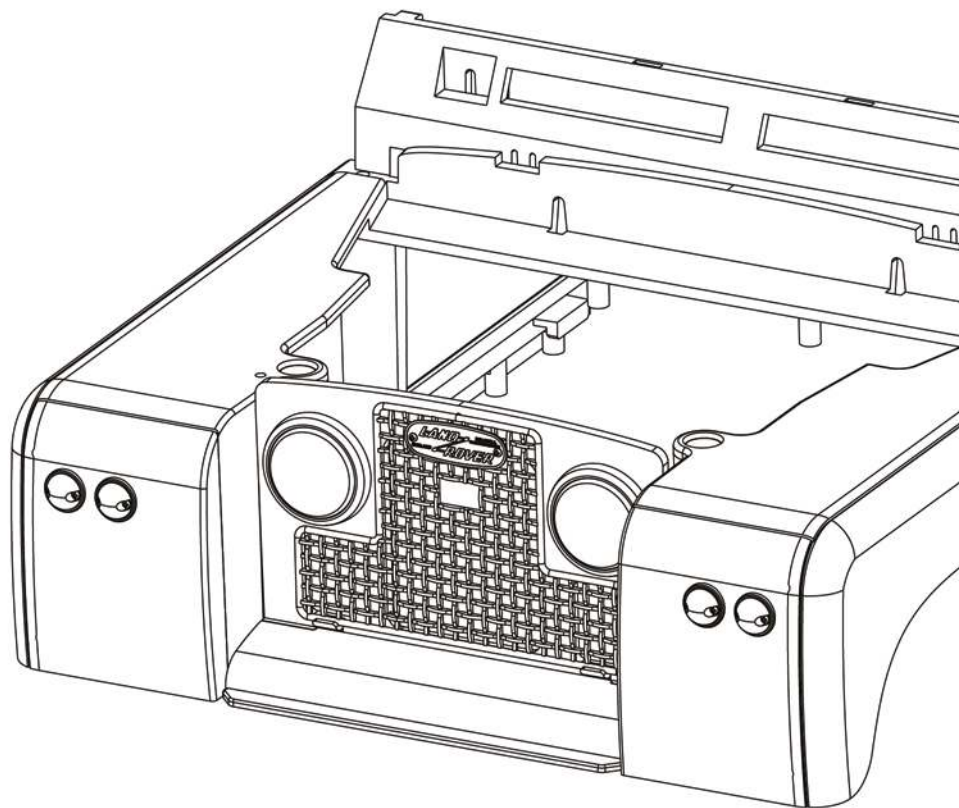

CHROME LIGHT BEZEL

P. 10

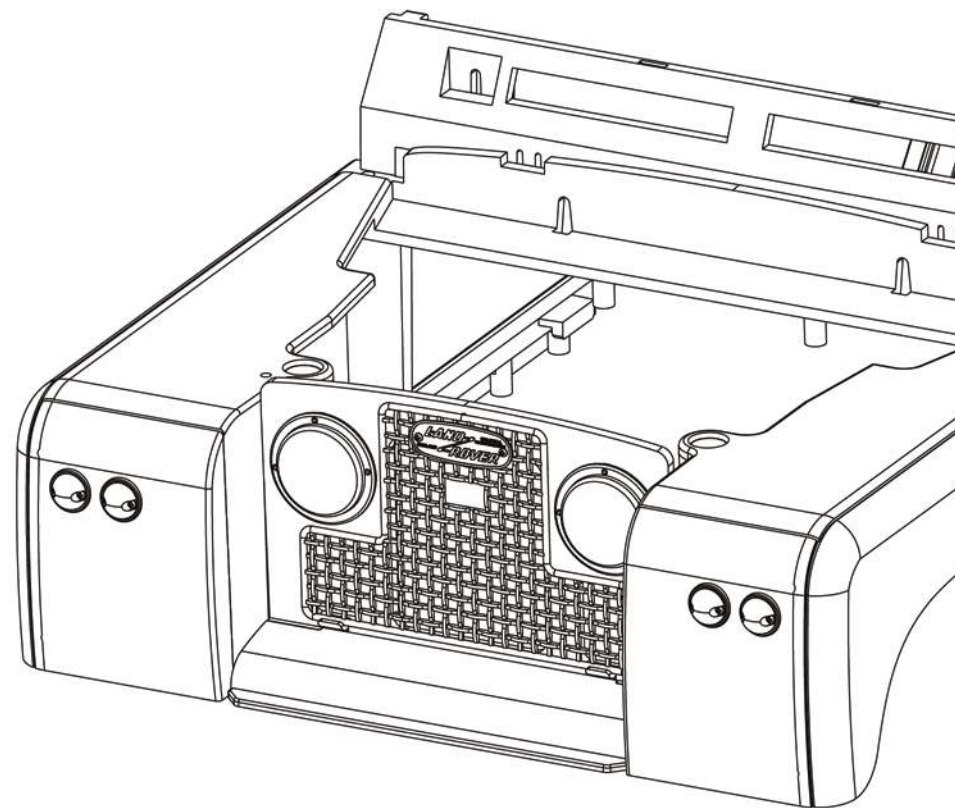

PANEL LIGHT BEZEL

P. 11

Continue to next page if chrome light bezel. Skip to page 11 if panel light bezel.

CHROME LIGHT BEZEL

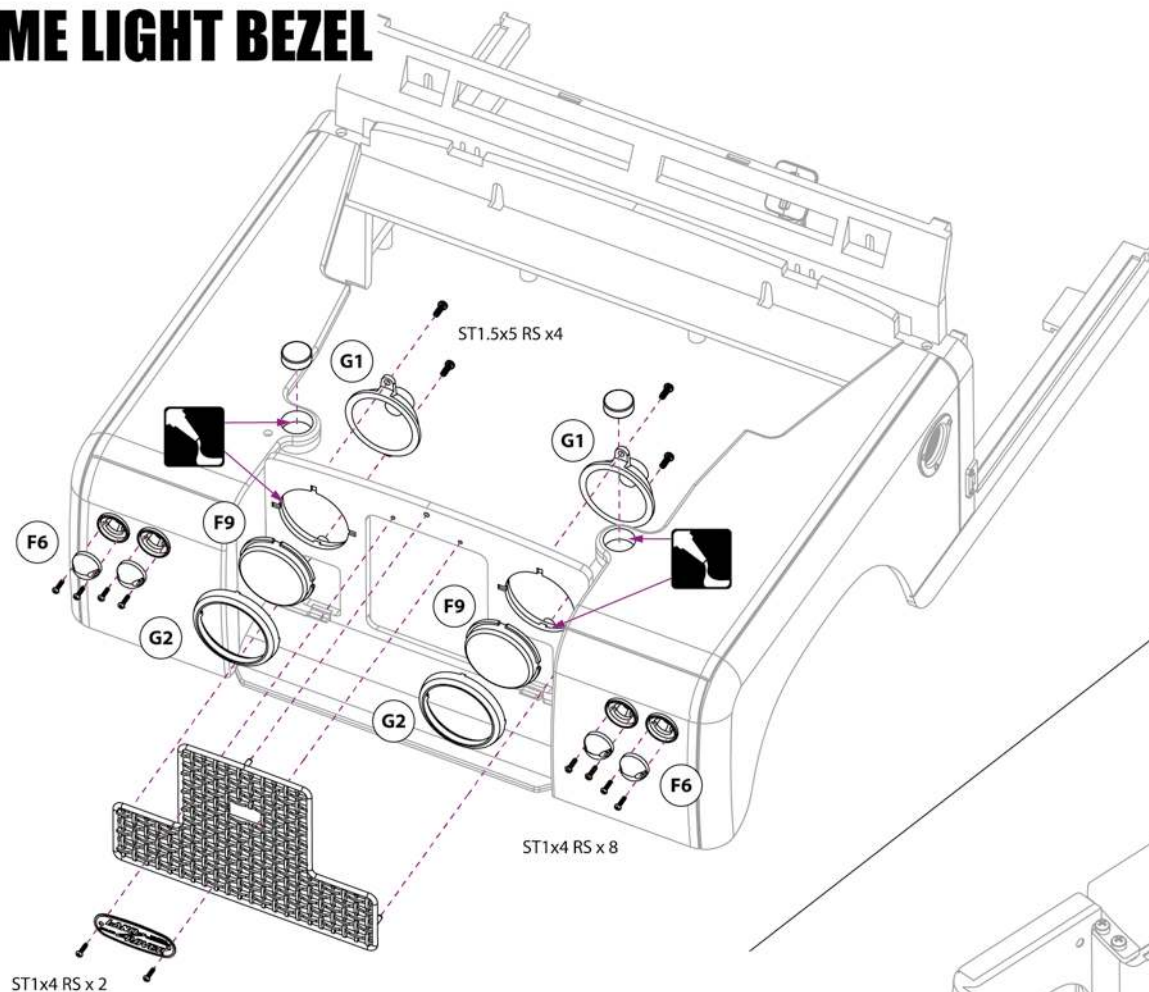

3	ST1x4 RS x10
	ST1.5x5 RS x4
	Magnet OST8x3 x 2

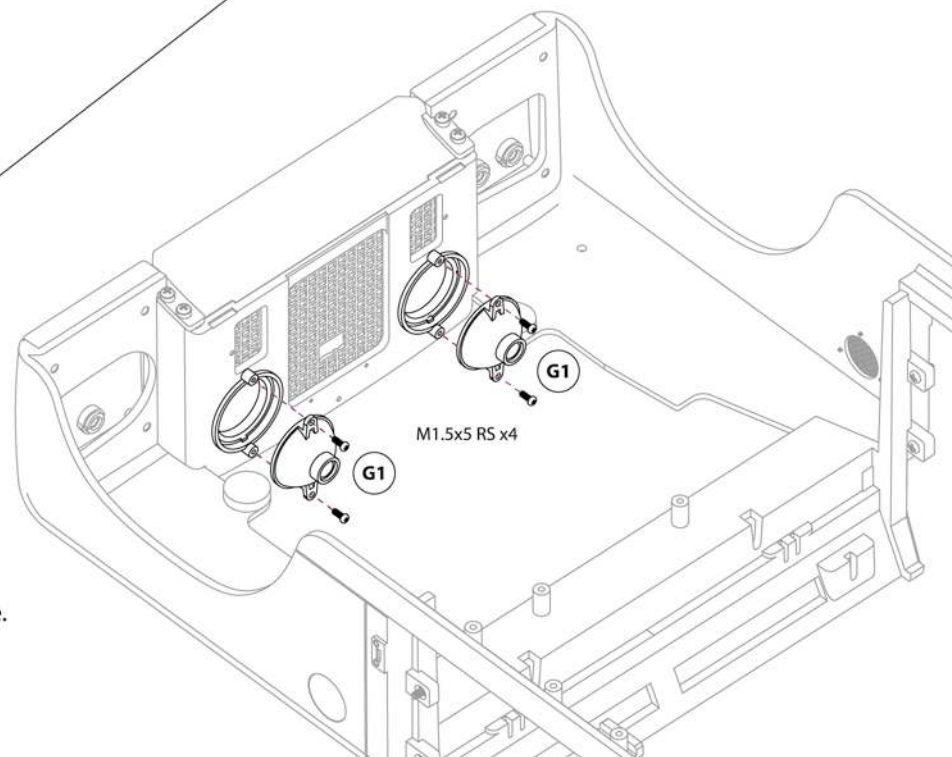

3

To attach the wire mesh grille, rest the bottom onto the two grille brackets and then press the three pins into the holes. Next, attach the Land Rover tub badge with two ST1x4 screws.

Insert the clear headlight lens into the chrome light bezel, ensuring that it lines up with the notches. Glue the headlight lens onto the front grille panel, making sure that the three notches line up before gluing. Then attach the rear light bucket with two ST1.5x5 screws from the back. Repeat on other side.

To install the side light and indicator lenses, use eight ST1x4 screws.

Finally, glue the two 3x8 magnets into the allocated slots.

PANEL LIGHT BEZEL

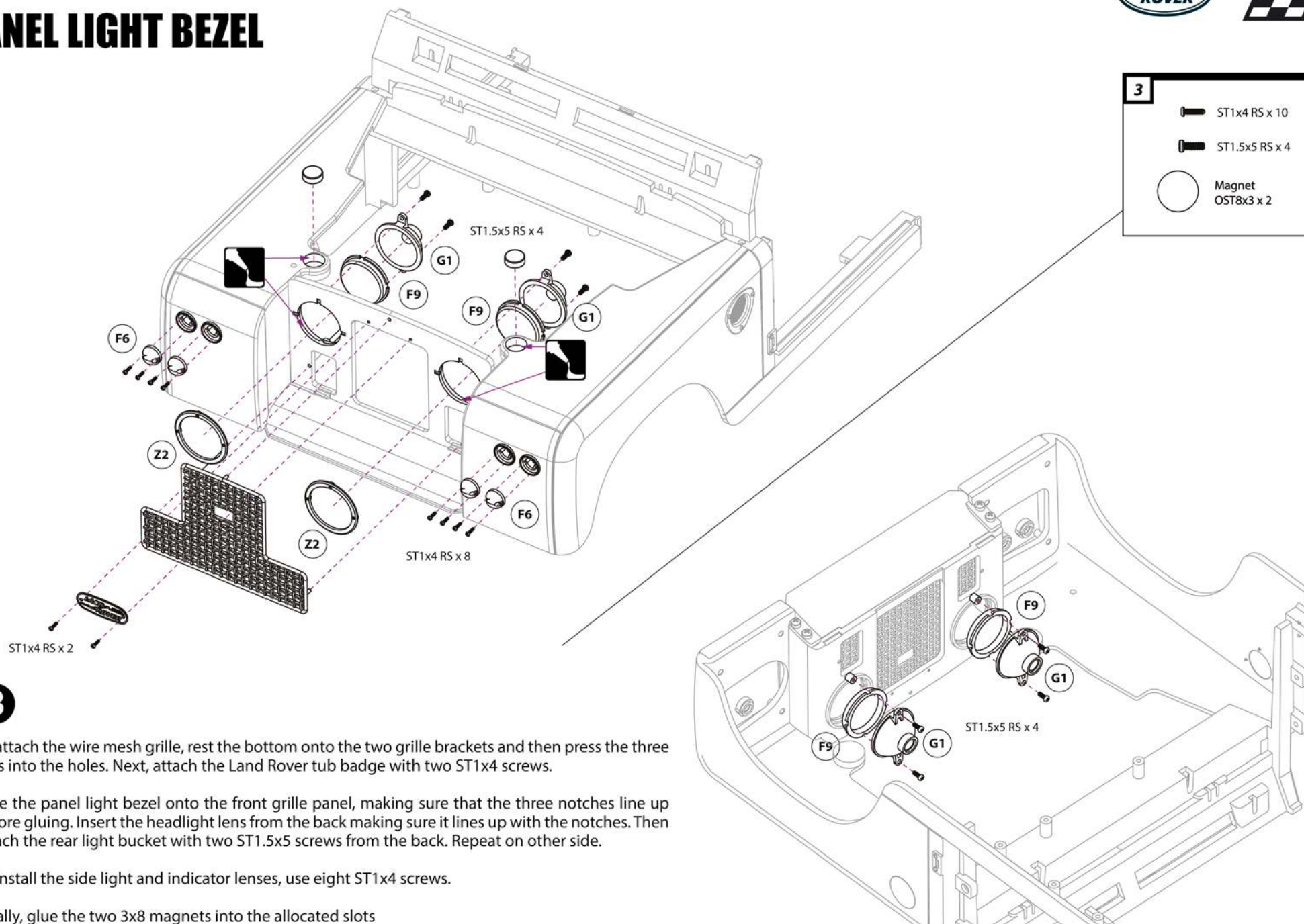

3

To attach the wire mesh grille, rest the bottom onto the two grille brackets and then press the three pins into the holes. Next, attach the Land Rover tub badge with two ST1x4 screws.

Glue the panel light bezel onto the front grille panel, making sure that the three notches line up before gluing. Insert the headlight lens from the back making sure it lines up with the notches. Then attach the rear light bucket with two ST1.5x5 screws from the back. Repeat on other side.

To install the side light and indicator lenses, use eight ST1x4 screws.

Finally, glue the two 3x8 magnets into the allocated slots

4

Pin x 4

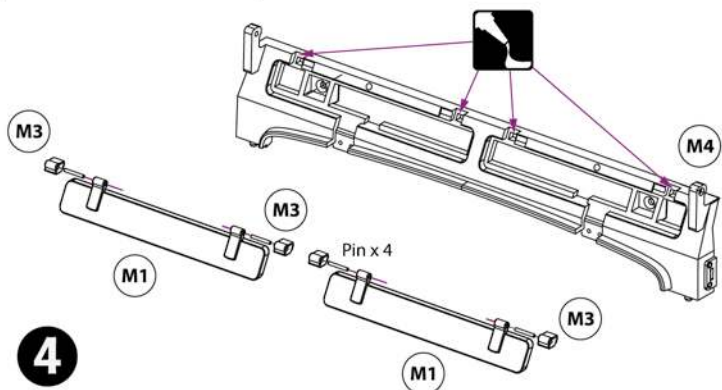

4

Insert pins into the vent flap and vent hinge before gluing onto the vent panel.

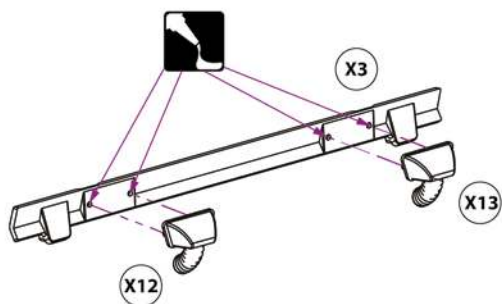

5

Glue the two intakes to the upper dash panel.

6

ST2x8 CSS x 2

ST1.5x5 RS x 4

6

Attach the vent panel to the front main body. Attach the upper dash panel with two STCS2x8 screws and the bonnet hinge with four ST1.5x5 screws.

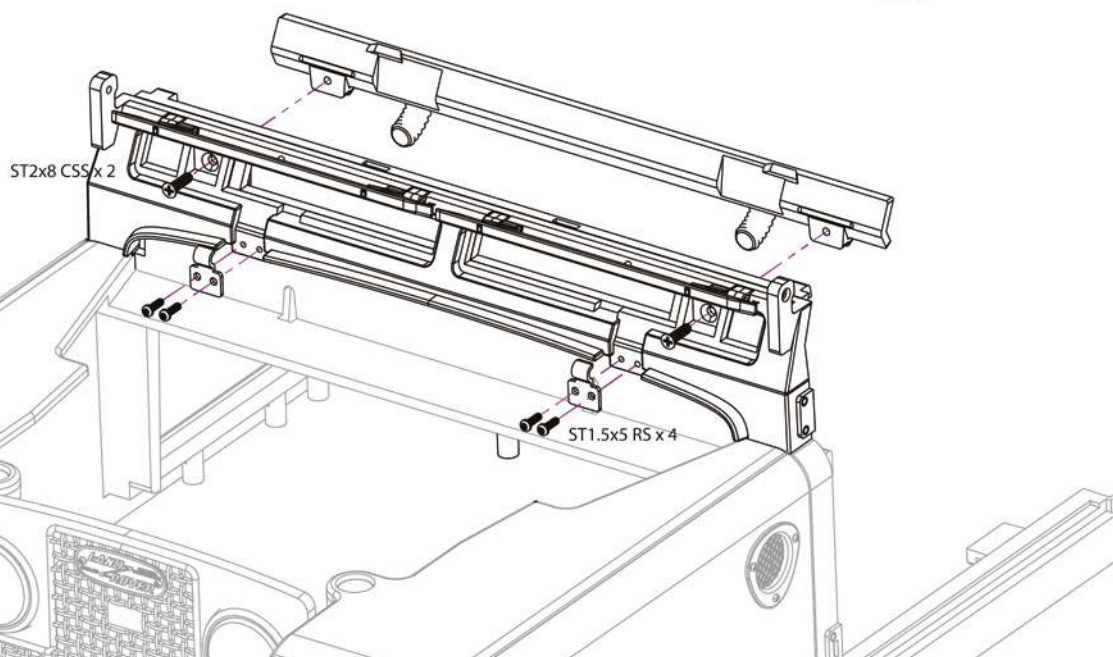
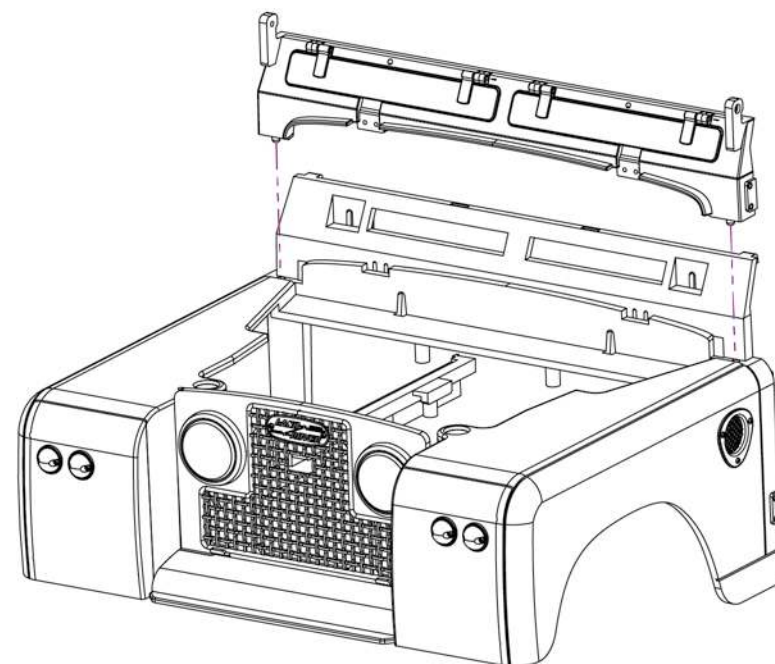

7

Attach the gear stick, hi/low stick, 2WD/4WD stick, handbrake and foot pedals with a touch of glue to the interior floor panel.

8**x3**

Glue the front and rear back rest together, then glue it to the seat base.

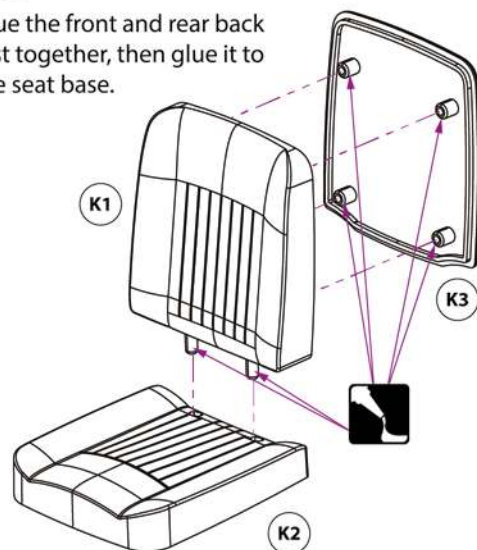
**9**

ST2x6 RS x 6

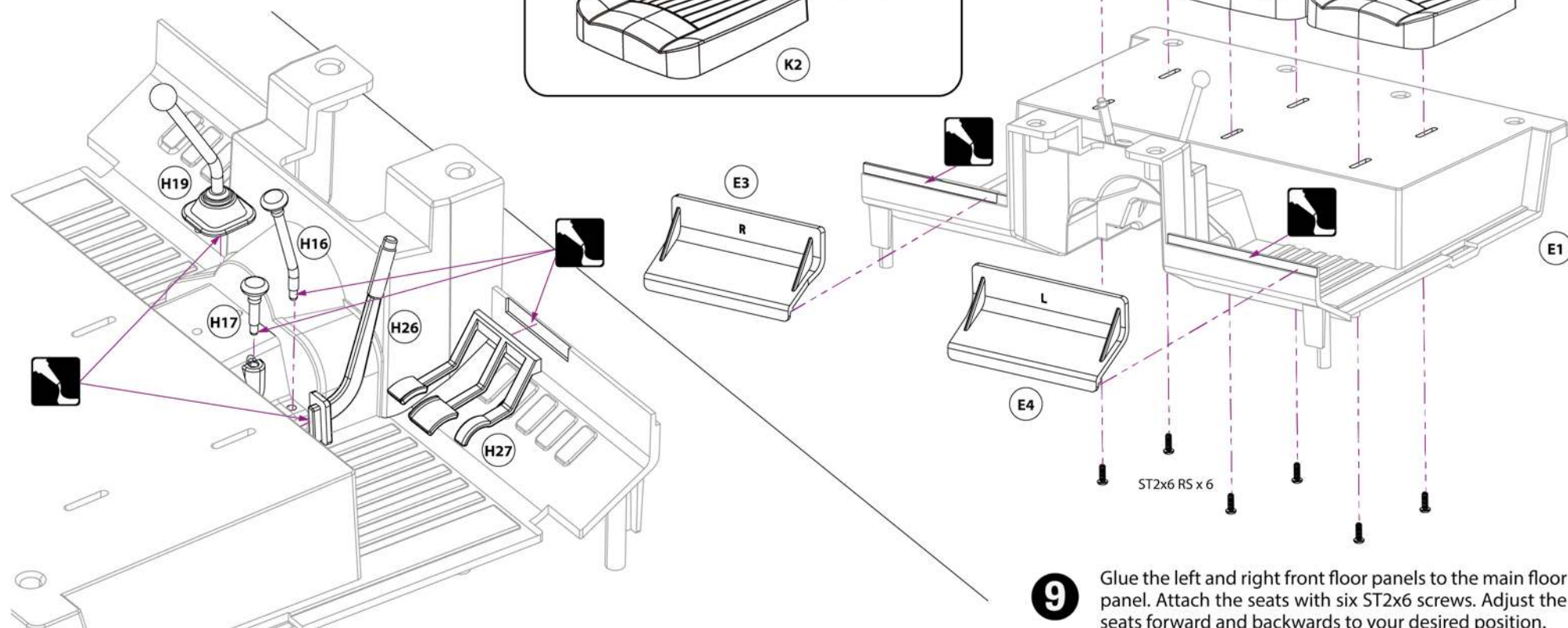
**9**

Glue the left and right front floor panels to the main floor panel. Attach the seats with six ST2x6 screws. Adjust the seats forward and backwards to your desired position.

10

ST1.2x8 x 2

ST1.2x4 x 10

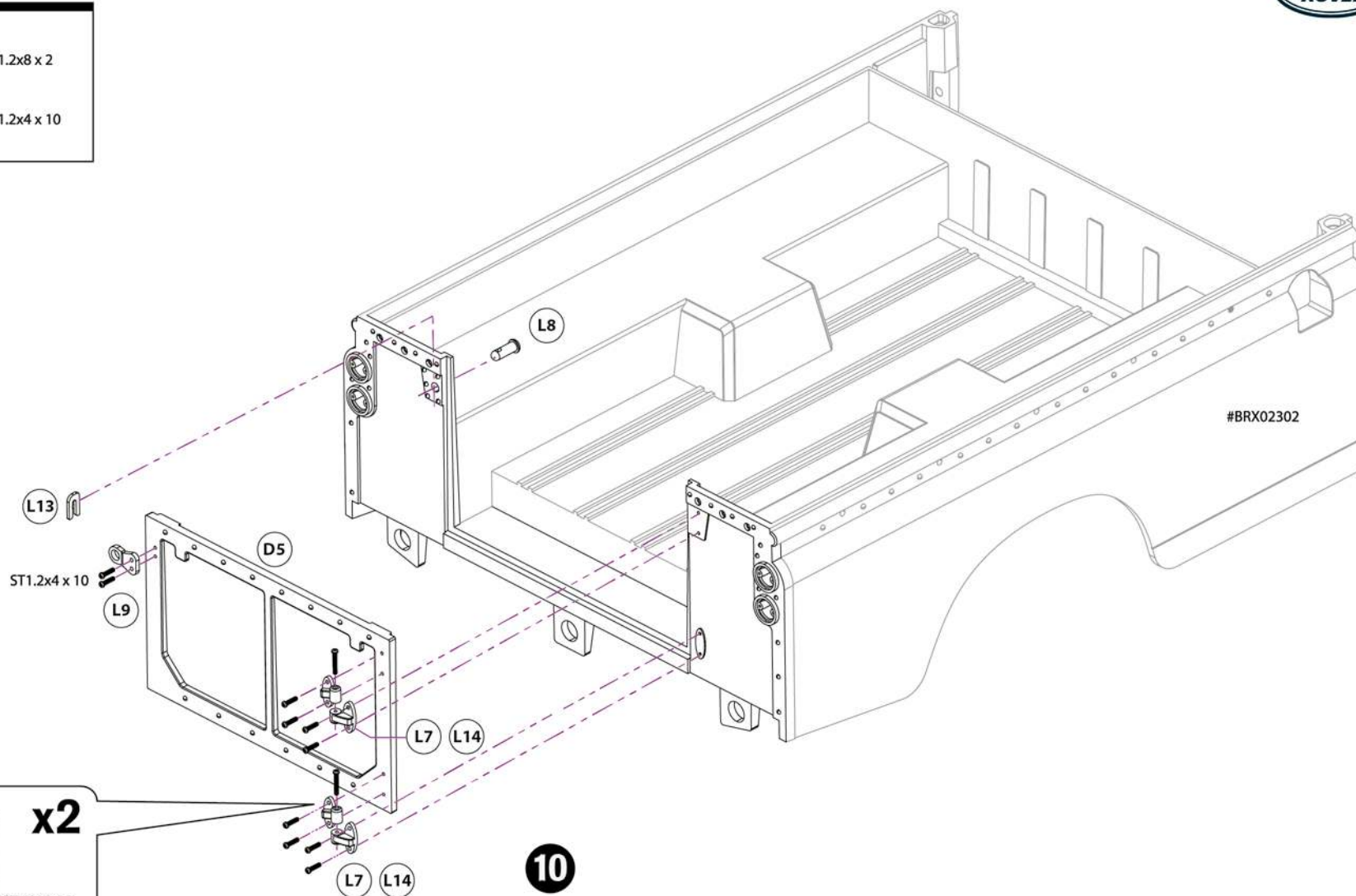

10

Assemble two tailgate hinge assemblies using one ST1.2x8 screw each. Attach the tailgate latch and the two tailgate hinge assemblies to the tailgate using six ST1.2x4 screws.

Insert the tailgate latch pin into the provided hole on the bed.

Attach the tailgate to the bed using four ST1.2x4 screws. Insert the tailgate lock into the tailgate latch and pin to secure the tailgate.

11

ST1x6 x 4

ST1x4 x 8

Decal Sticker

Ø0.8mm Drill Bit

Ø2.0mm Drill Bit

Ø3.0mm Drill Bit

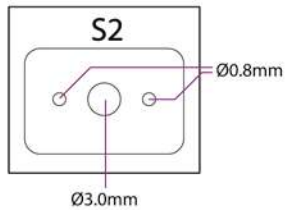
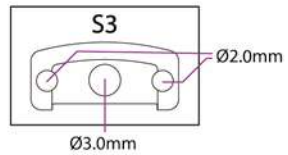

For the rear square lights and rear number plate light, choose where you would like to position them. Use the provided decal sticker to drill the holes for the lights, 3mm for LED / 0.8mm for screws, then remove the decal sticker. Next, attach the square lights with four ST1x6 screws. The number plate light you have to drill two 2.0mm holes and attached with a dab of glue. Every Series III was different depending on regional laws, so we leave that placement up to you.

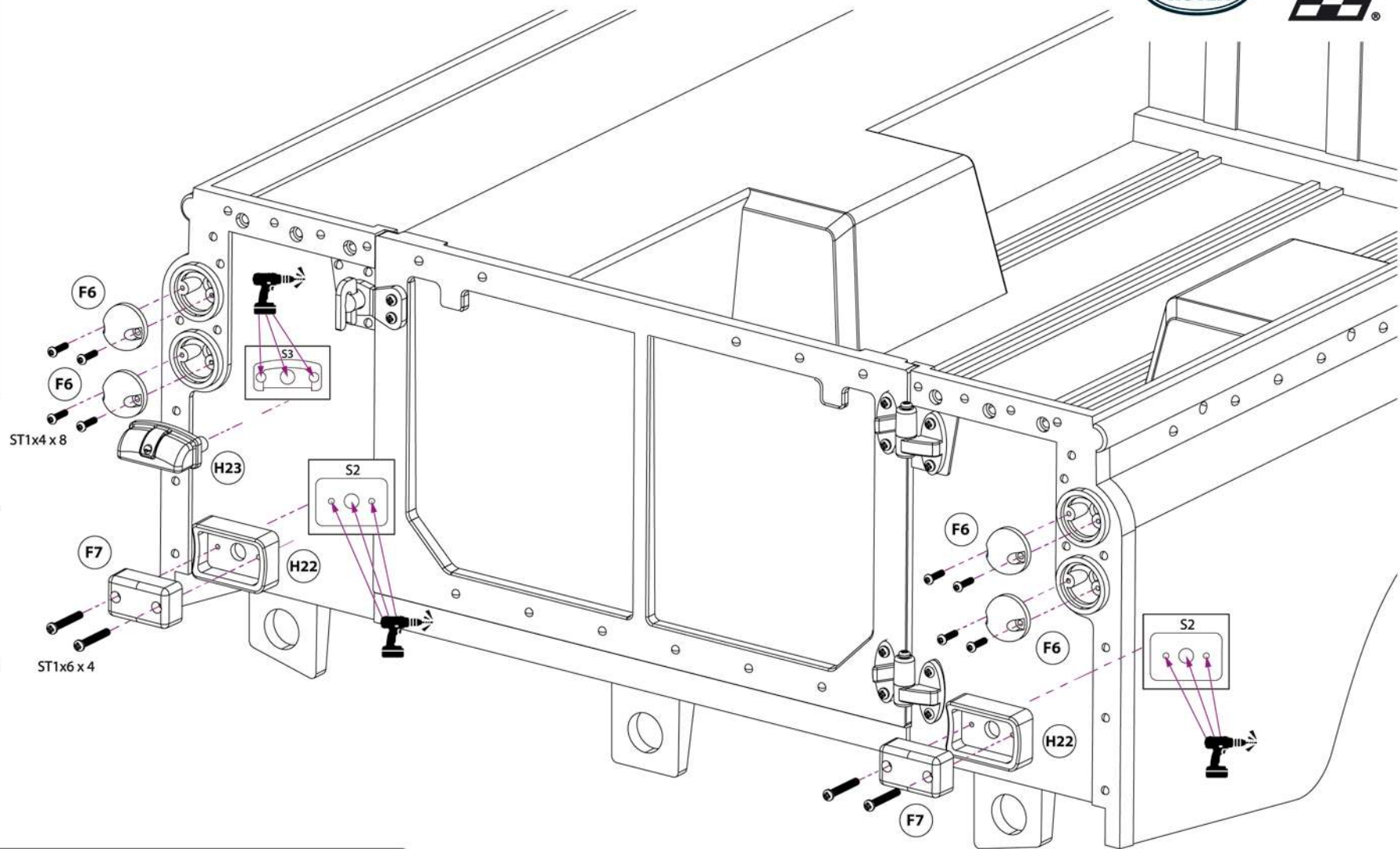

11

Attach rear light lenses with eight ST1x4 screws.

12	
	D3x4 x 4

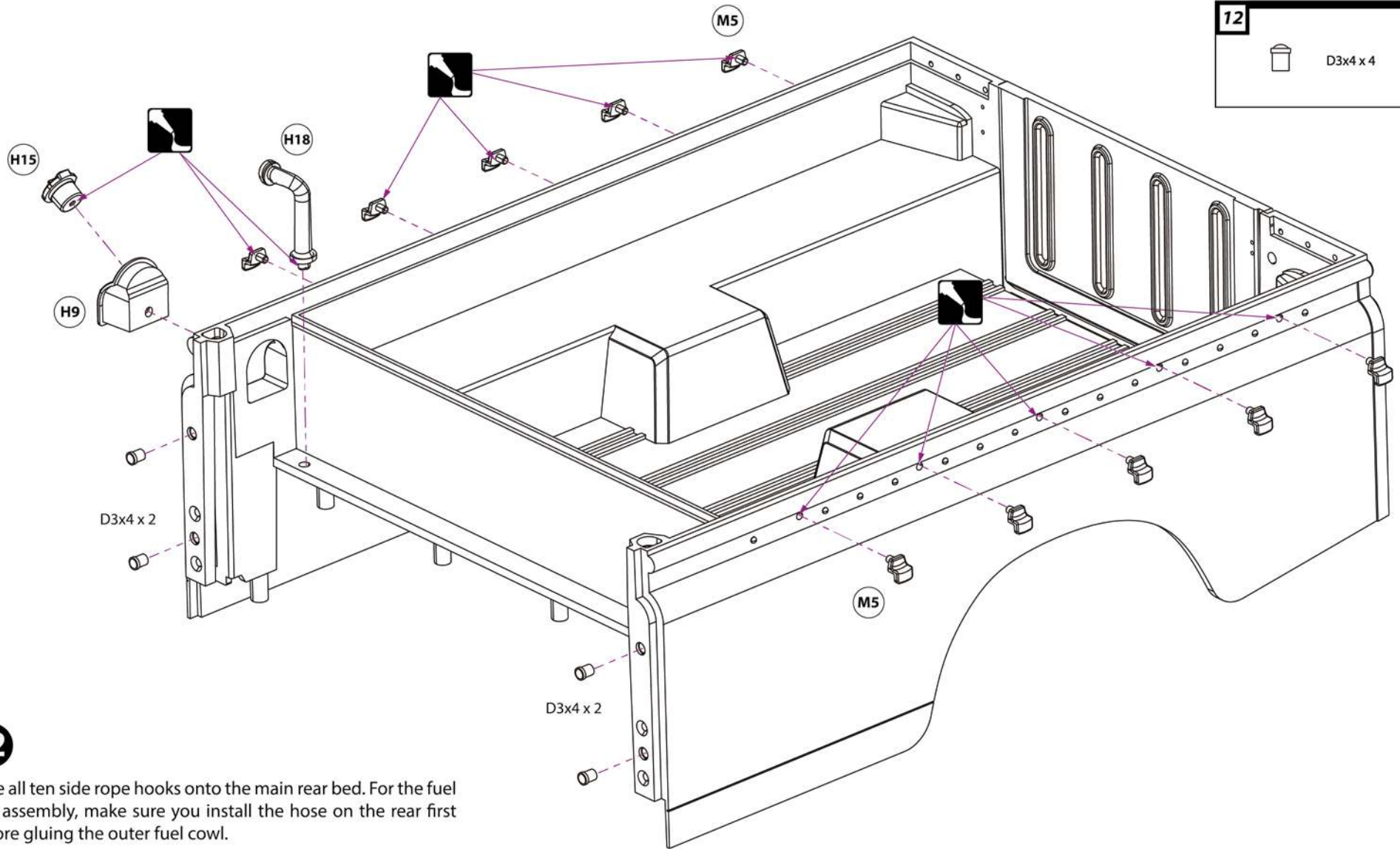

12

Glue all ten side rope hooks onto the main rear bed. For the fuel cap assembly, make sure you install the hose on the rear first before gluing the outer fuel cowl.

Insert four D3x4 spring plunger catch into the bed as indicated.



ARE YOU BUILDING A HARDTOP OR CONVERTIBLE TRUCK?

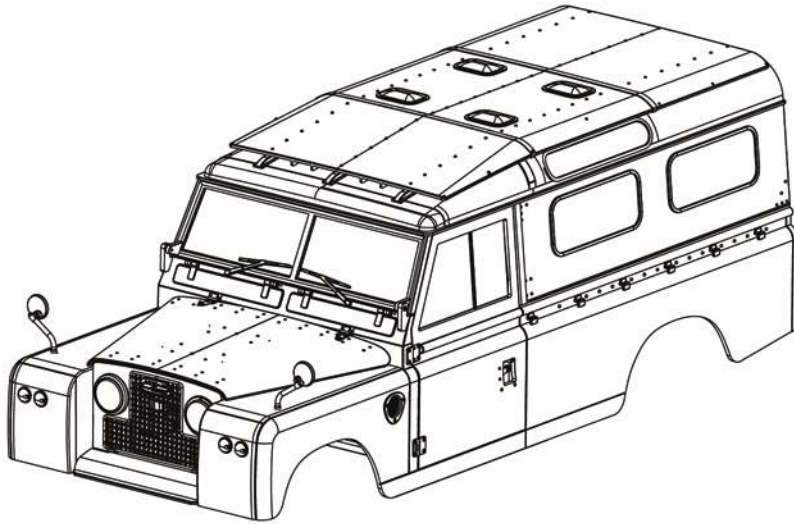

HARDTOP

P. 18

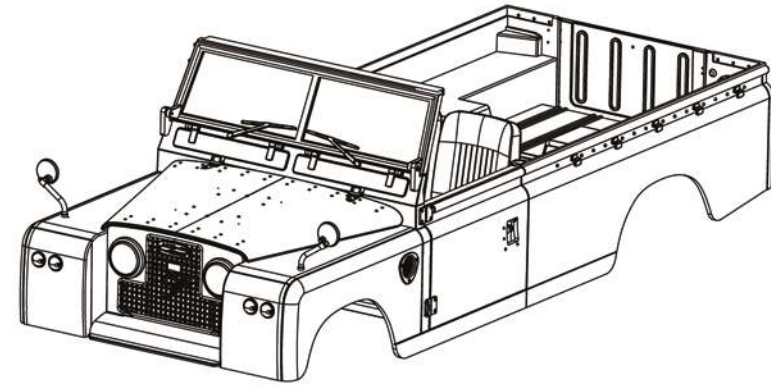

CONVERTIBLE

P. 36

Continue on this page for Hardtop build.



PICK YOUR SIDE MIRROR LOCATION

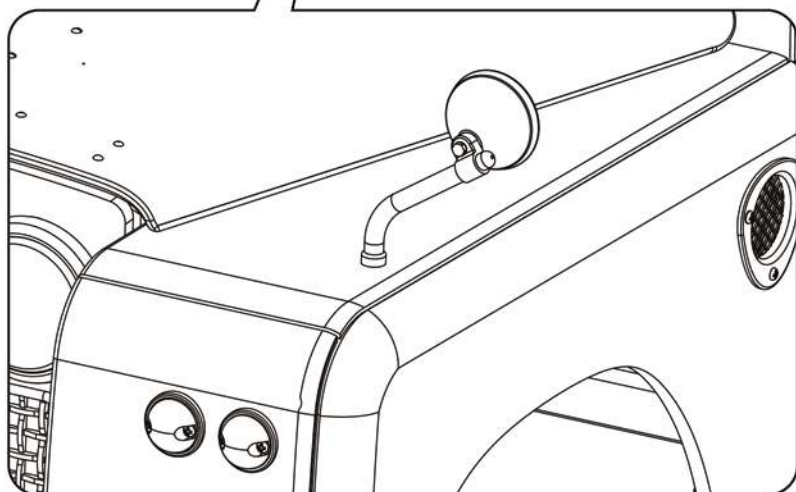
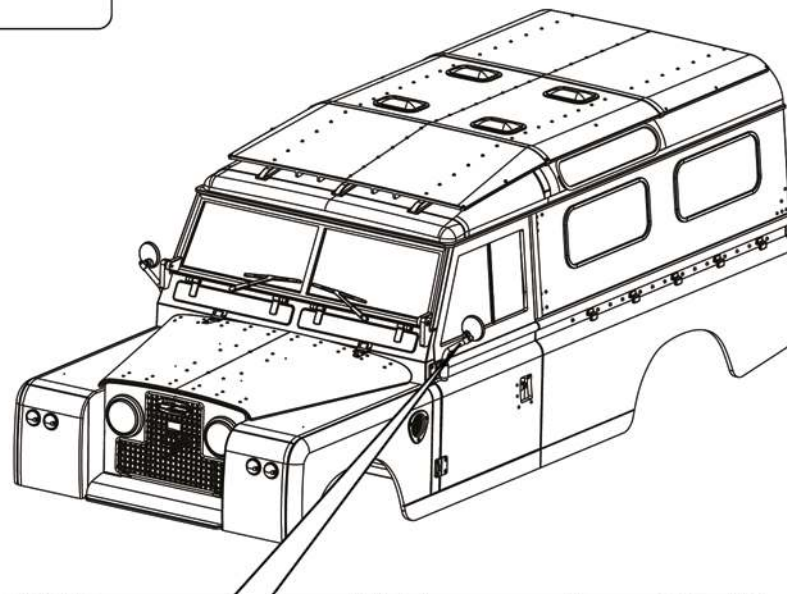
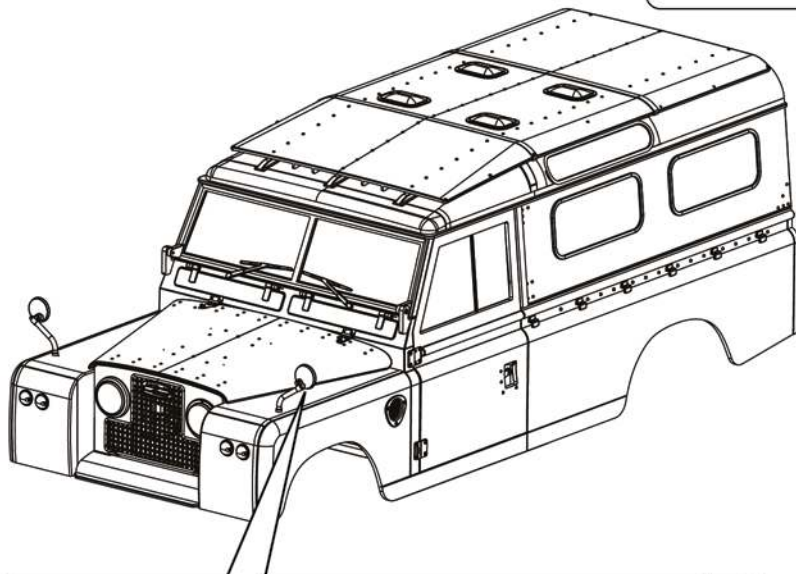

FENDER MIRRORS

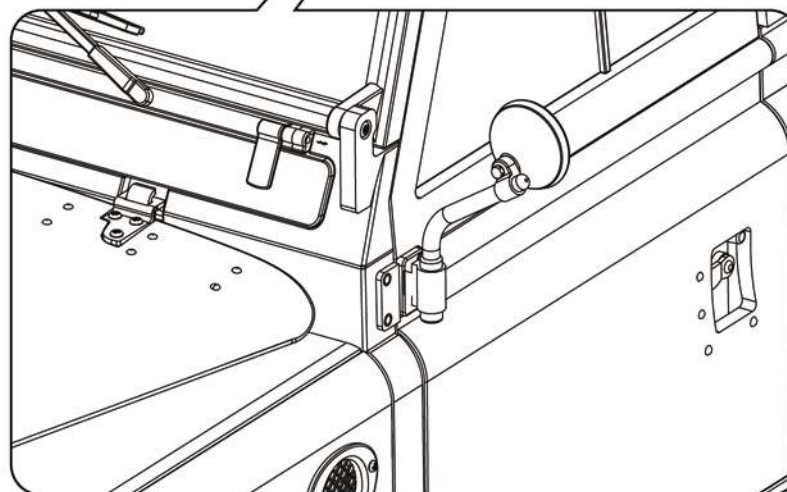

DOOR MIRRORS

FENDER MIRRORS

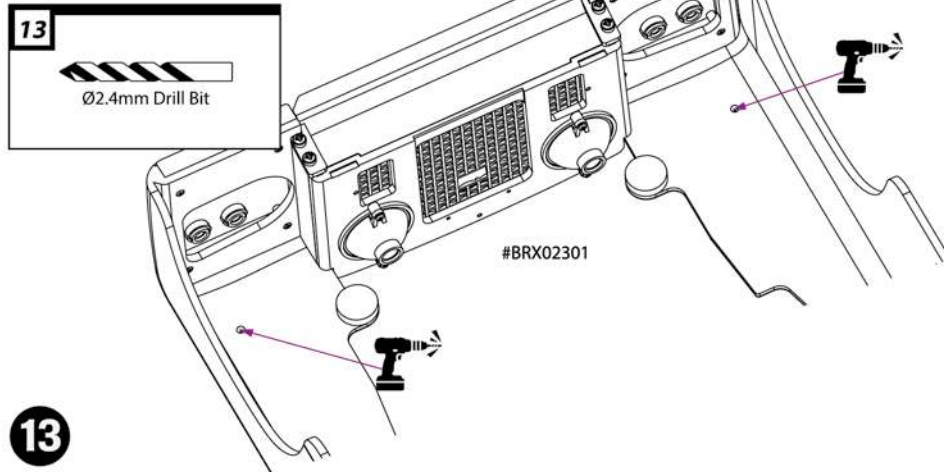

13

Drill two 2.4mm holes into the front main body from underneath as indicated. Use the provided double-sided tape (thin) to stick the mirror plate to the rubber mirror head and push the head into the mirror arm. Push the mirror arm into the holes that you just drilled. Then glue from the bottom into position. Repeat on the other side. Also on the door, stick the door blanking plate on both doors.

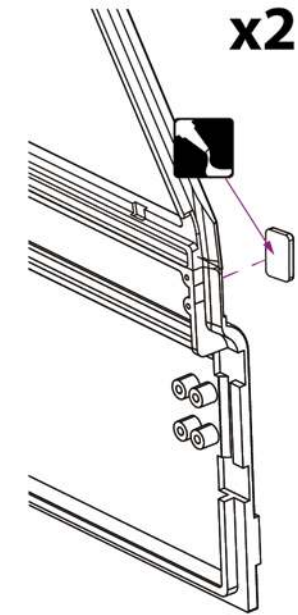
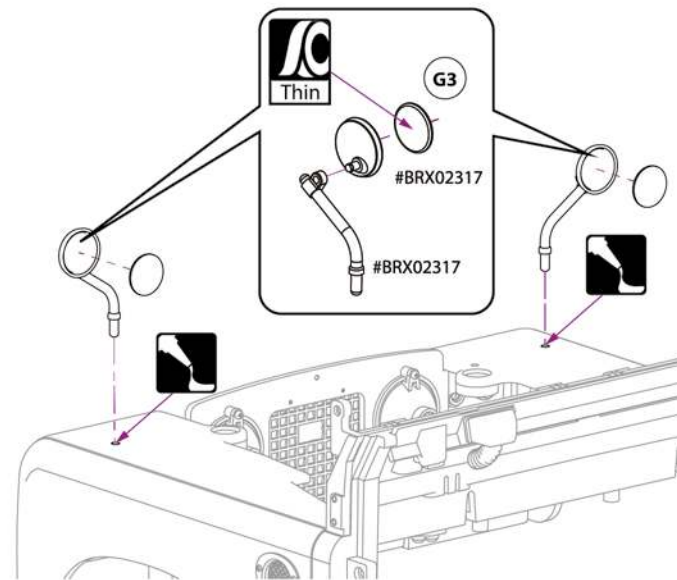

DOOR MIRRORS



13

Use the provided double-sided tape (thin) to stick the mirror plate to the rubber mirror head and push the head into the mirror arm. Glue the mirror arm to the mirror arm holder. Next, glue the assembly to the mirror retaining plate, and then glue the whole assembly to the door. Repeat for the other side.

Clip the clear side window into position. Insert the inner and outer door handles into the door and door lock plate and glue into position. Attach door hinge using four ST2x5 screws. Repeat on the other side.

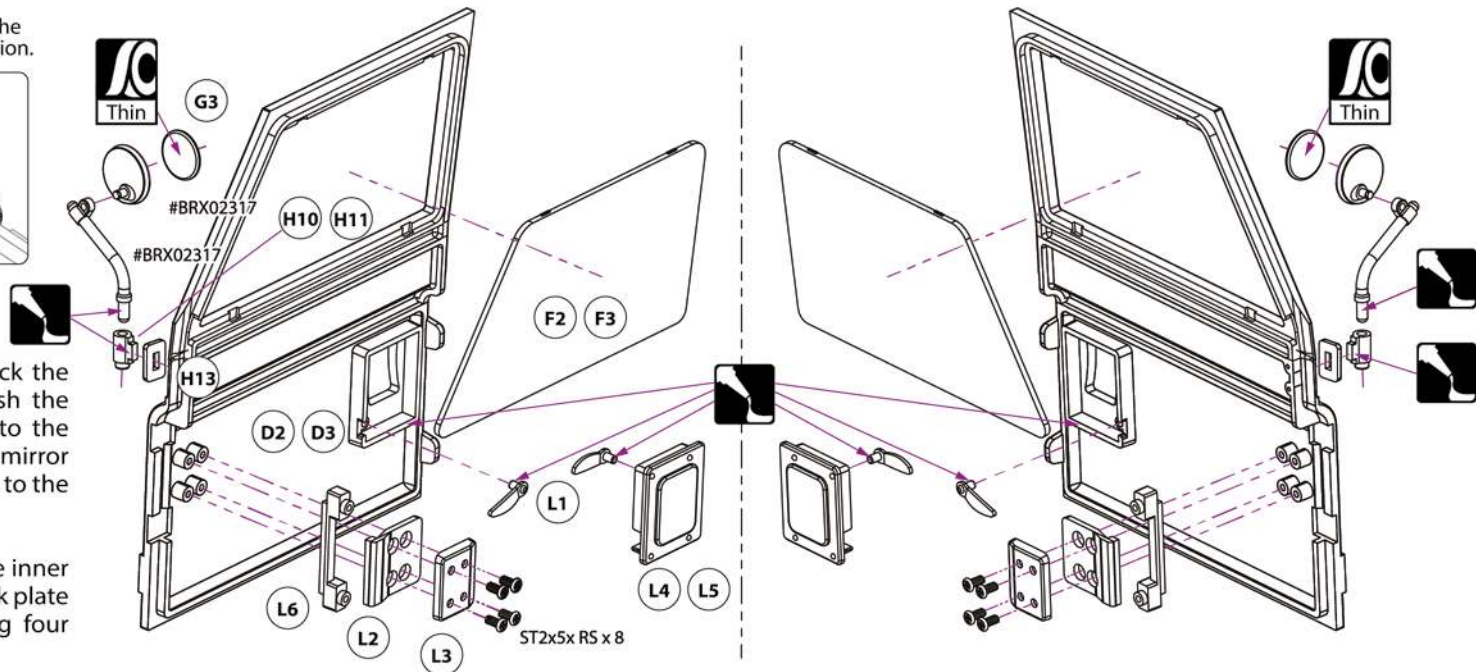

14

Attach the left and right doors to the front main body with four ST2x6 screws.

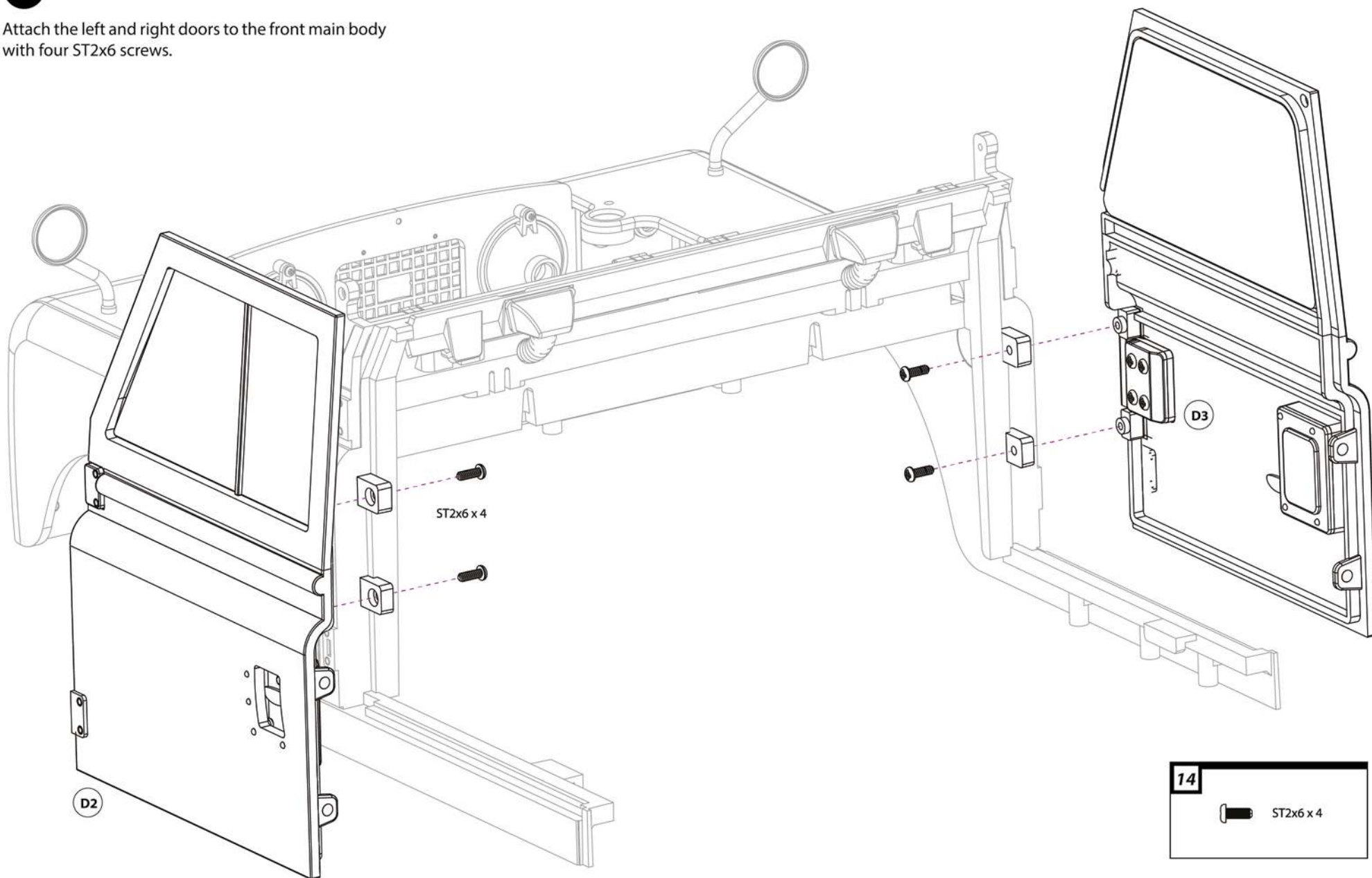

HARDTOP

HARDTOP

15

To build the dash panel, glue the steering column to the rear piece first, then glue the front and rear pieces together.

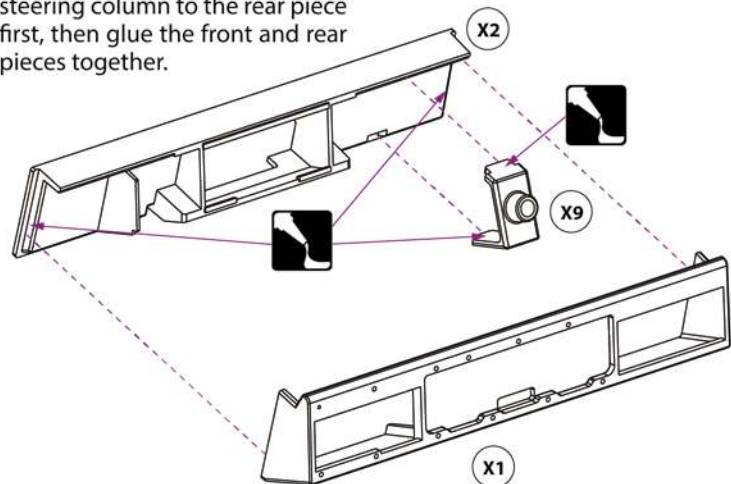

16

Attach the two decals to the instrument plate and place into the dash panel. Glue the four dash controls to the outer instrument panel and attach it to the dash panel with nine ST1x4 screws. Attach the side panel with four ST1x4 screws. Insert steering shaft into steering column and attach the steering wheel.

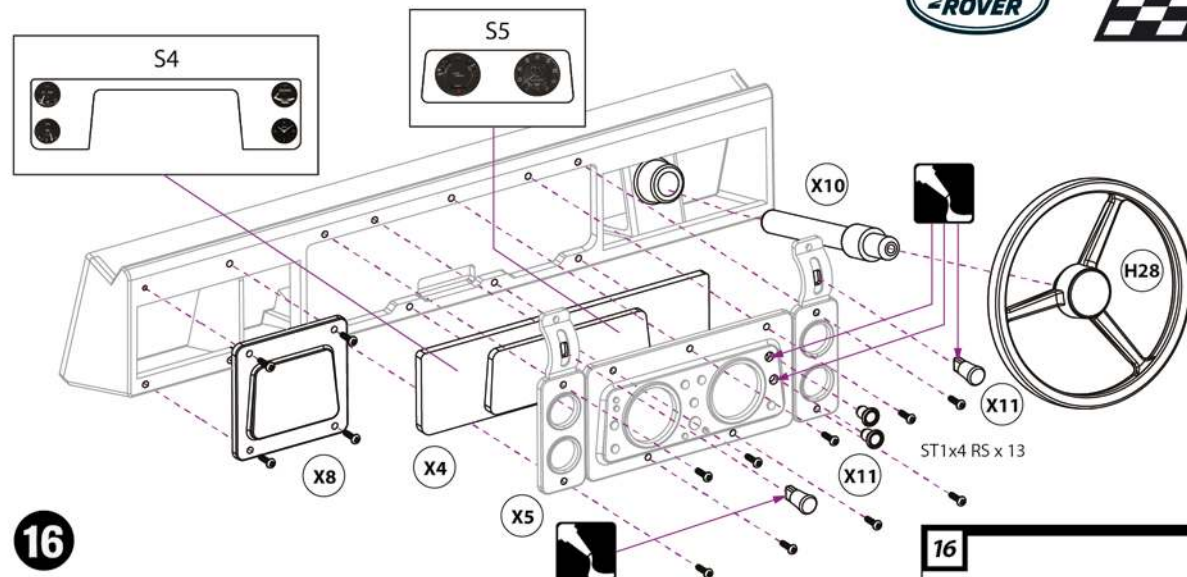

17

Attach the dash panel to the front main body with two ST2.6x6 screws.

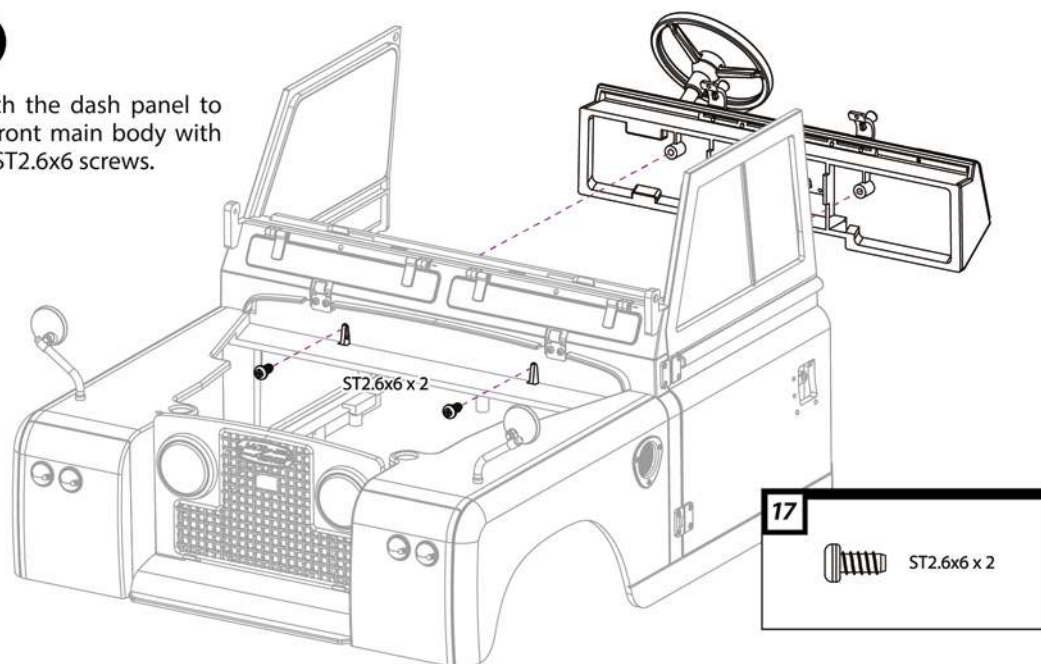

18

Once the dash panel is installed, drill two (0.8) holes into the upper dash panel as indicated and attach with two ST1x4 screws.

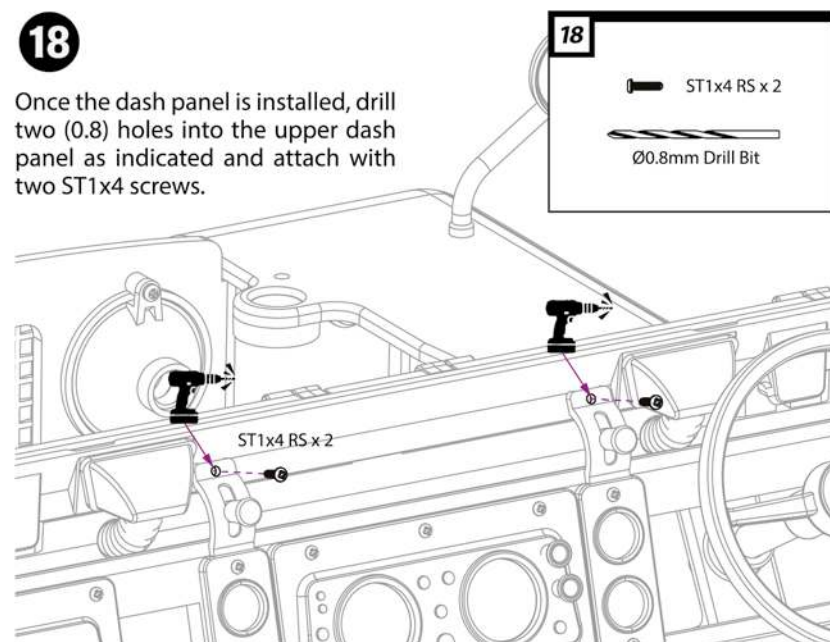

SOLID PANEL

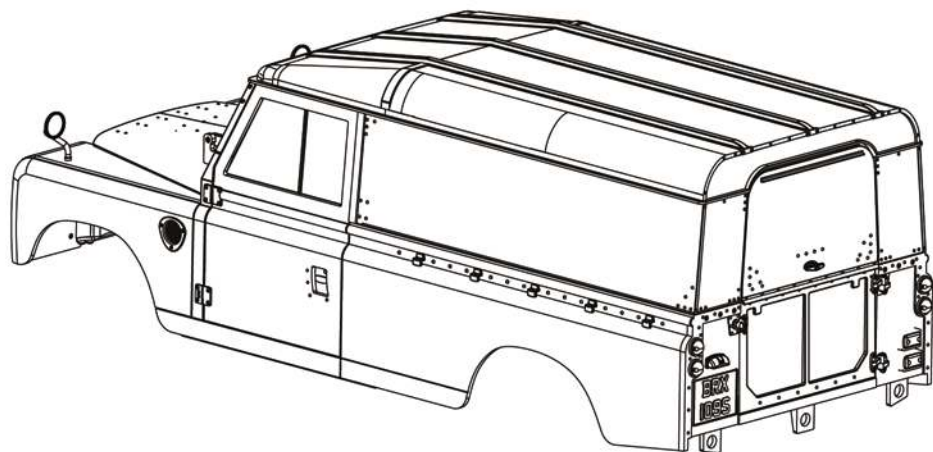

REAR WINDOW

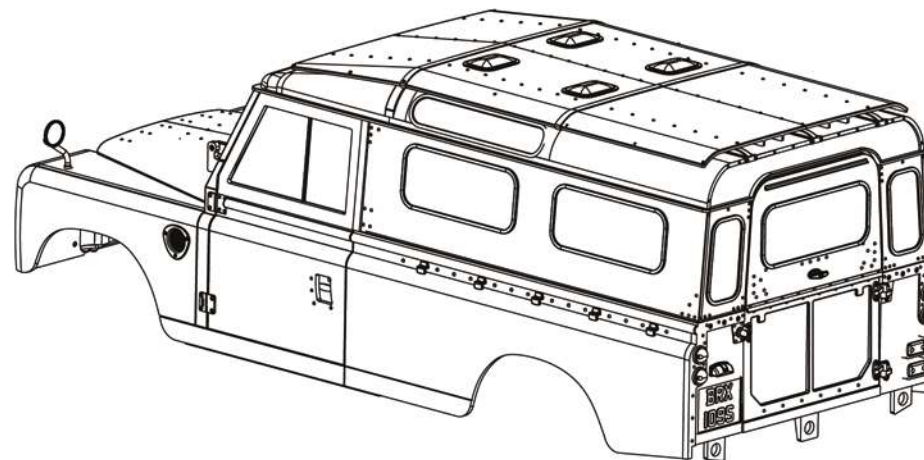

CHOOSE THE ROOF STYLE YOU WANT TO BUILD

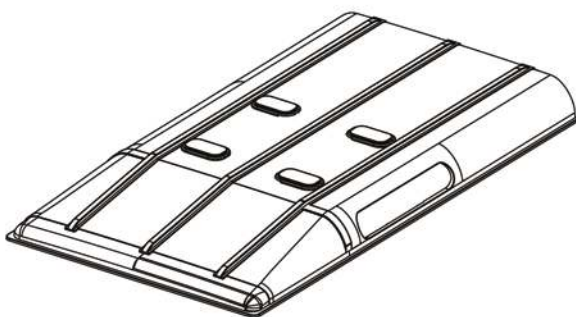

VENTED ROOF

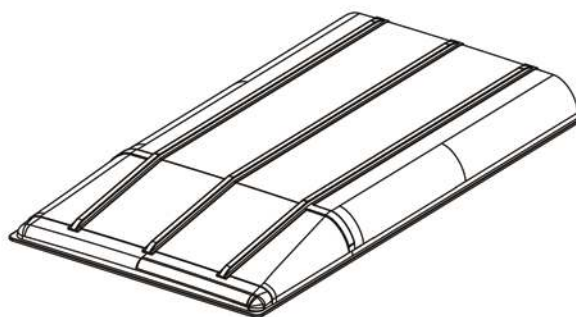

FLUSH ROOF

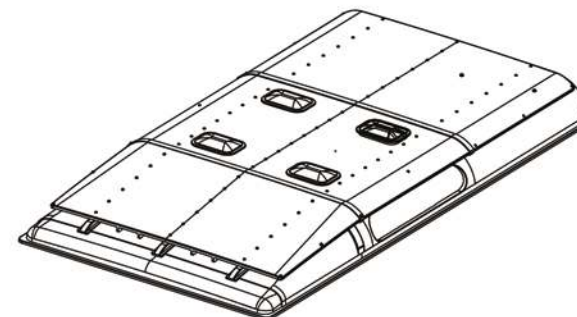

TROPICAL ROOF

VENTED ROOF

19

Glue the parts to the roof panel as indicated by the part letters. Attach tropical windows from the outside. Ensure correct placement of the two rear top door hinge mounts, as shown in the zoomed-in graphic.

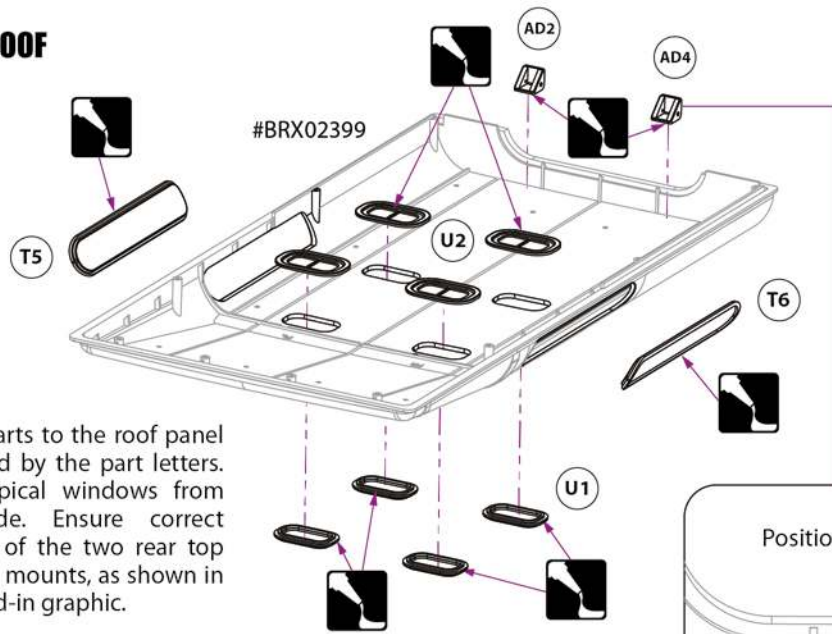

TROPICAL ROOF

19

ST1.5x5 RS x 14

Ø1.7mm Drill Bit

Positions of the rear top door hinge mounts



FLUSH ROOF

19

Glue the parts to the roof panel as indicated by the part letters. Attach the two blanking panels from the inside. Ensure correct placement of the two rear top door hinge mounts, as shown in the zoomed-in graphic.

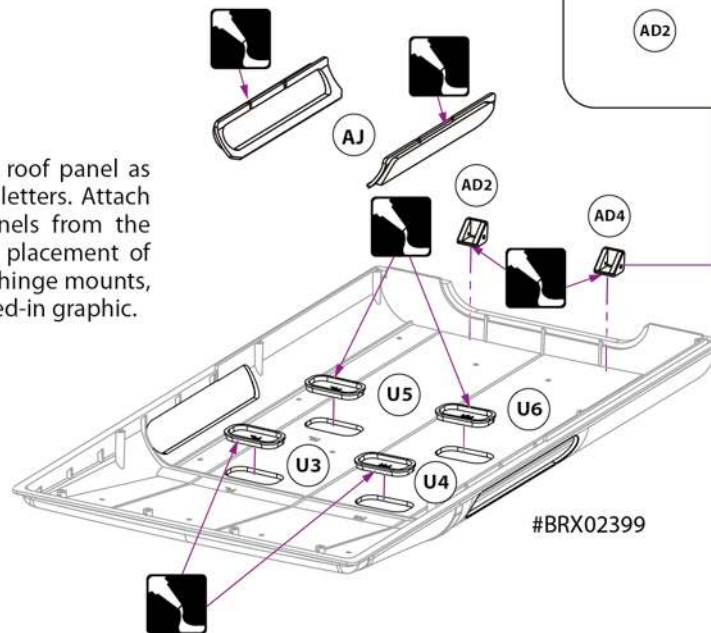

19

Glue the parts to the roof panel as indicated by the part letters. Attach tropical windows from the outside. Ensure correct placement of the two rear top door hinge mounts, as shown in the zoomed-in graphic.

Drill ten 1.7mm holes into the roof, indicated by the divots (see graphic). Attach the tropical roof with fourteen ST1.5x5 screws.

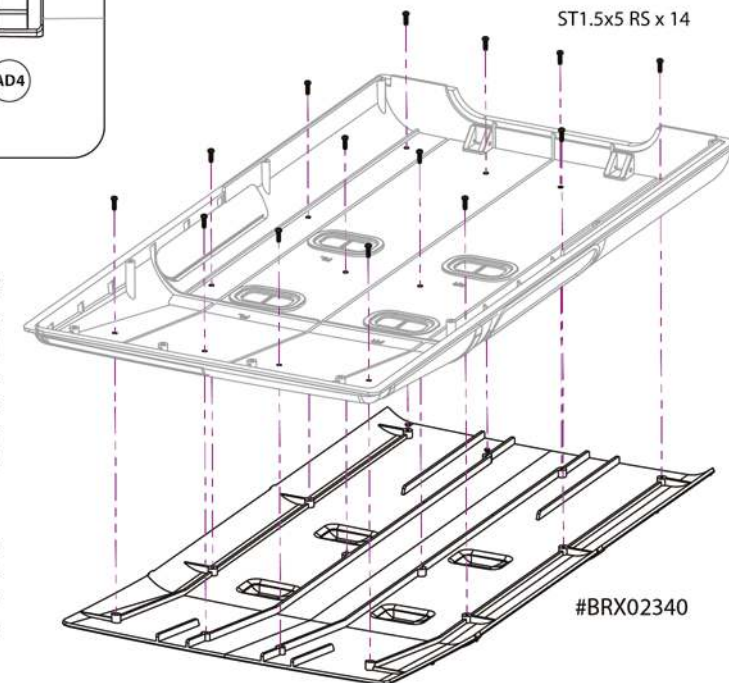
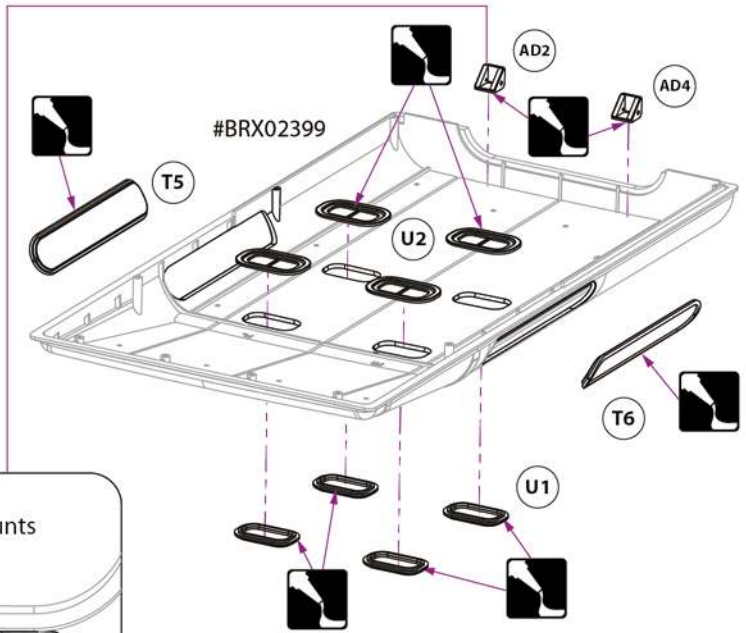

SOLID PANEL

20

Glue the blanking panel to the rear top door from the inside. For best results, use body filler to smooth out the panel gaps.

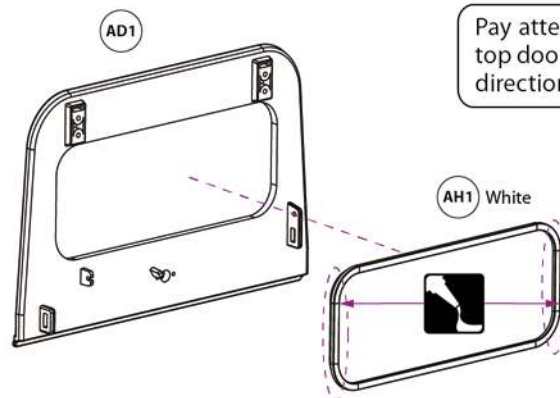

Pay attention to the rear top door and side panels directions.

REAR WINDOW

20

Glue the rear window onto the rear top door from the outside.

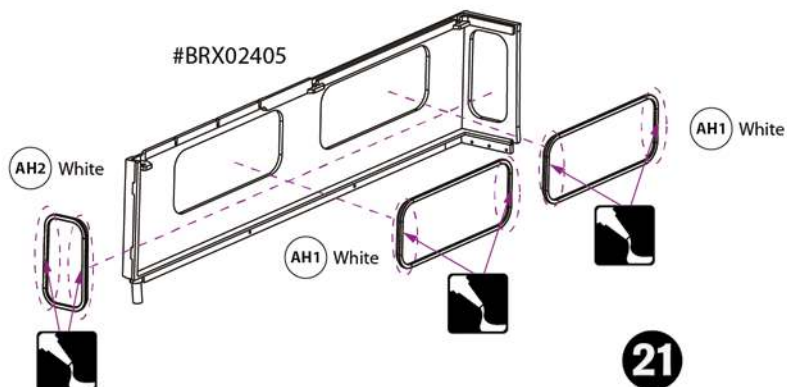
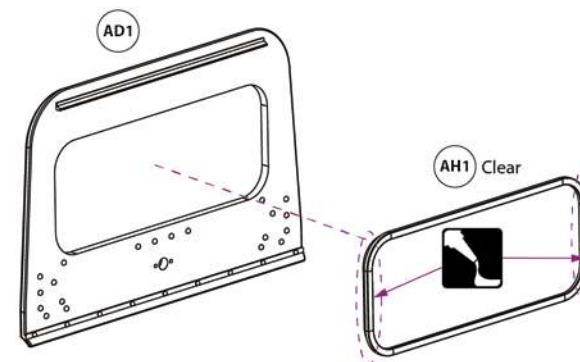

21

Glue the three blanking panels onto the rear side body panel from the inside. For best results, use body filler to smooth out the panel gaps. (x2)

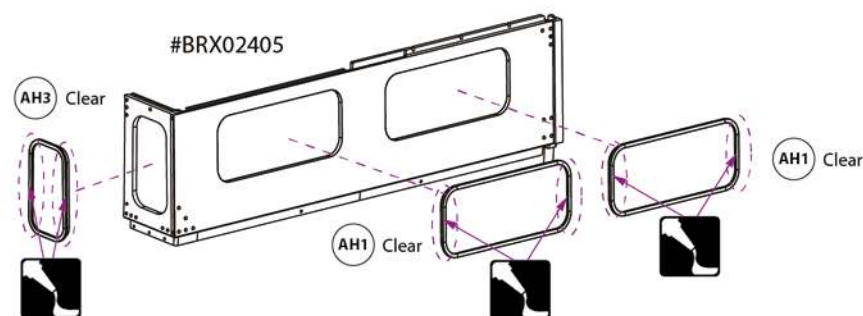
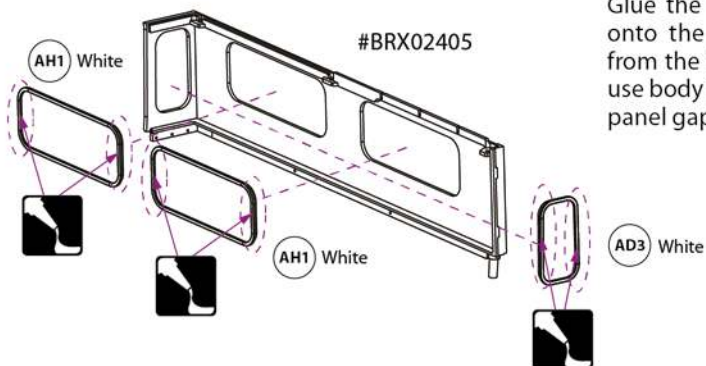

21

Glue the side and rear windows onto the rear side body panel from the outside. (x2)

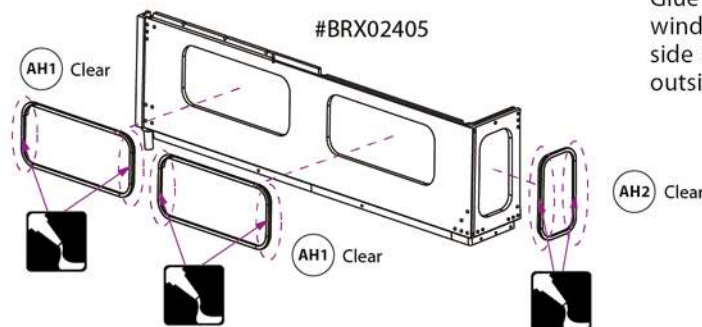

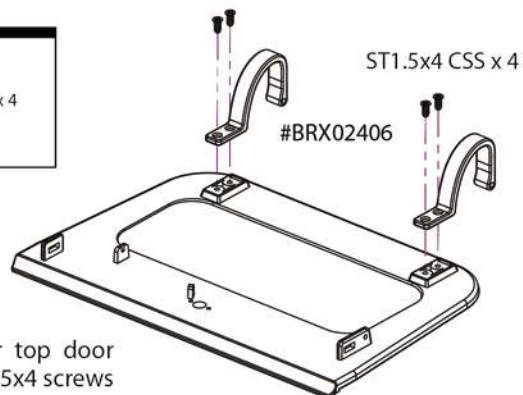
**22**

Attach the two rear top door hinges with four ST1.5x4 screws to the rear top door.

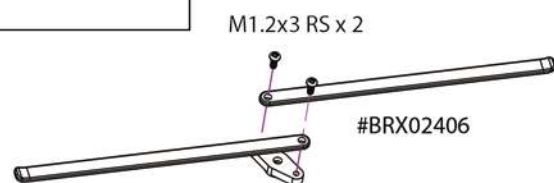
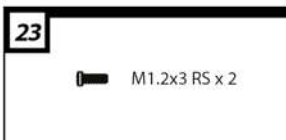
**23**

Assemble the rear top door latch mechanism with two M1.2x3 screws.

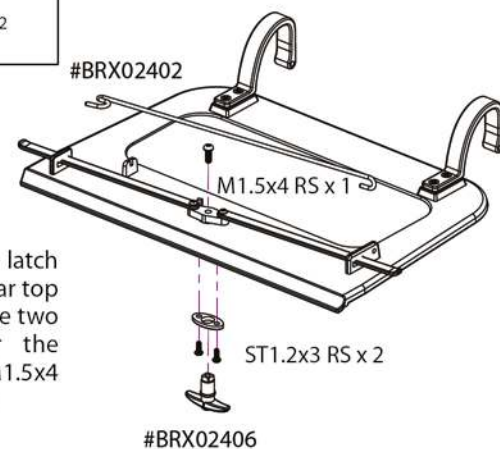
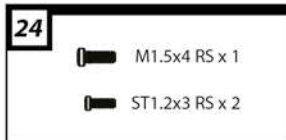
**24**

Carefully insert the latch mechanism to the rear top door as indicated. Use two ST1.2x3 screws for the mount and one M1.5x4 screw for the handle.

Use the 0.80 drill bit to drill out these two holes.

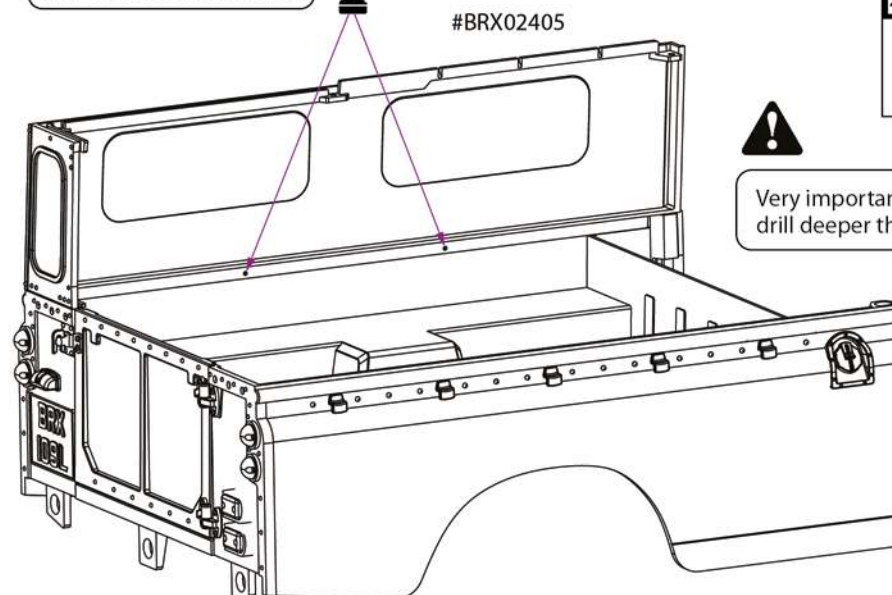
**25**

Insert the rear side panels into the rear bed and drill four 0.8mm holes into the rear bed as indicated.



Very important not to drill deeper than 5mm.

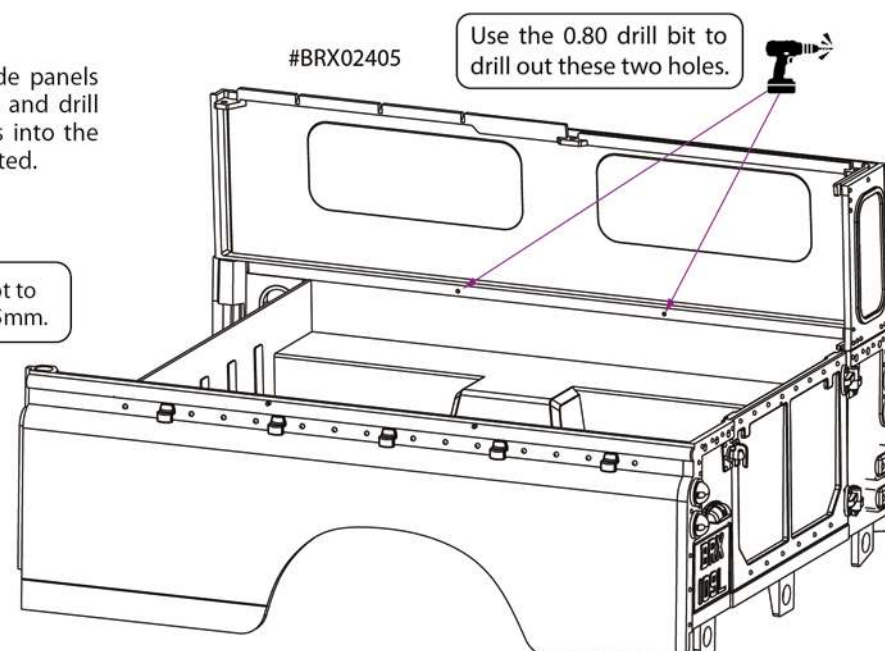

26

ST2x8 RS x 6

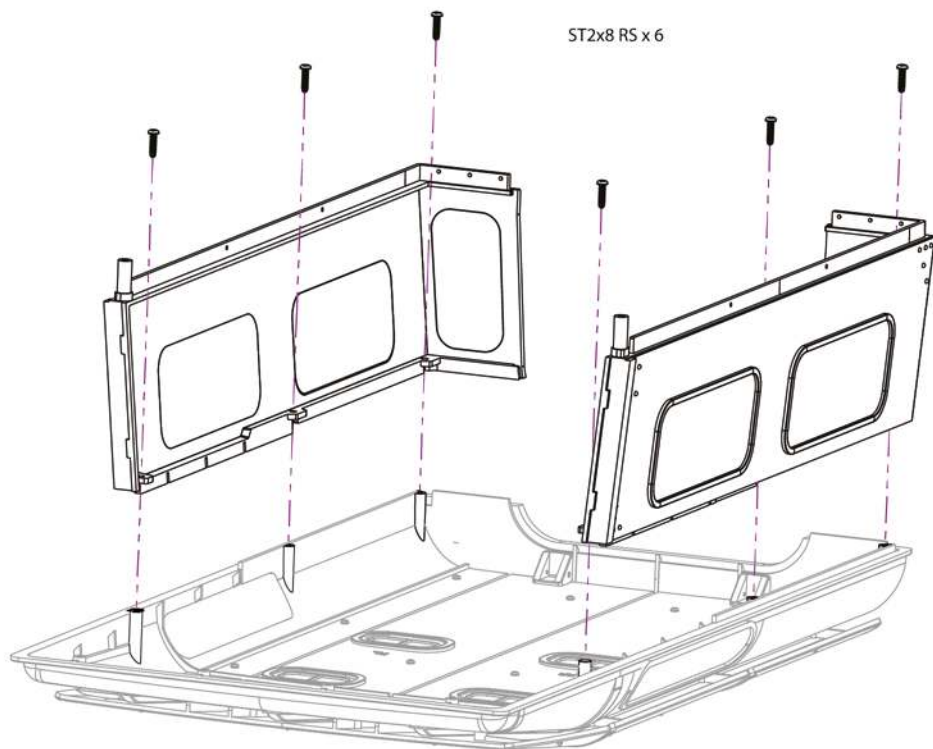

26 Attach the rear left and right side panels to the roof panel with six ST2x8 screws.

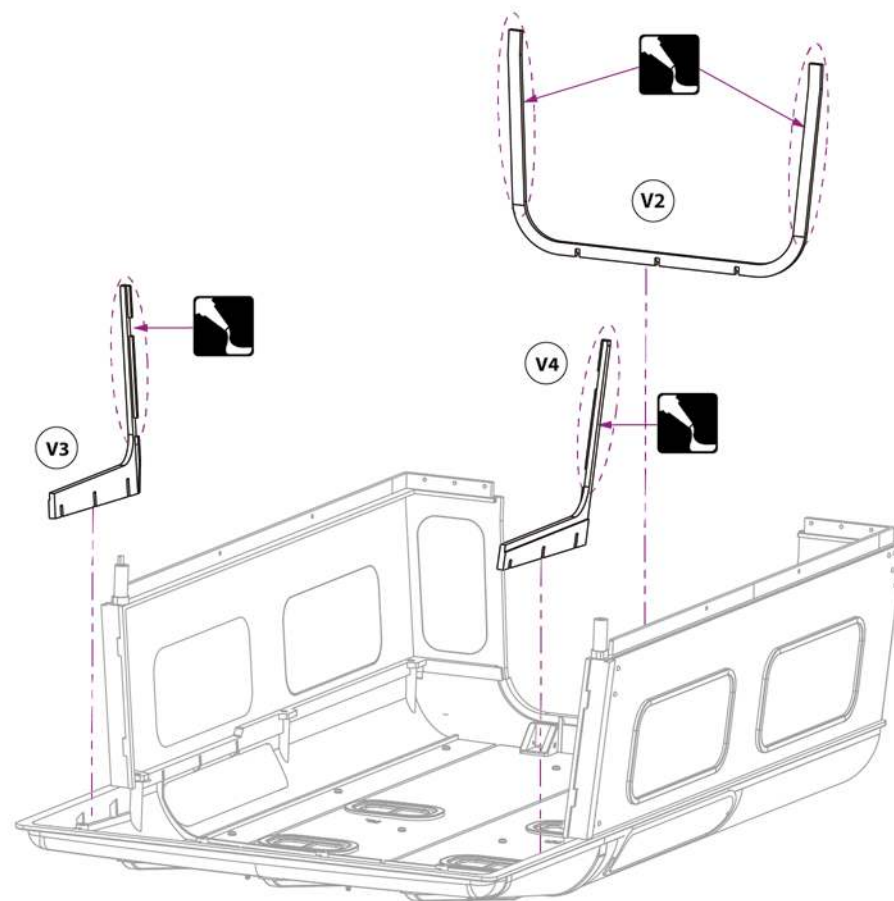

27 Glue the three body pieces to the hardtop as shown. Apply glue only to the circled areas where they bond to the panels.

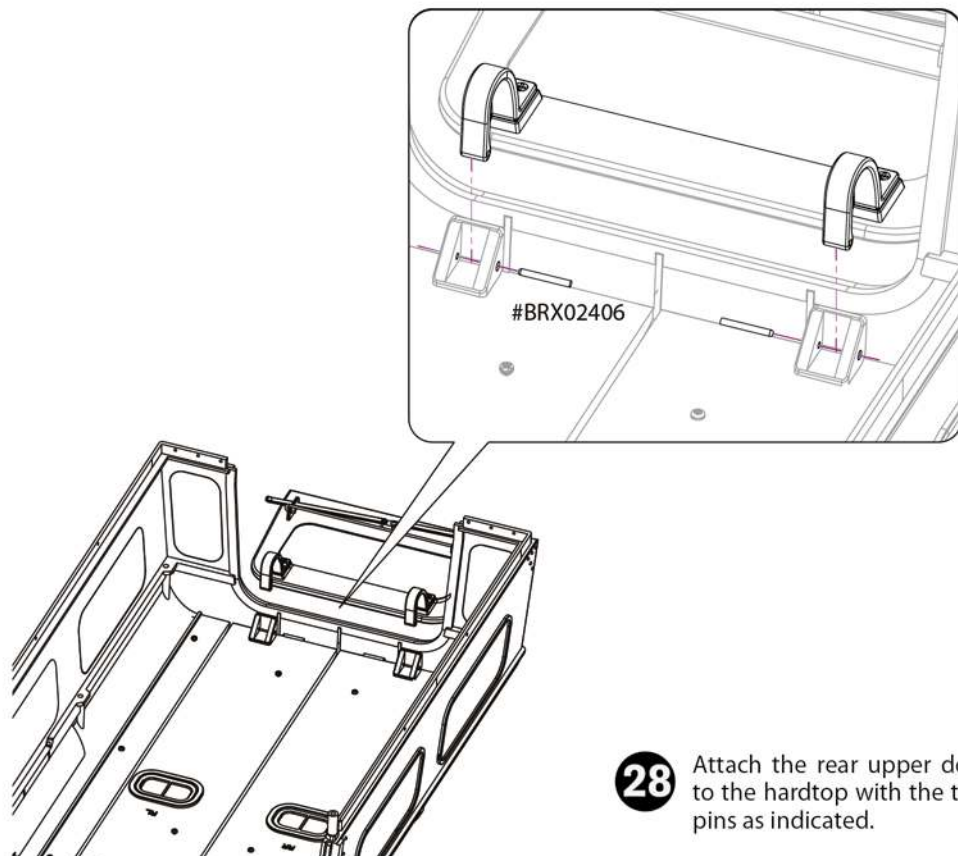

28 Attach the rear upper door to the hardtop with the two pins as indicated.

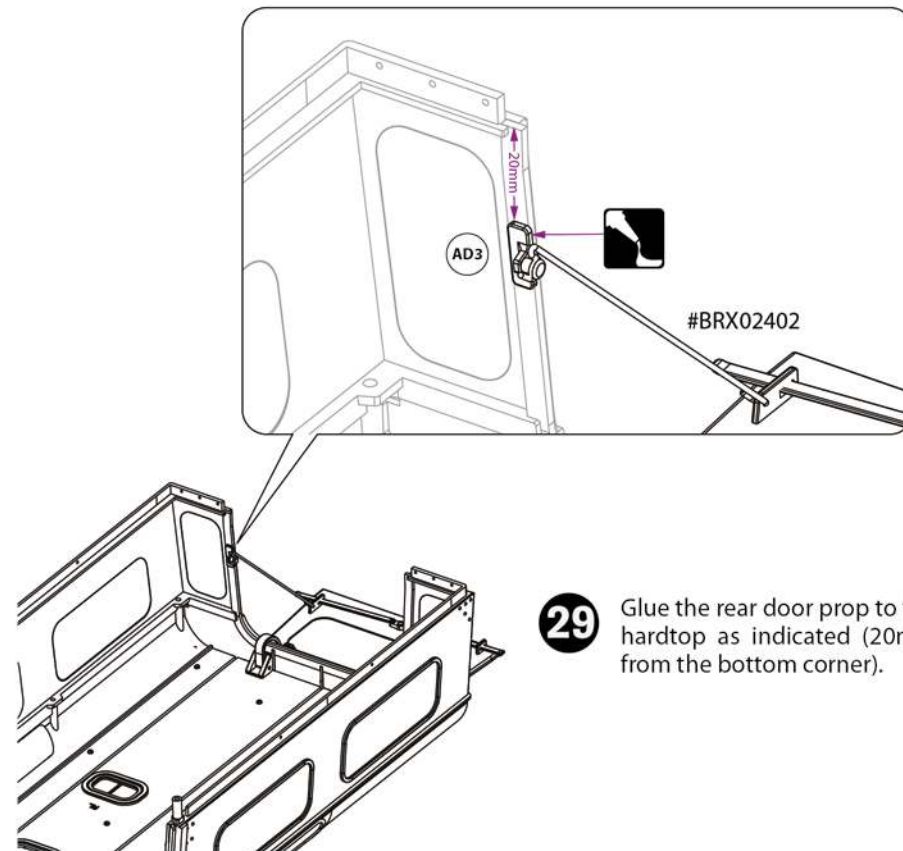

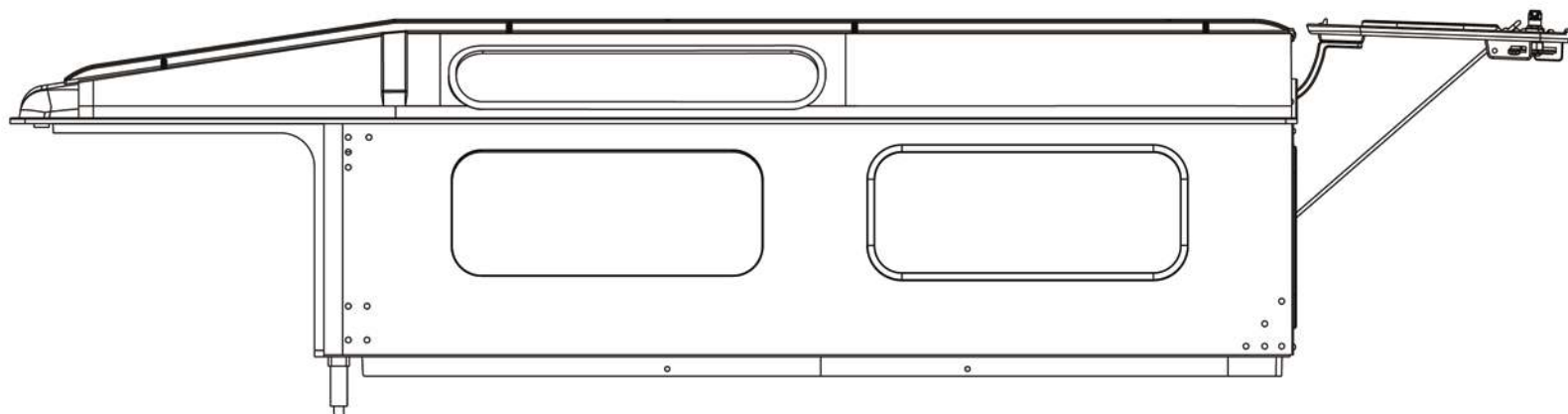

29 Glue the rear door prop to the hardtop as indicated (20mm from the bottom corner).



30 Attach the hardtop to the rear main bed with two ST2.6x10 screws and six ST1.5x4 screws.

30

-  ST1.5x4 RS x 6
-  ST2.6x10 RS x 2

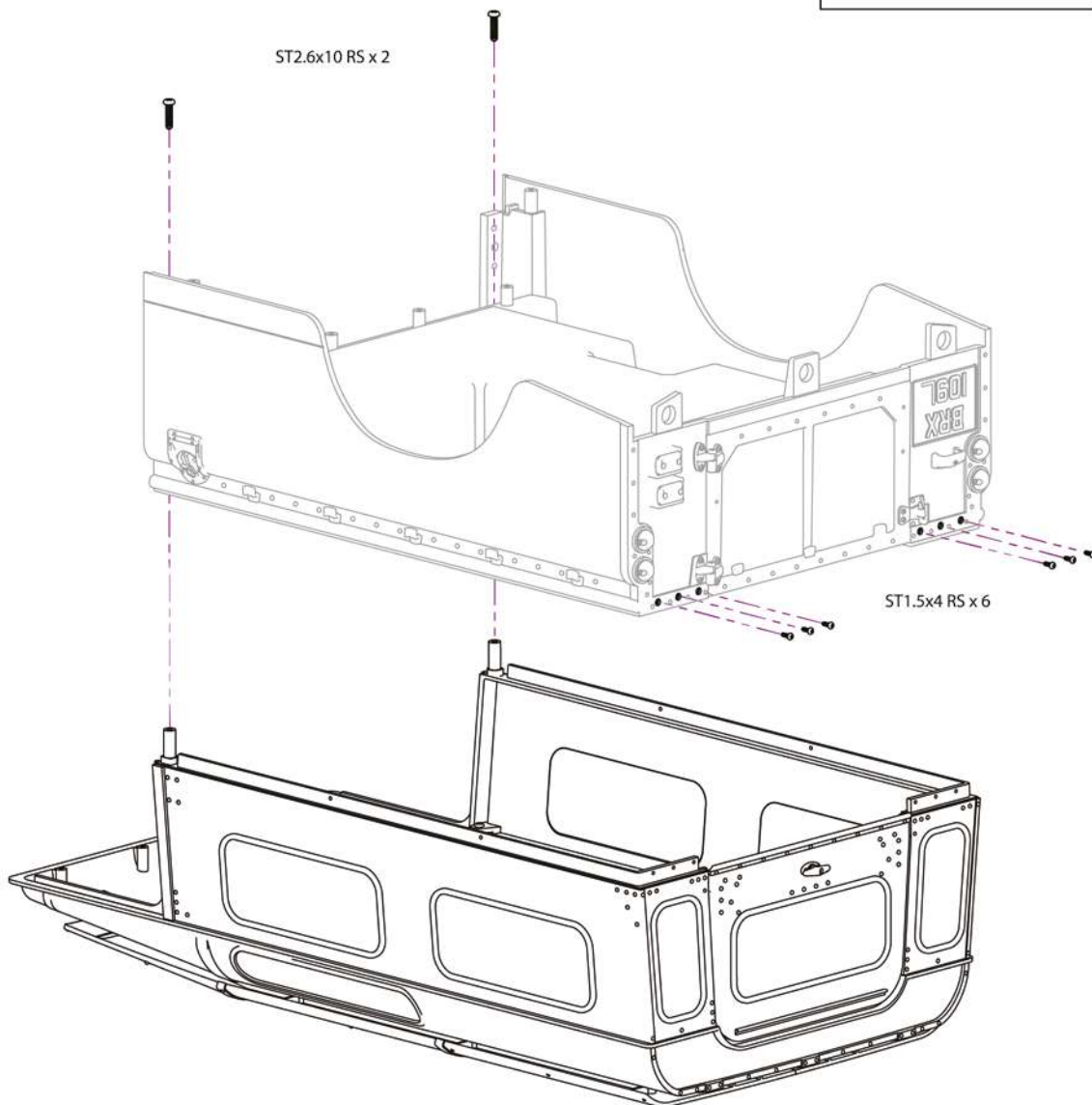

31

-  ST1x4 RS x 4

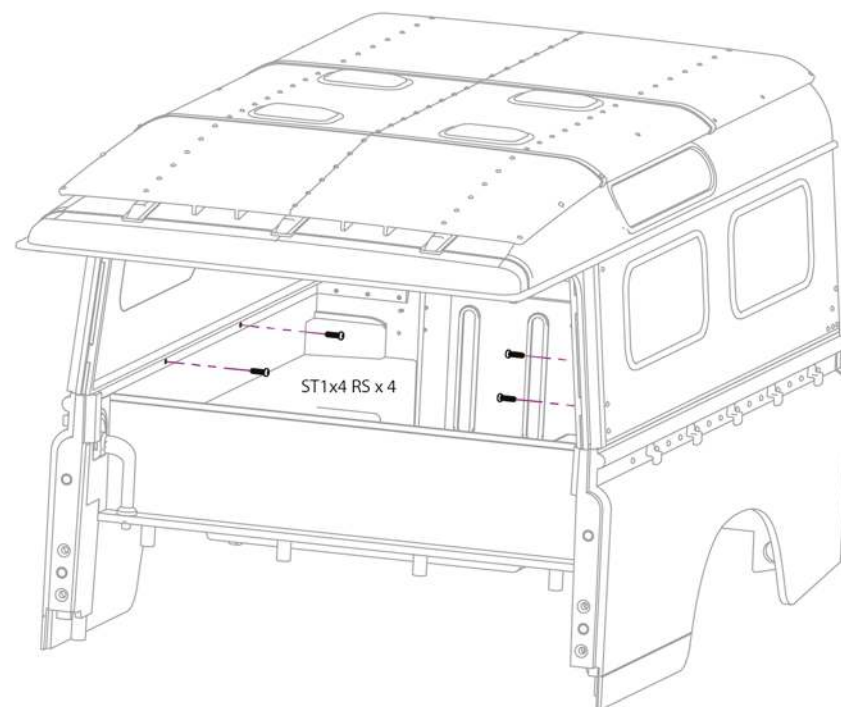

31 Install four ST1x4 screws to the four holes you've pre-drilled earlier as indicated.

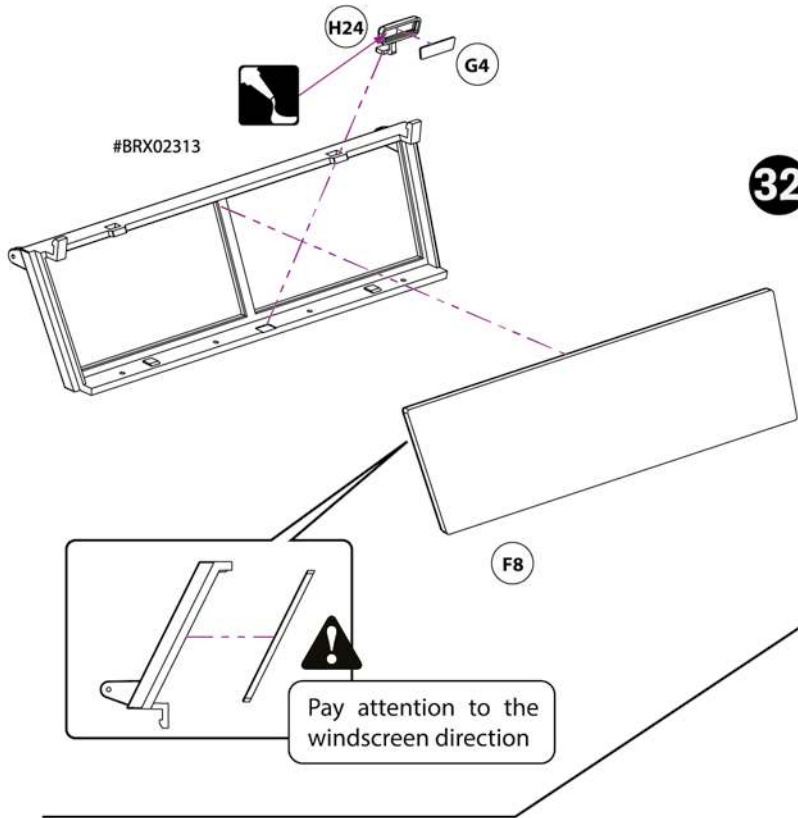

32 Clip the windscreen into the windscreen frame and glue the interior mirror onto the indicated location.



33 Attach the windscreen frame to the hardtop with four ST2x6 screws.

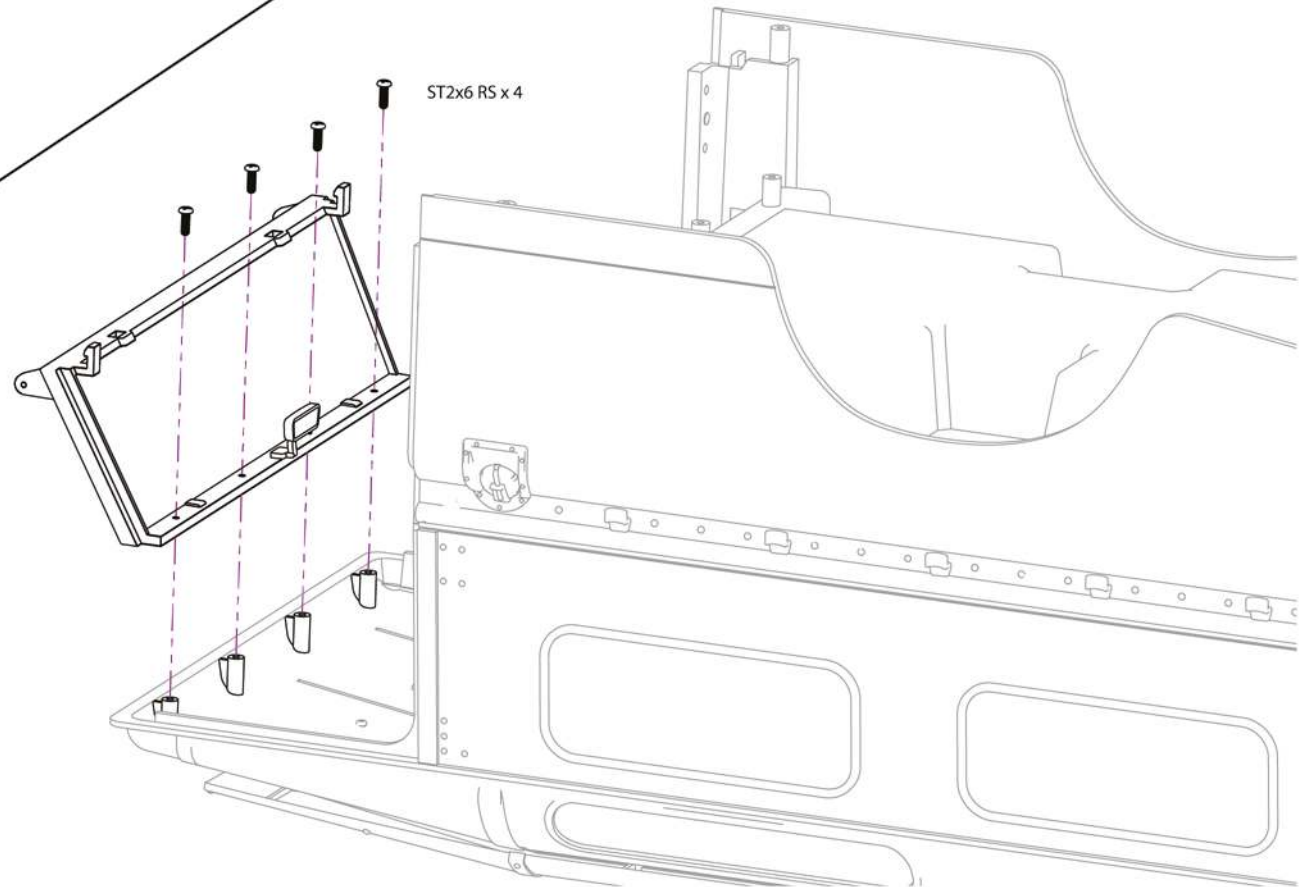

34

ST2x8 RS x 2

34

Line up the front main body with the interior floor and attach using two ST2x8 screws.

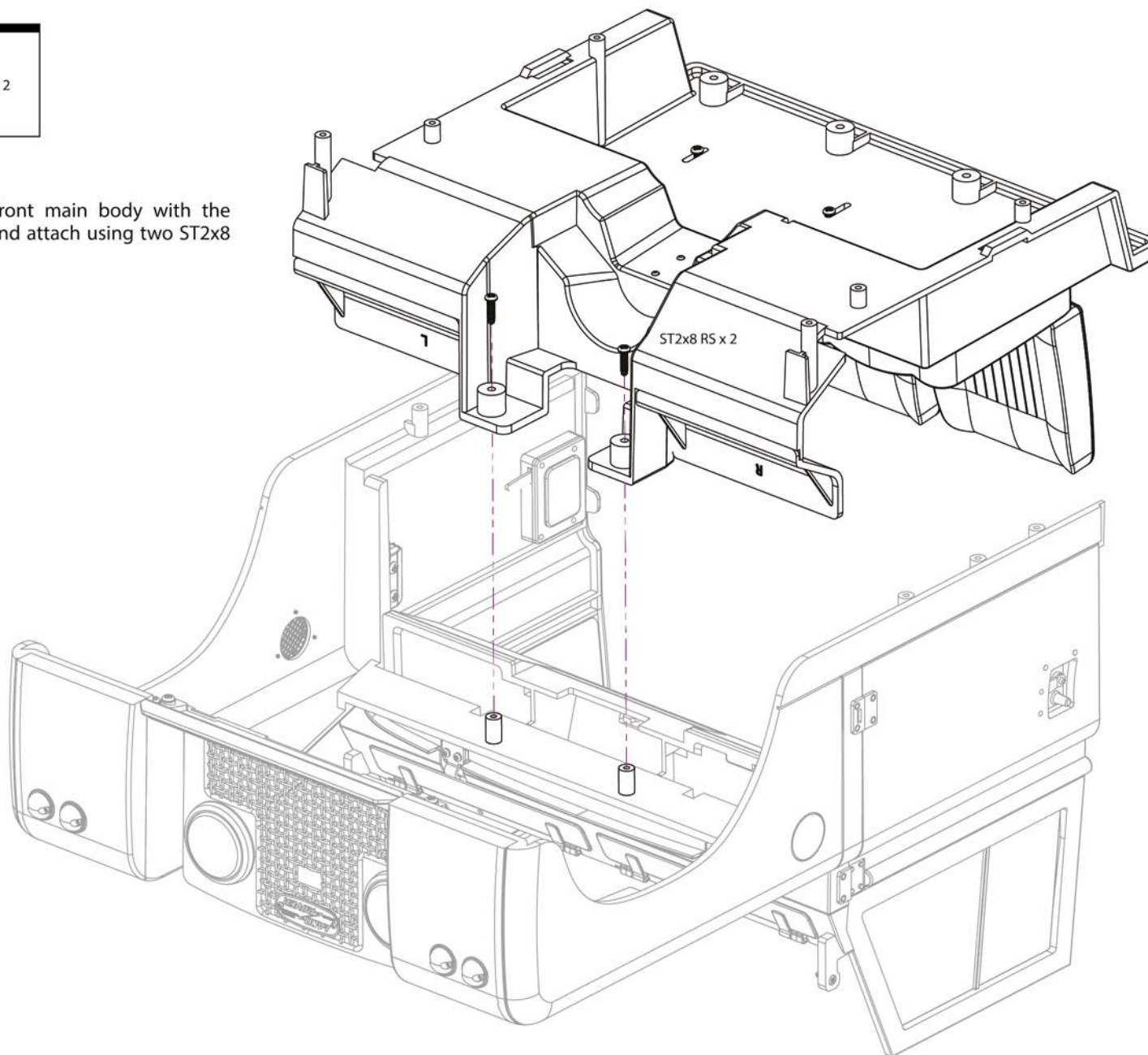

35

ST2x8 RS x 4

35

Line up the rear bed with hardtop to the front main body with the interior and attach using four ST2x8 screws.

ST2x8 RS x 4

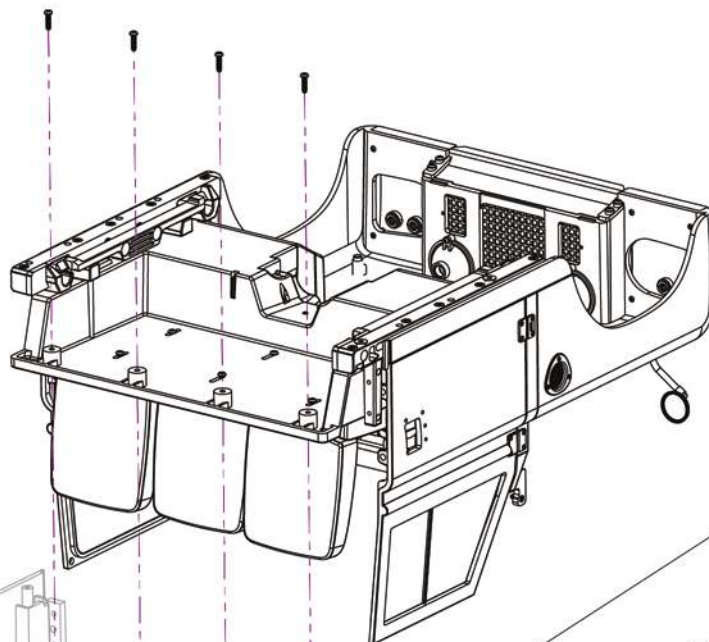

36

ST1.5x5 RS x 2

ST1.5x5 RS x 2

36

Attach the windscreen frame to the vent panel hinge mounts with two ST1.5x5 screws.

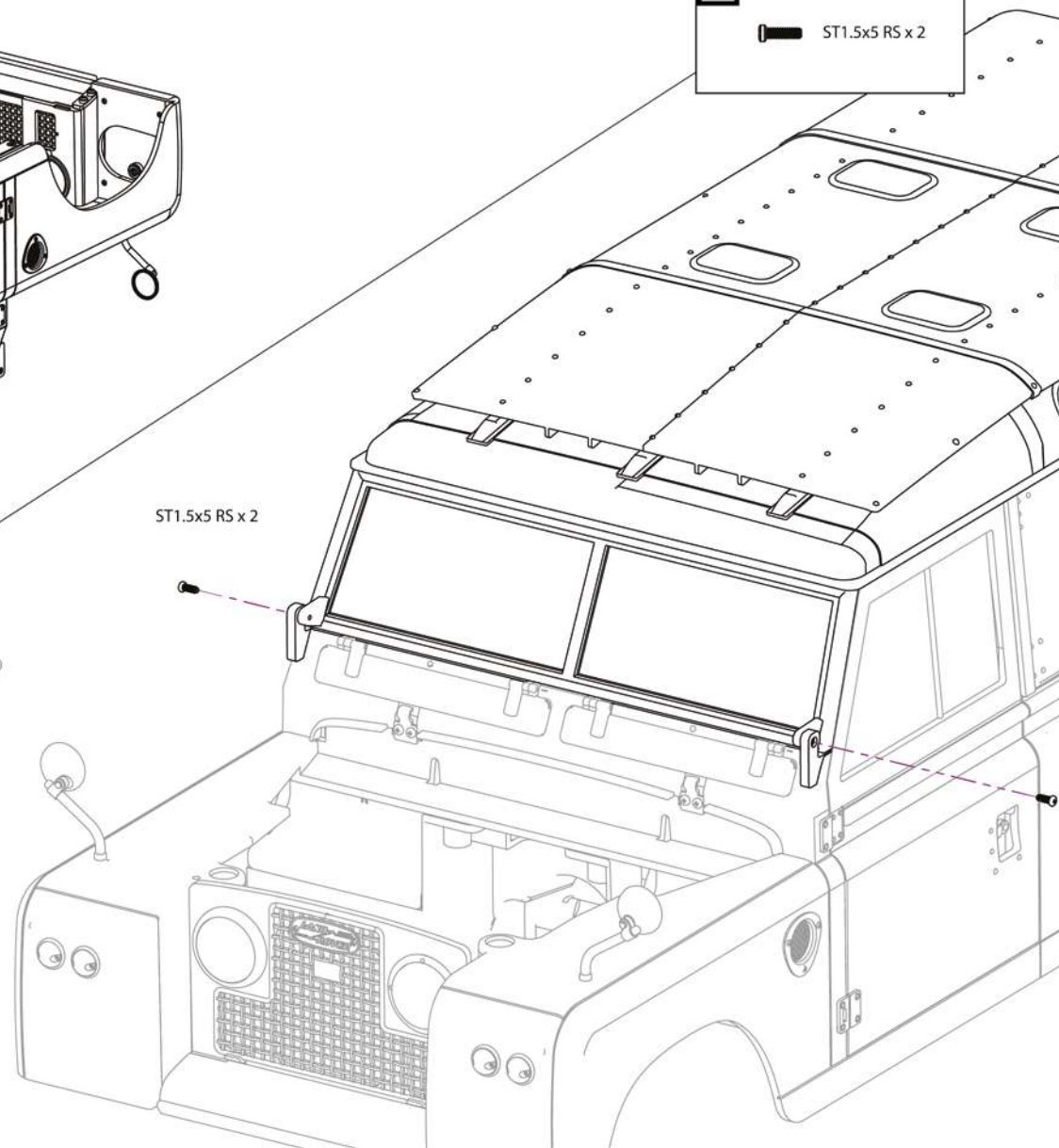

37

ST2x8 CSS x 10

ST2x8 CSS x 10

37

Install the two aluminum braces to the body using ten STCS2x8 screws to make sure everything is locked into position.

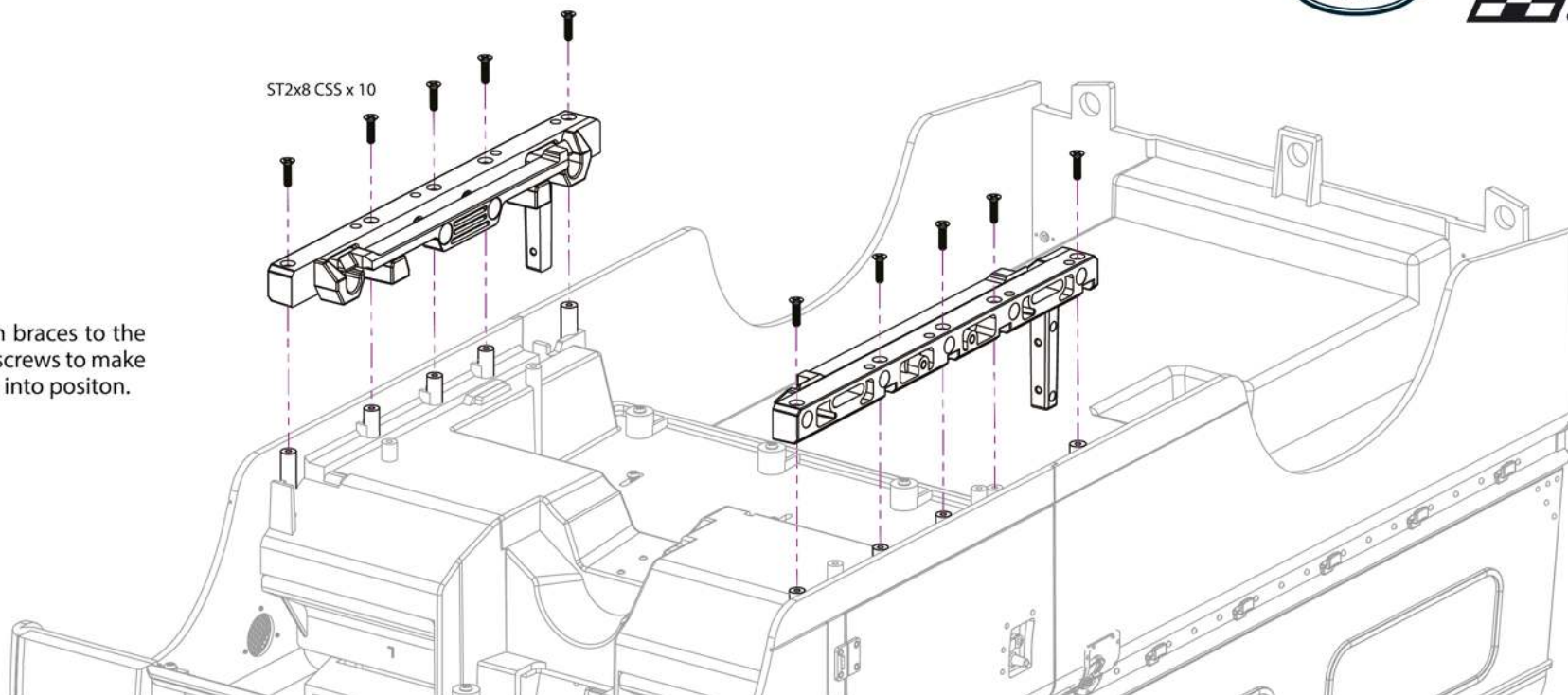

38

M2x8 CSS x 4

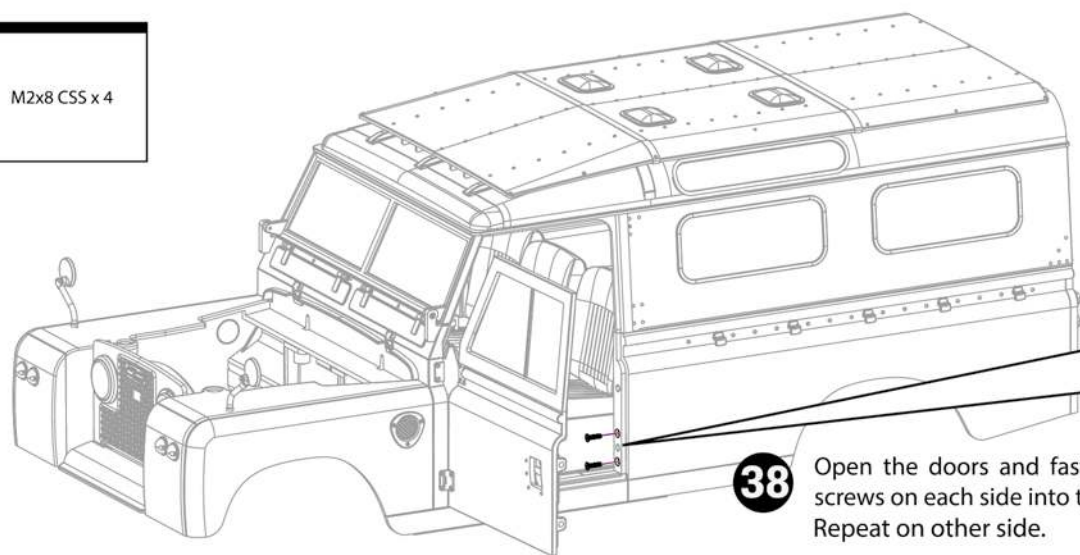

38

Open the doors and fasten two M2x8CS screws on each side into the aluminum brace. Repeat on other side.

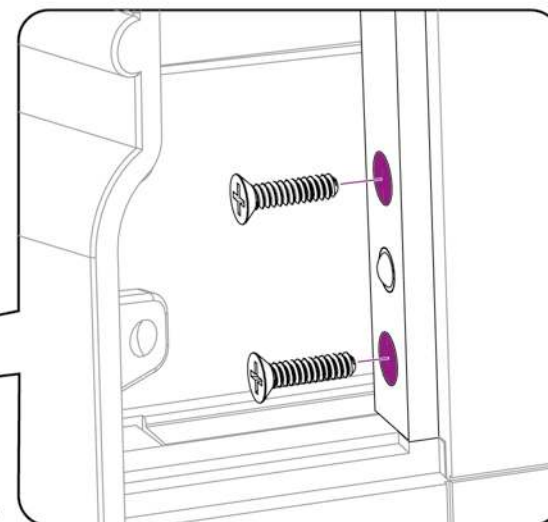

Use the two STCS3x6 screws to adjust the height of the bonnet and how tight they latch to the magnet.



Use the provided 1.0 mm drill bit to pre-drill the six hood hinge holes so the ST1.2x4 screws install smoothly. Keep the screw perfectly straight and tighten slowly.

ST1.2 x 4 RS x 6

L11

L10

#BRX02349

#BRX02401

ST3 x 6 CSS x 2

H12

H14



Do not tighten the screws all the way down. The head must not pass the dotted line, otherwise the bonnet can be damaged.

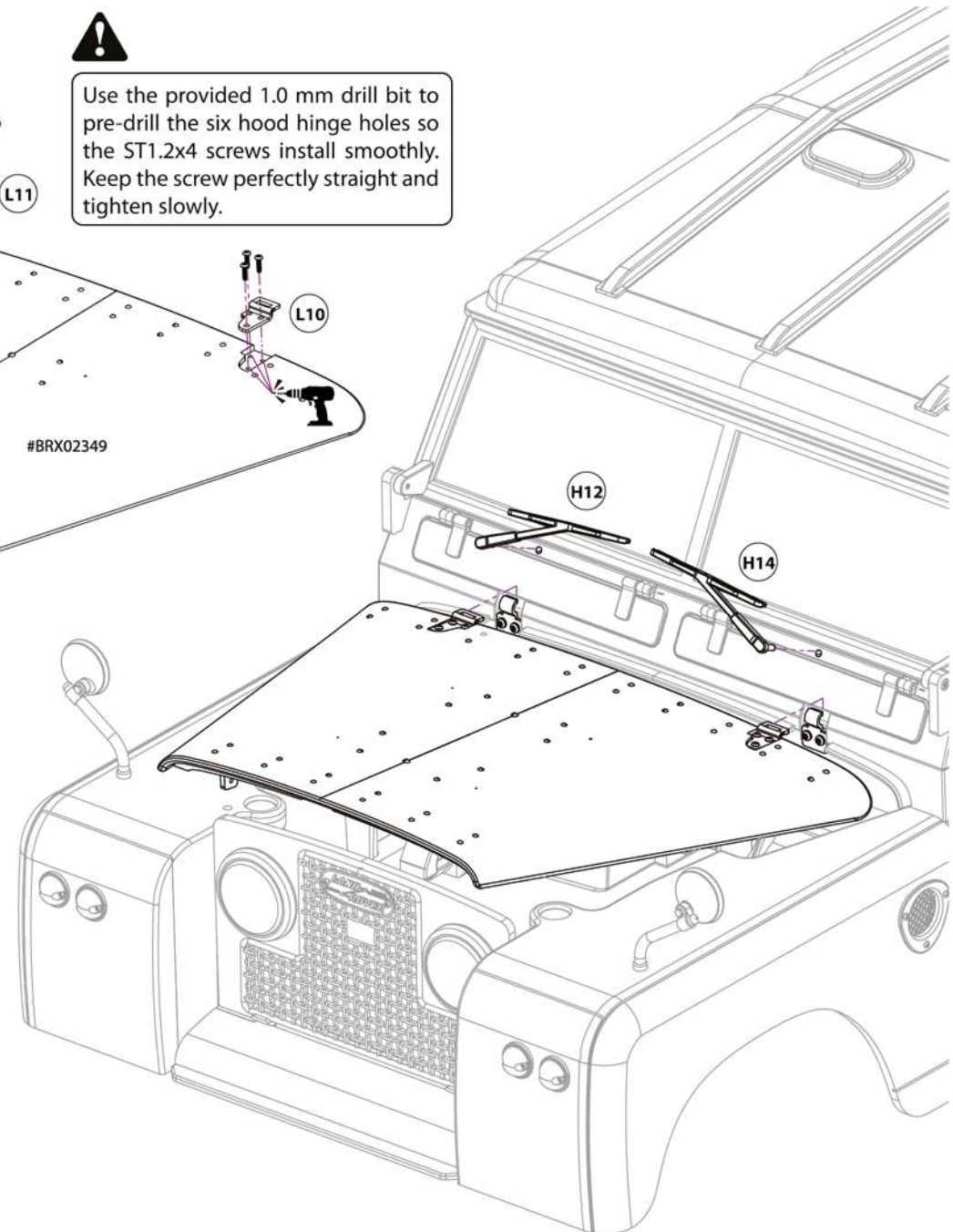
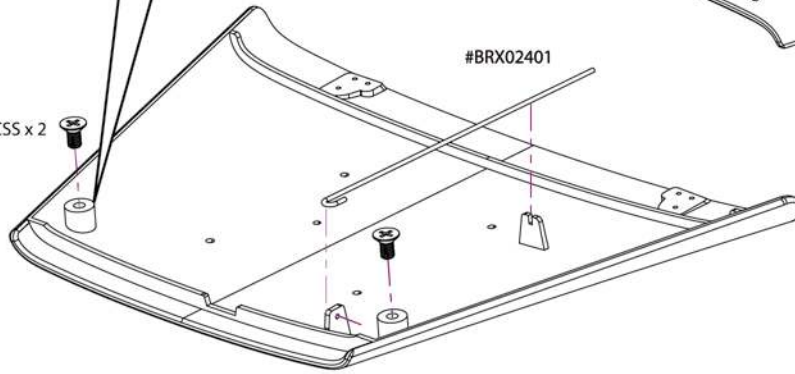
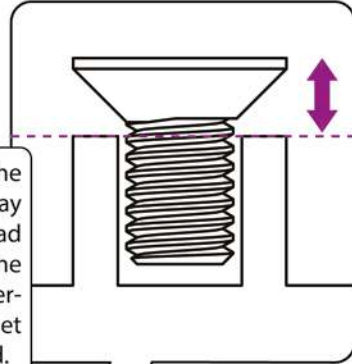

39

ST1.2 x 4 RS x 6

ST3 x 6 CSS x 2

Ø1.0mm Drill Bit

39

Attach the left and right bonnet hinge to the bonnet with six ST1.2x4 screws and two STCS3x6 screws into the bonnet. Attach the windscreen wipers.

40 Insert the blanking plate to the front chassis crossmember. It should snap into place. Use double-sided tape to attach the license plate to the license plate mount, and the mount to the bumper.

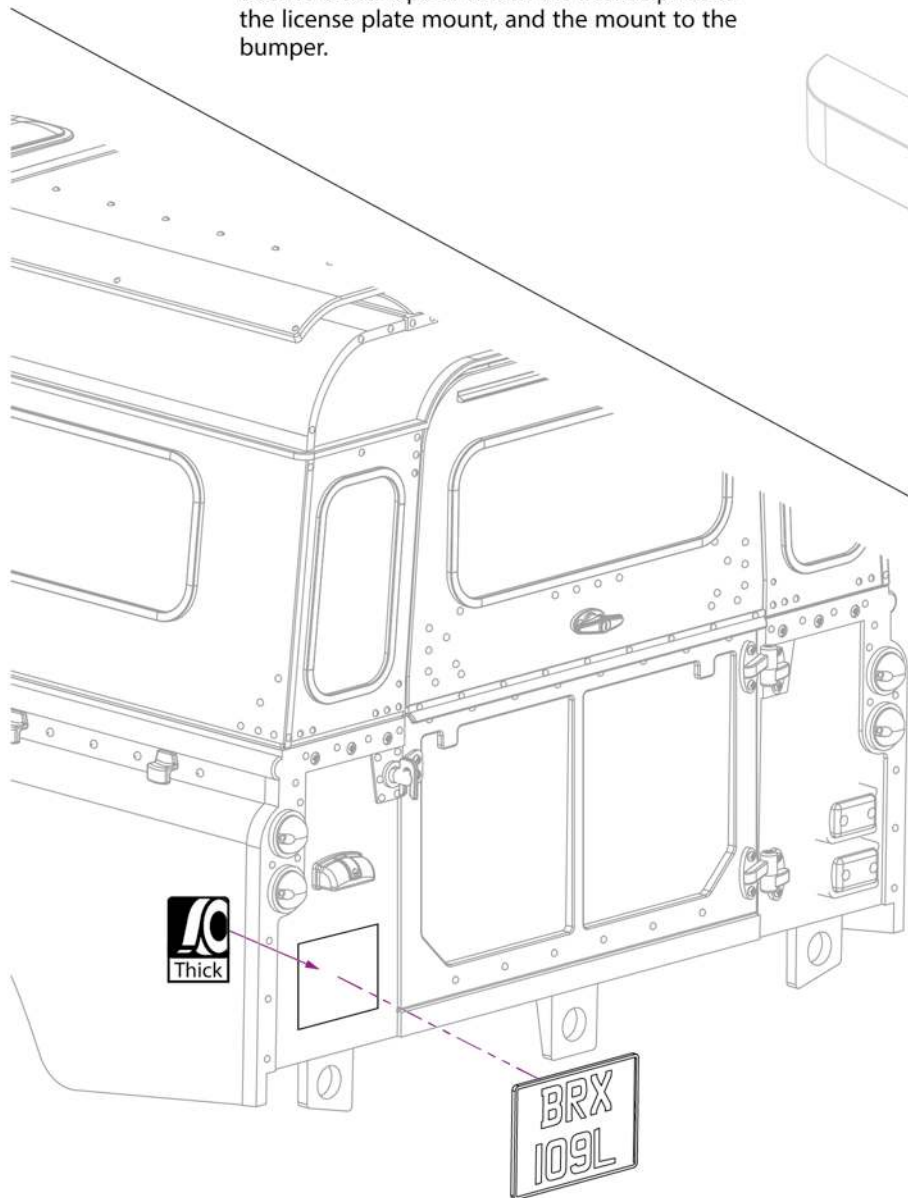
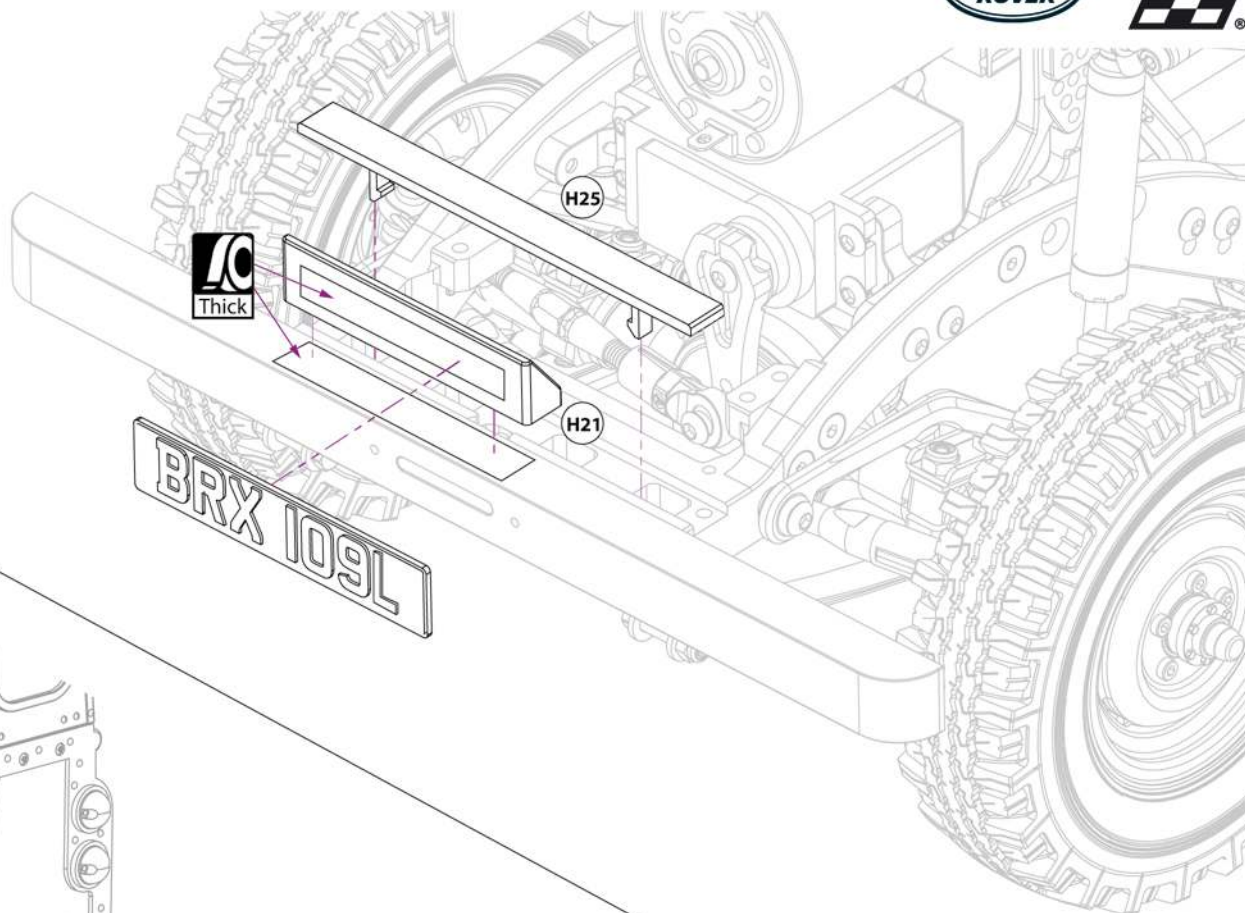

41 Use double-sided tape to attach the rear license plate onto the body below the license plate light.

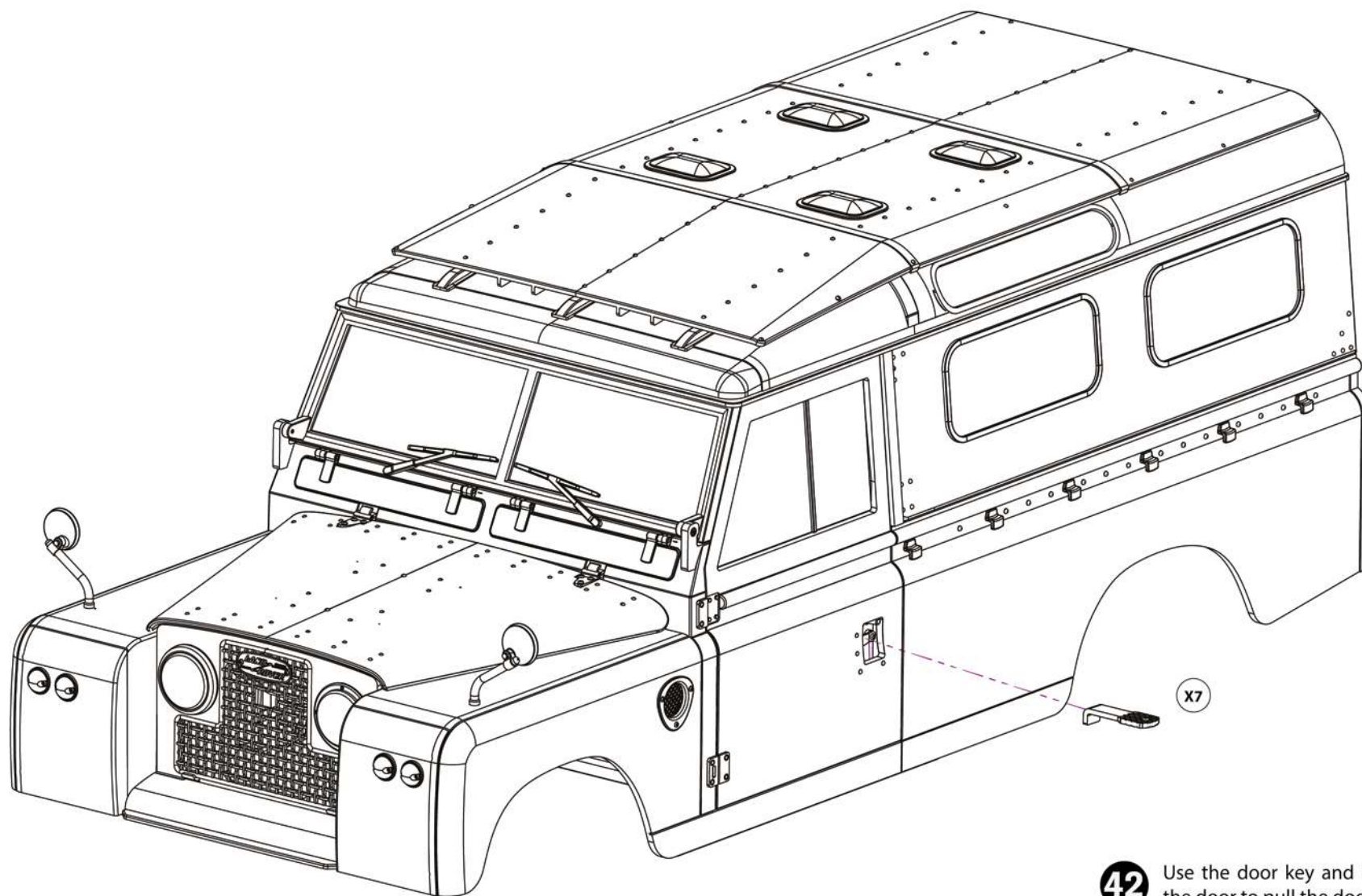
**COMPLETED**

- 42** Use the door key and hook it onto the door to pull the door open.

Continue on this page for Convertible build.



PICK YOUR SIDE MIRROR LOCATION

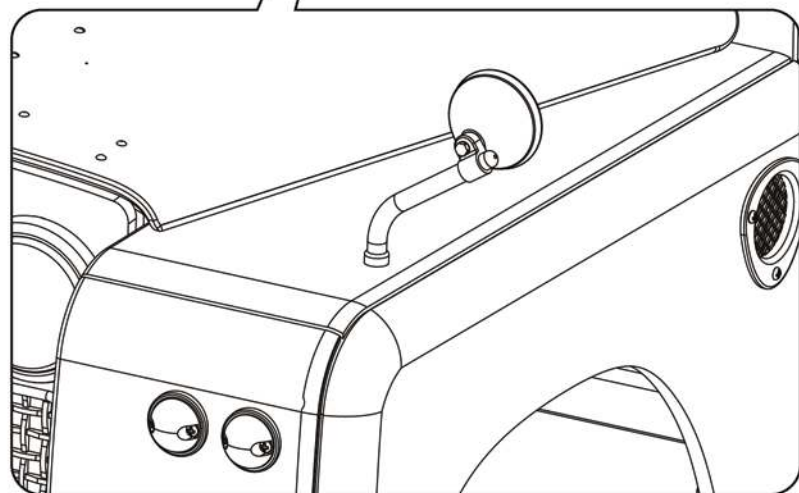
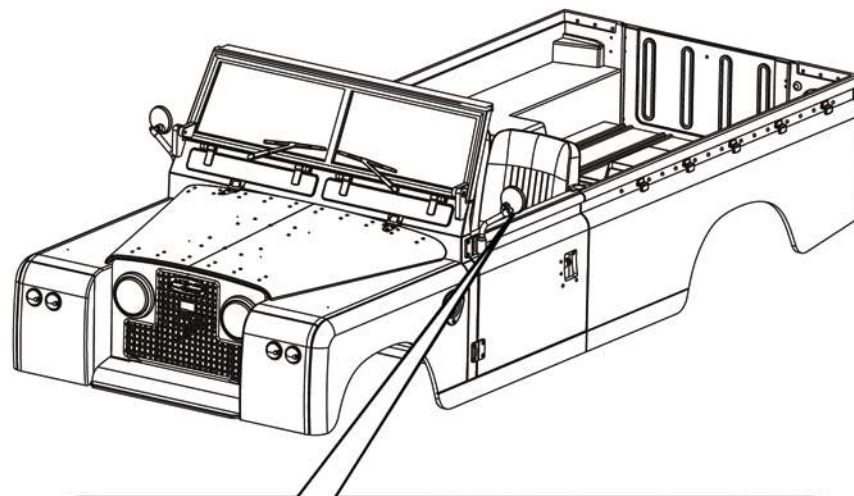
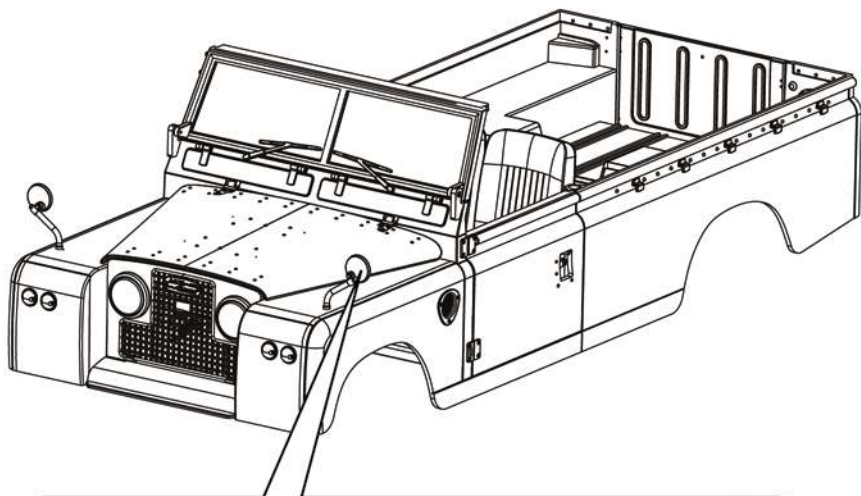

FENDER MIRRORS

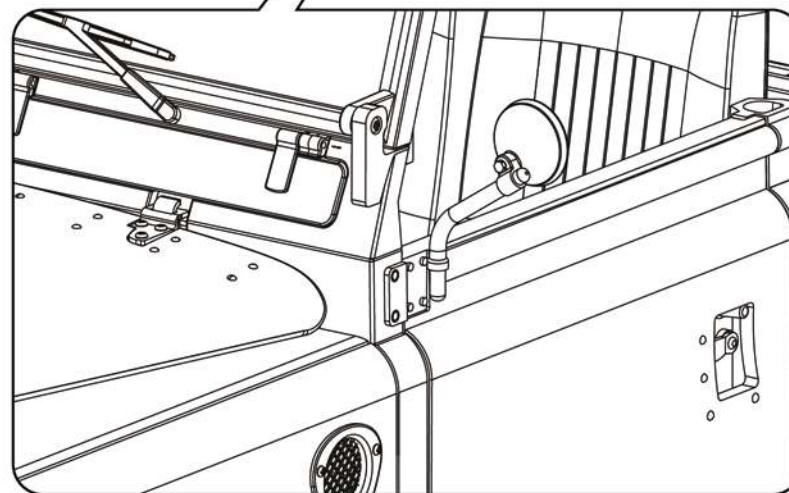

DOOR MIRRORS

FENDER MIRRORS

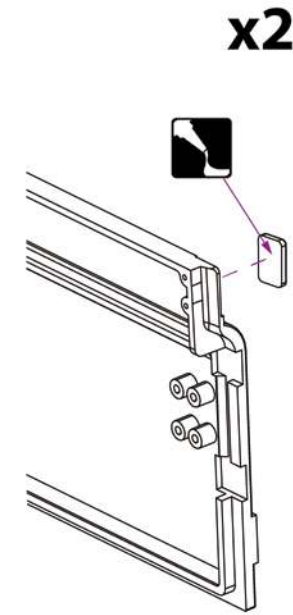
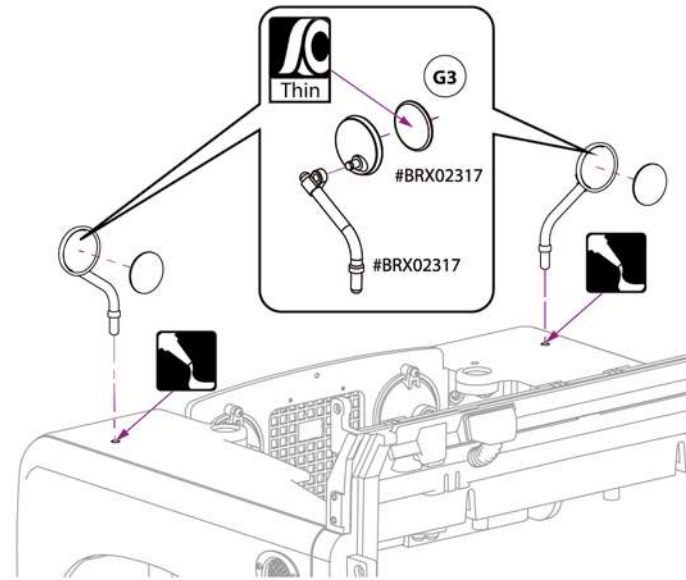
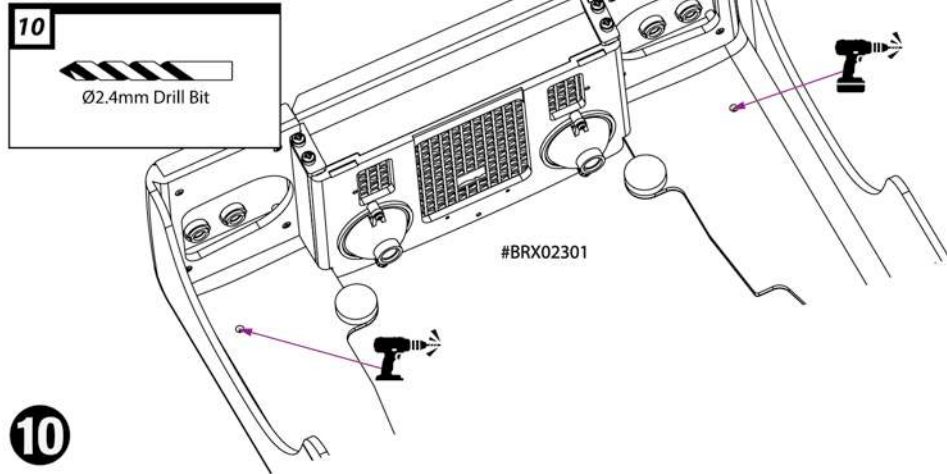

10

Drill two 2.4mm holes into the front main body from underneath as indicated. Use the provided double-sided tape (thin) to stick the mirror plate to the rubber mirror head and push the head into the mirror arm. Push the mirror arm into the holes that you just drilled. Then glue from the bottom into position. Repeat on the other side. Also on the door, stick the door blanking plate on both doors.

DOOR MIRRORS



10

Use the provided double-sided tape (thin) to stick the mirror plate to the rubber mirror head and push the head into the mirror arm. Glue the mirror arm to the mirror arm holder. Next, glue the assembly to the mirror retaining plate, and then glue the whole assembly to the door. Repeat for the other side.

Insert the inner and outer door handles into the door and door lock plate and glue into position. Attach door hinge using four ST2x5 screws. Repeat on the other side.

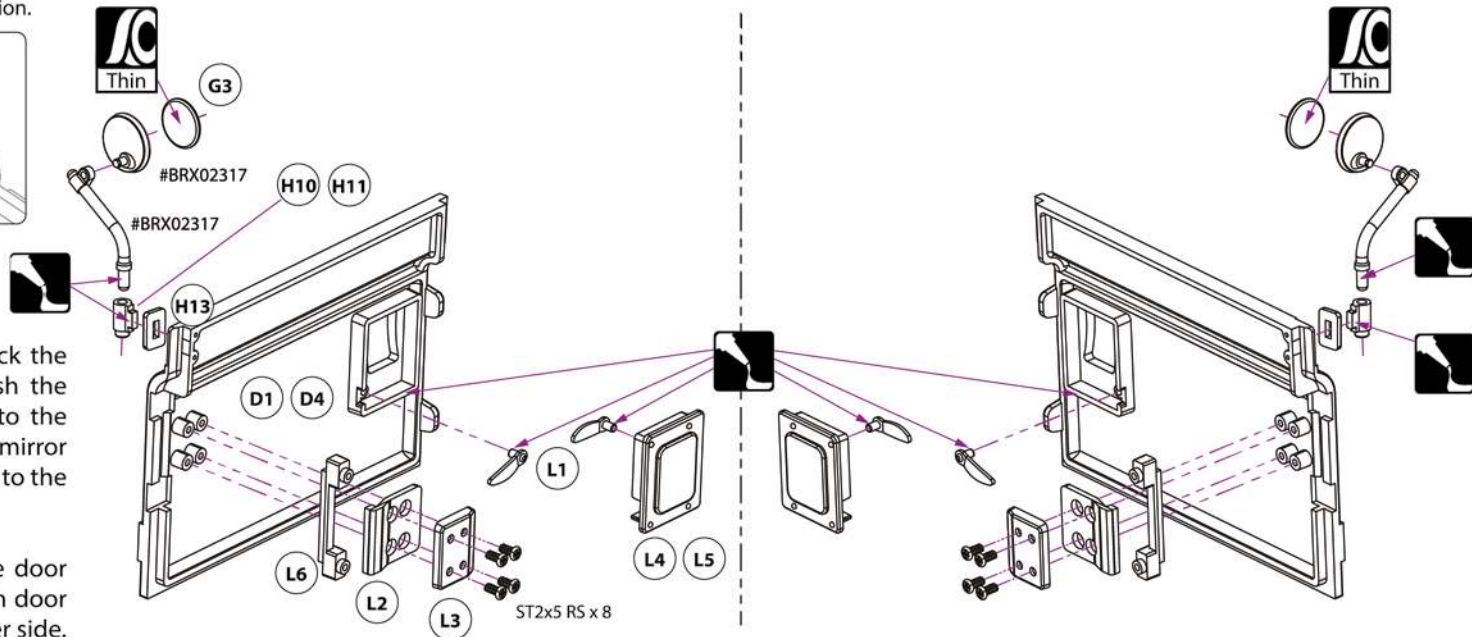

11

Attach the left and right doors to the front main body with four ST2x6 screws.

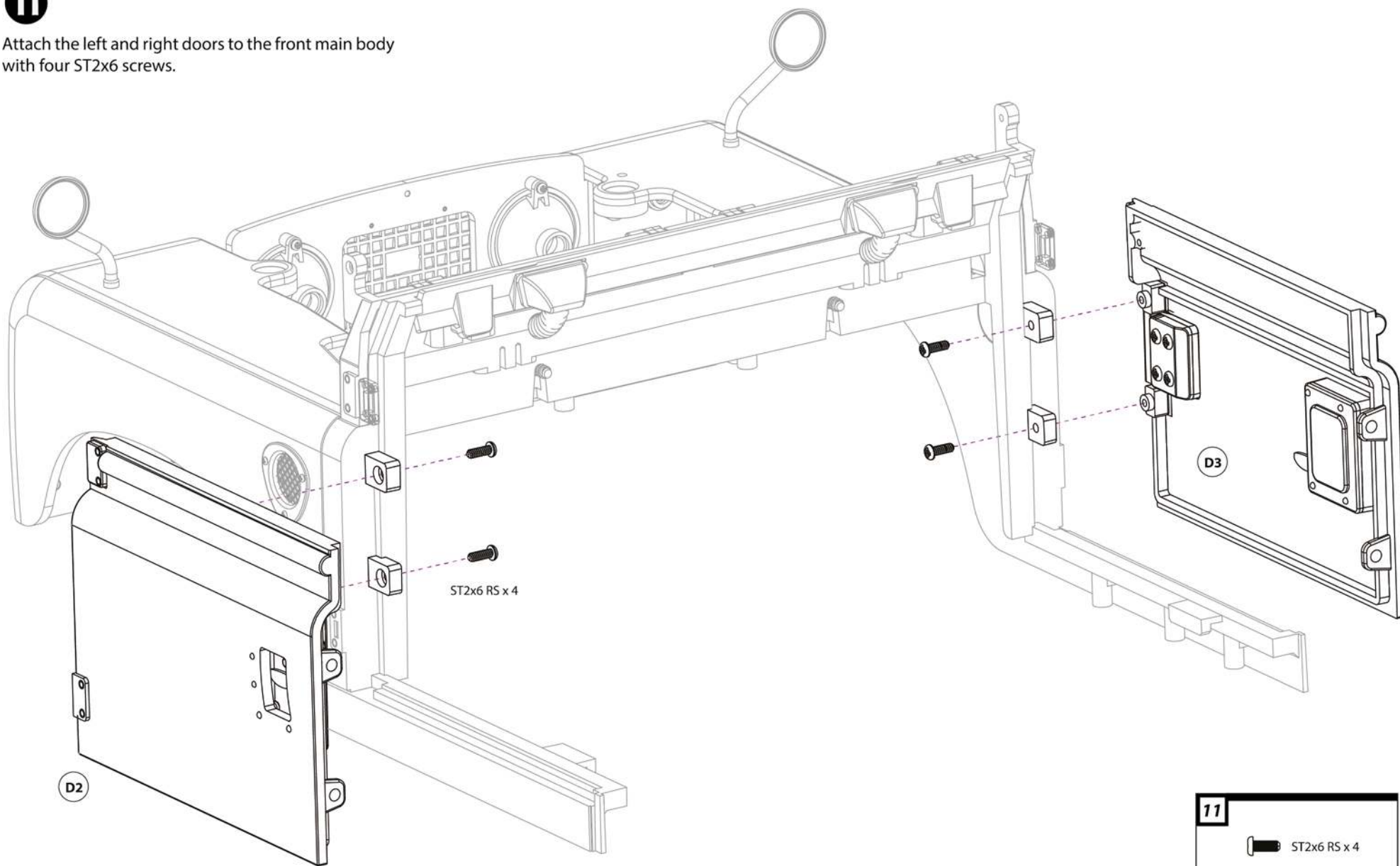

CONVERTIBLE

CONVERTIBLE

12

To build the dash panel, glue the steering column to the rear piece first, then glue the front and rear pieces together.

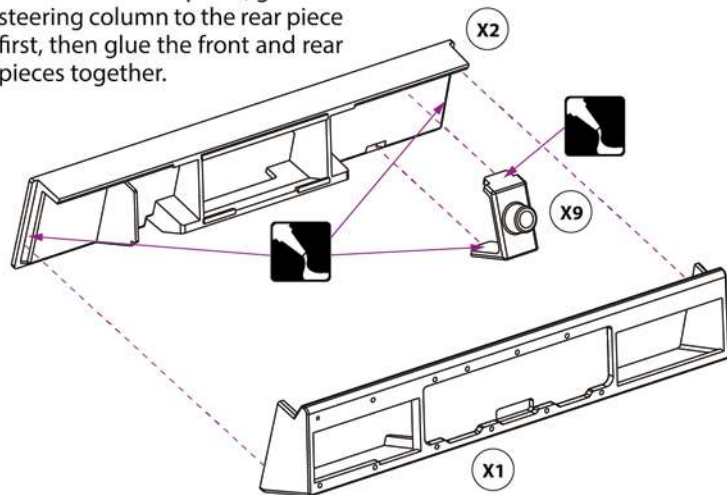

13

Attach the two decals to the instrument plate and place into the dash panel. Glue the four dash controls to the outer instrument panel and attach it to the dash panel with nine ST1x4 screws. Attach the side panel with four ST1x4 screws. Insert steering shaft into steering column and attach the steering wheel.

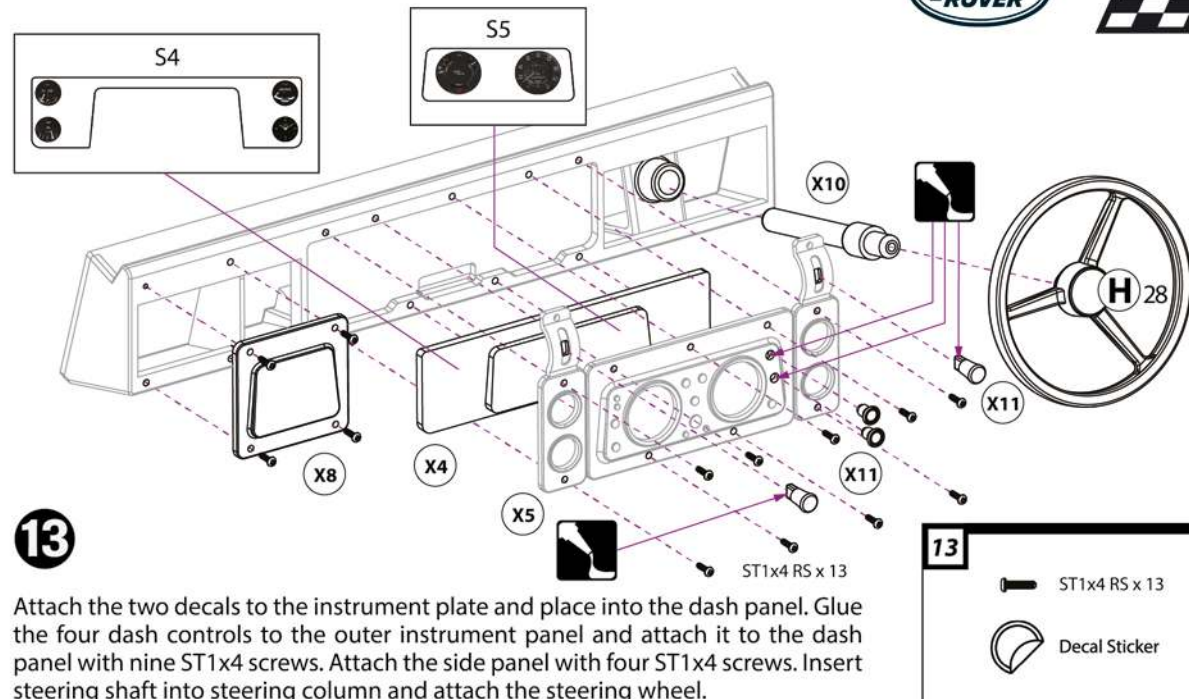

14

ST2.6x6 x 2

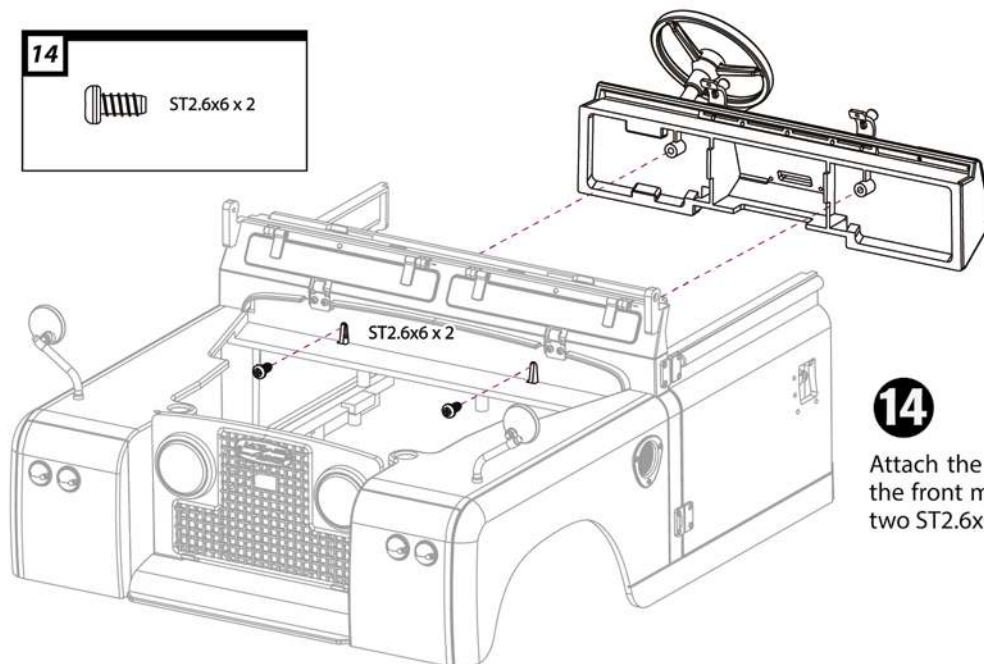

14

Attach the lower dash to the front main body with two ST2.6x6 screws.

15

Once the dash panel is installed, drill two (0.8) holes into the upper dash panel as indicated and attach with two ST1x4 screws.

15

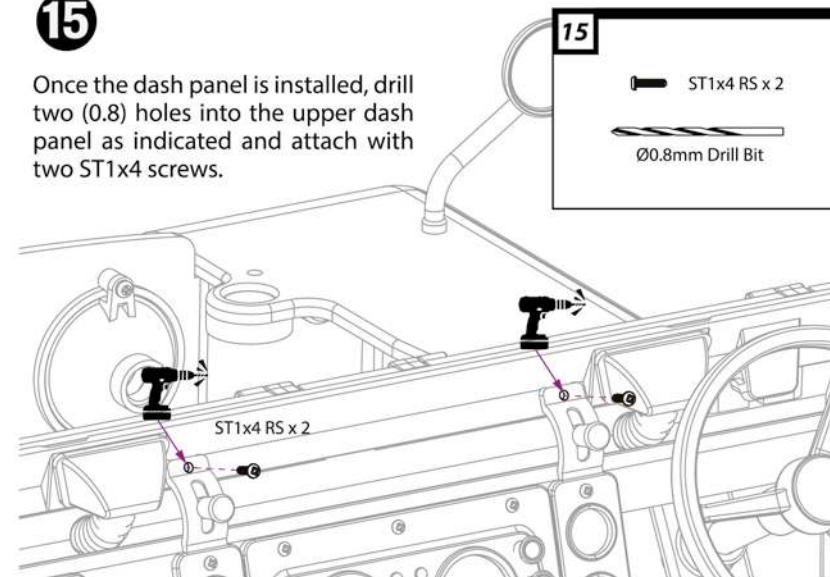
 ST1x4 RS x 2
 Ø0.8mm Drill Bit

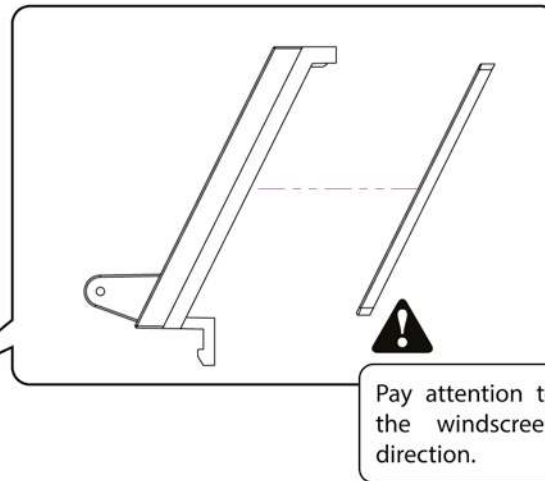
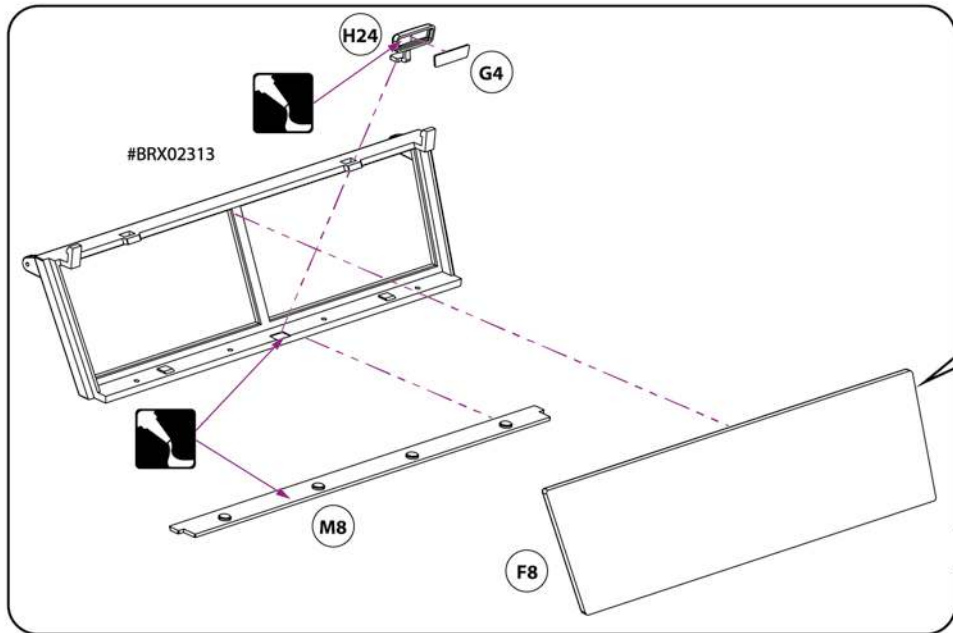

20 Clip the windscreen onto the windscreen frame and glue the interior mirror onto the windscreen frame. Attach the windscreen frame top with glue. Attach the windscreen frame to the vent panel hinge mounts with two ST1.5x5 screws. Insert the hard top screw hole plugs.

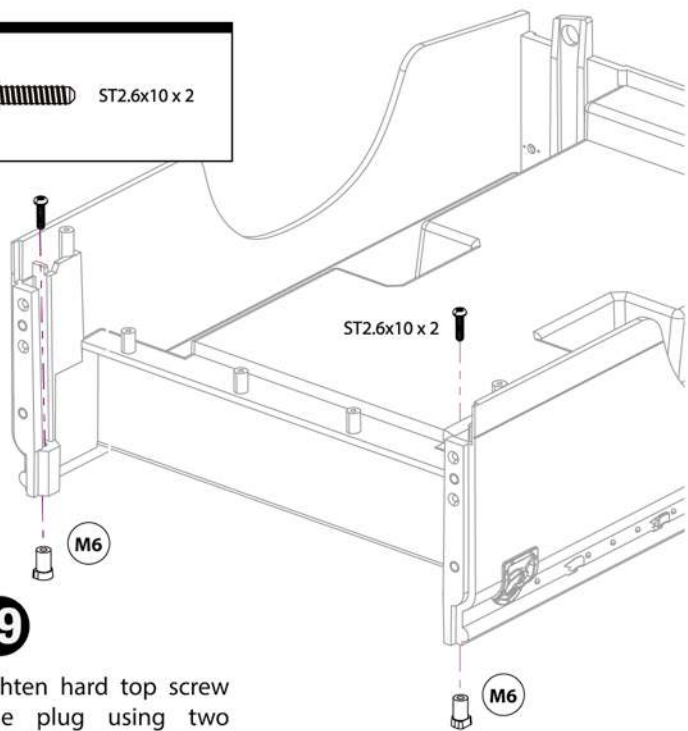
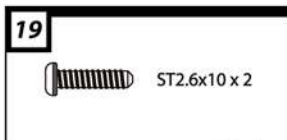

19 Tighten hard top screw hole plug using two ST2.6x10 screws.

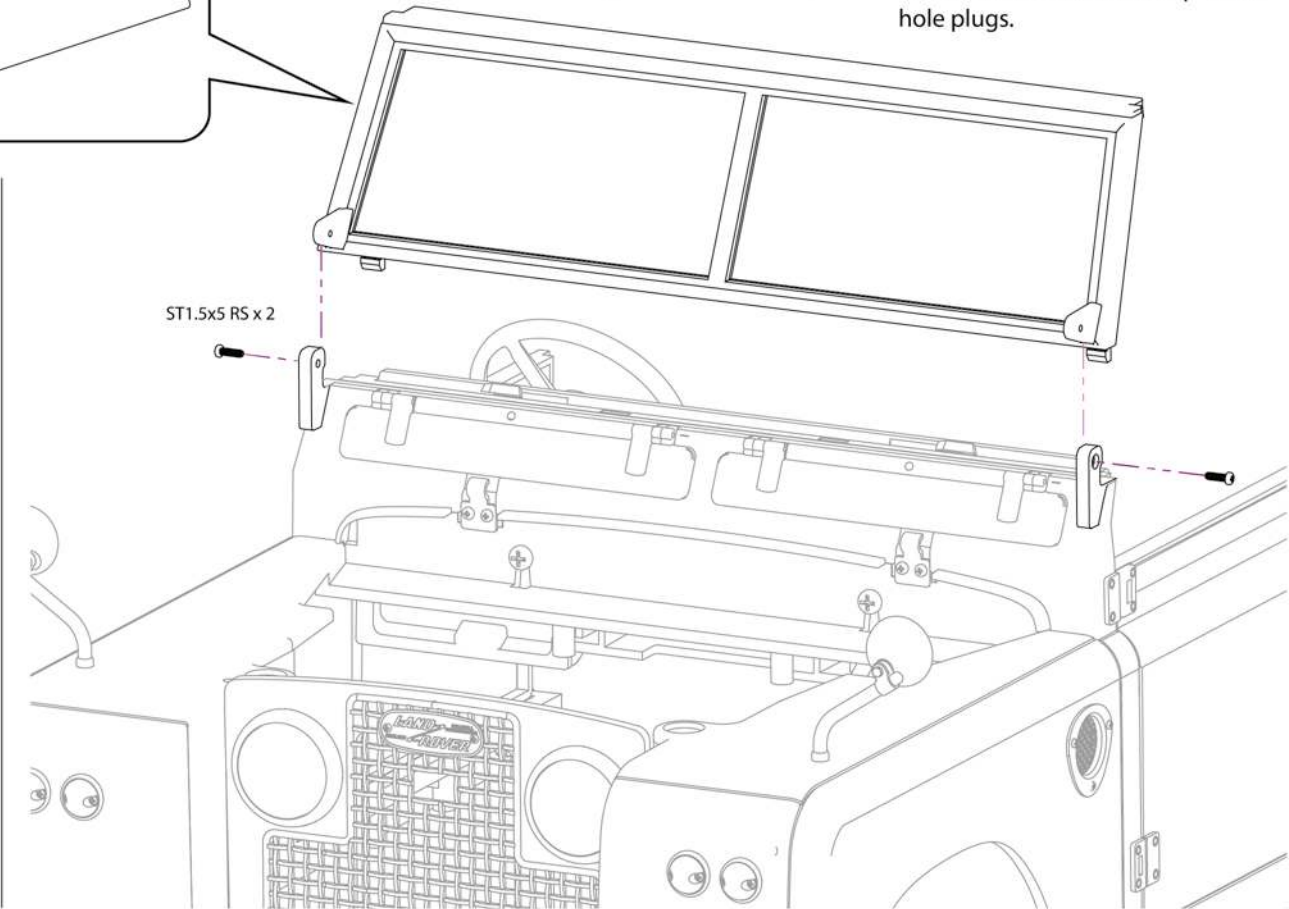

21

ST2x8 RS x 2

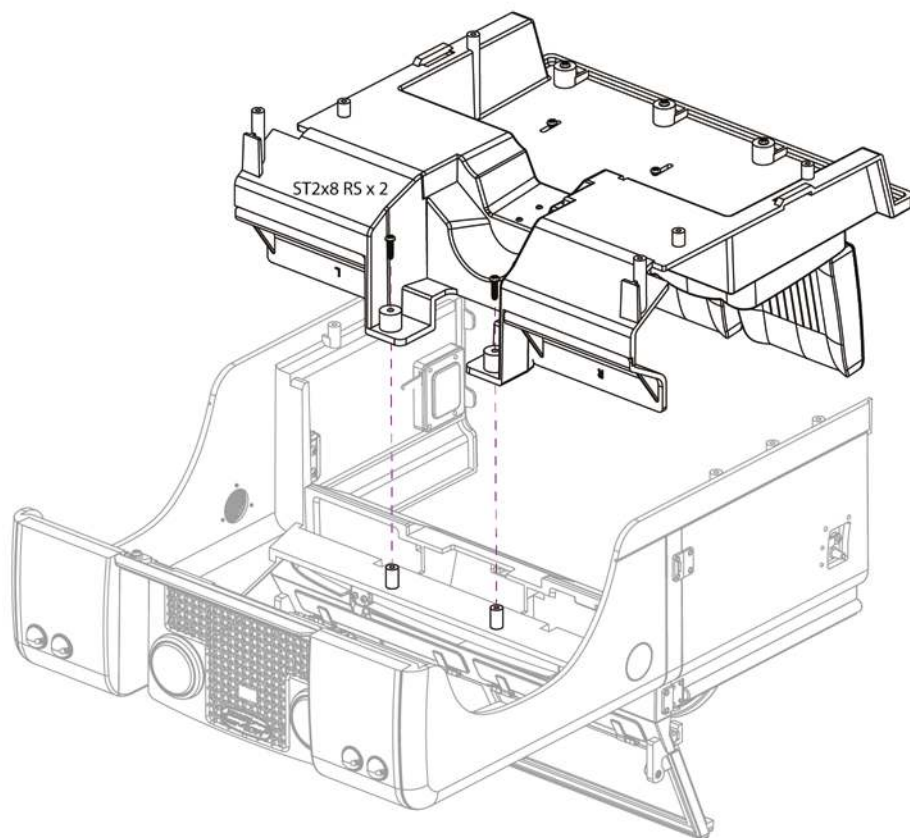

- 21** Line up the front main body with the interior floor and attach using two ST2x8 Screws.

22

ST2x8 RS x4

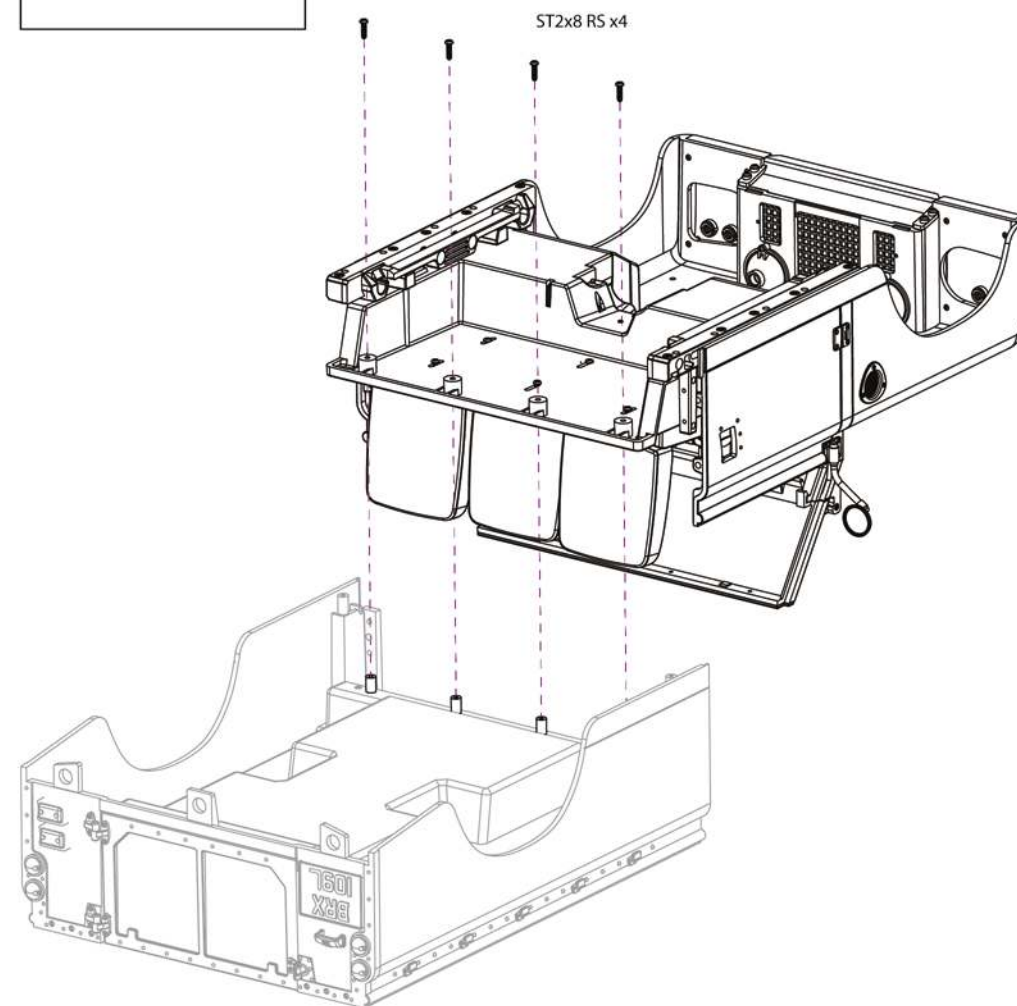

- 22** Line up the rear bed to the front main body with the interior and attach using four ST2x8 screws.

23

 ST2x8 CSS x 10

ST2x8 CSS x 10

23

Install the two aluminum braces to the body using ten STCS2x8 screws to make sure everything is locked into position.

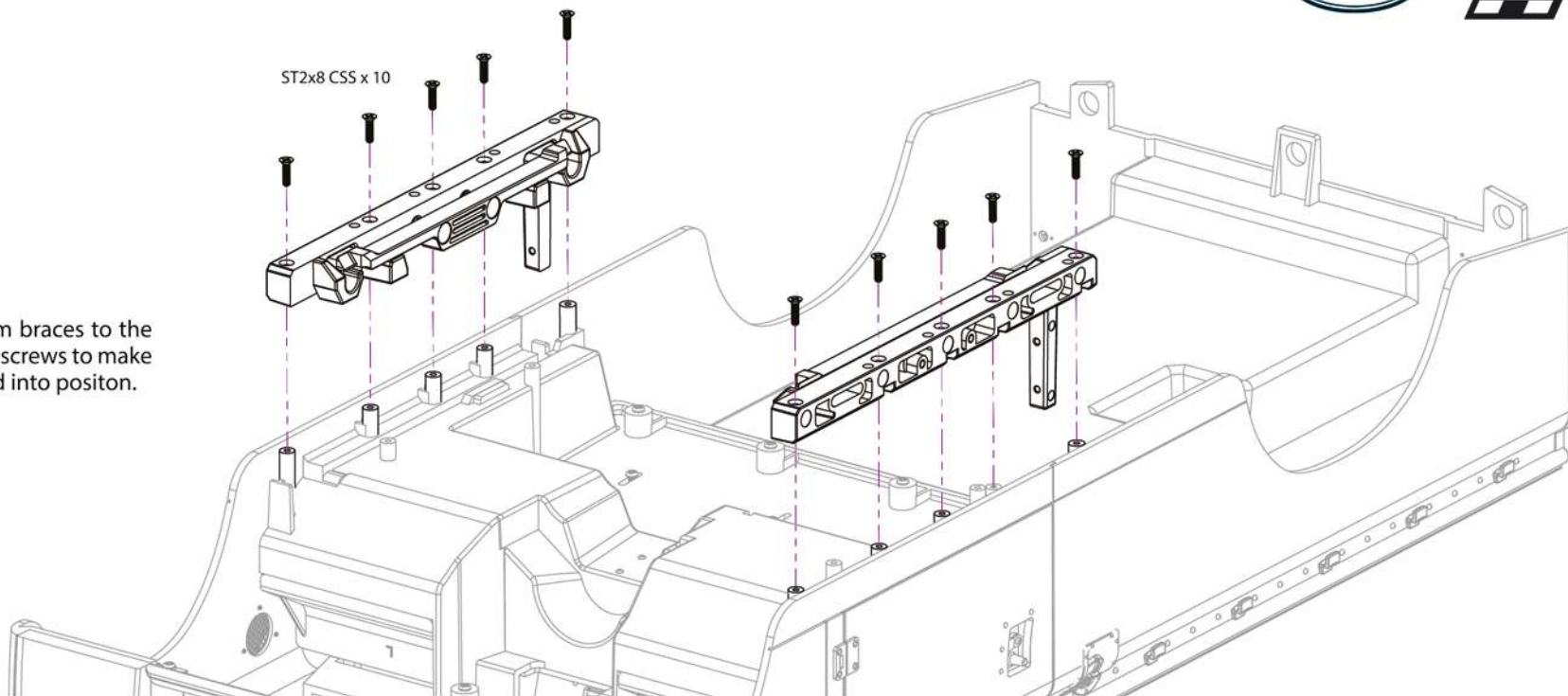

24

 M2x8 CSS x 4

24

Open the doors and fasten two M2x8CS screws on each side into the aluminum brace. Repeat on other side.

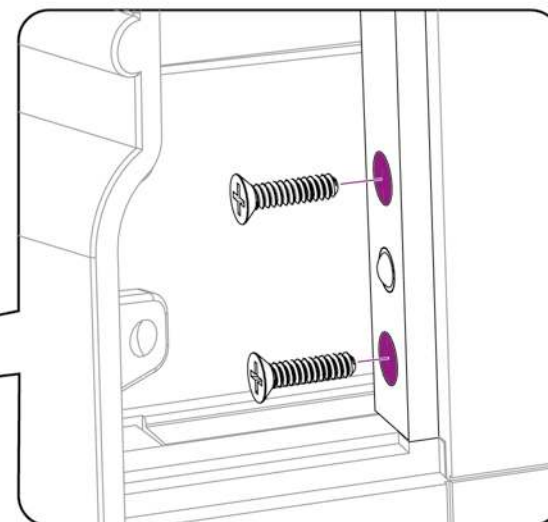
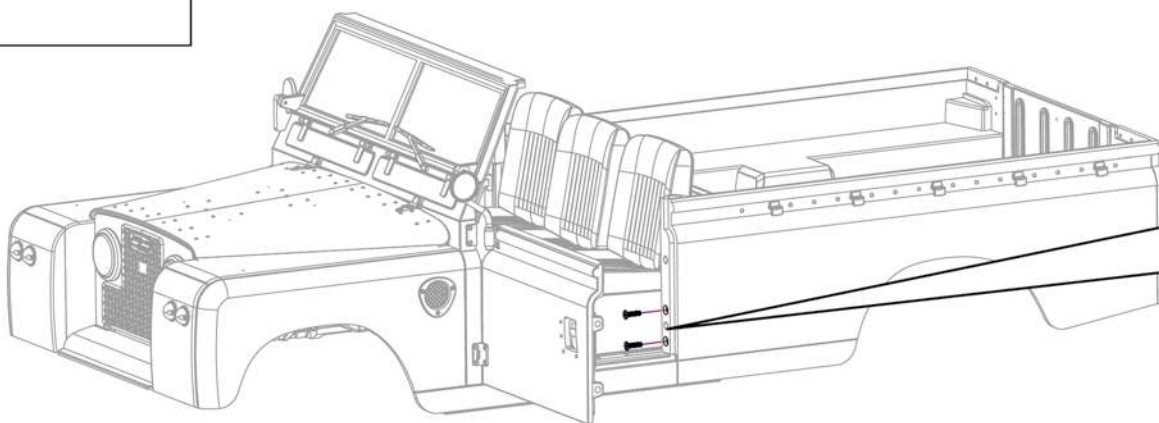

Use the two STCS3x6 screws to adjust the height of the bonnet and how tight they latch to the magnet.



Do not tighten the screws all the way down. The head must not pass the dotted line, otherwise the bonnet can be damaged.

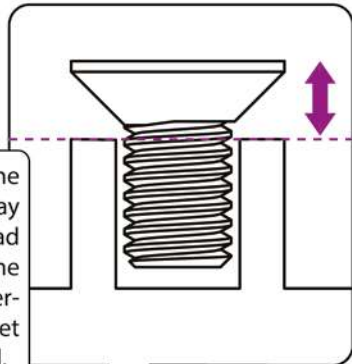

Use the provided 1.0 mm drill bit to pre-drill the six hood hinge holes so the ST1.2x4 screws install smoothly. Keep the screw perfectly straight and tighten slowly.

ST1.2 x 4 RS x 6

L11

L10

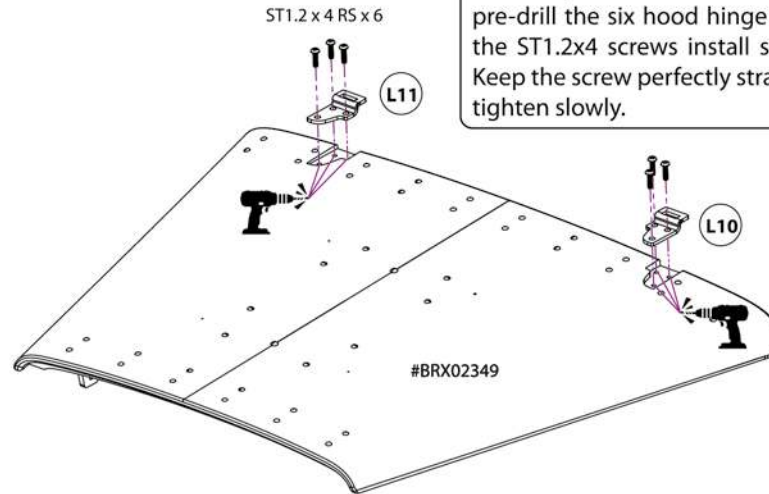

#BRX02349

#BRX02401

ST3 x 6 CSS x 2

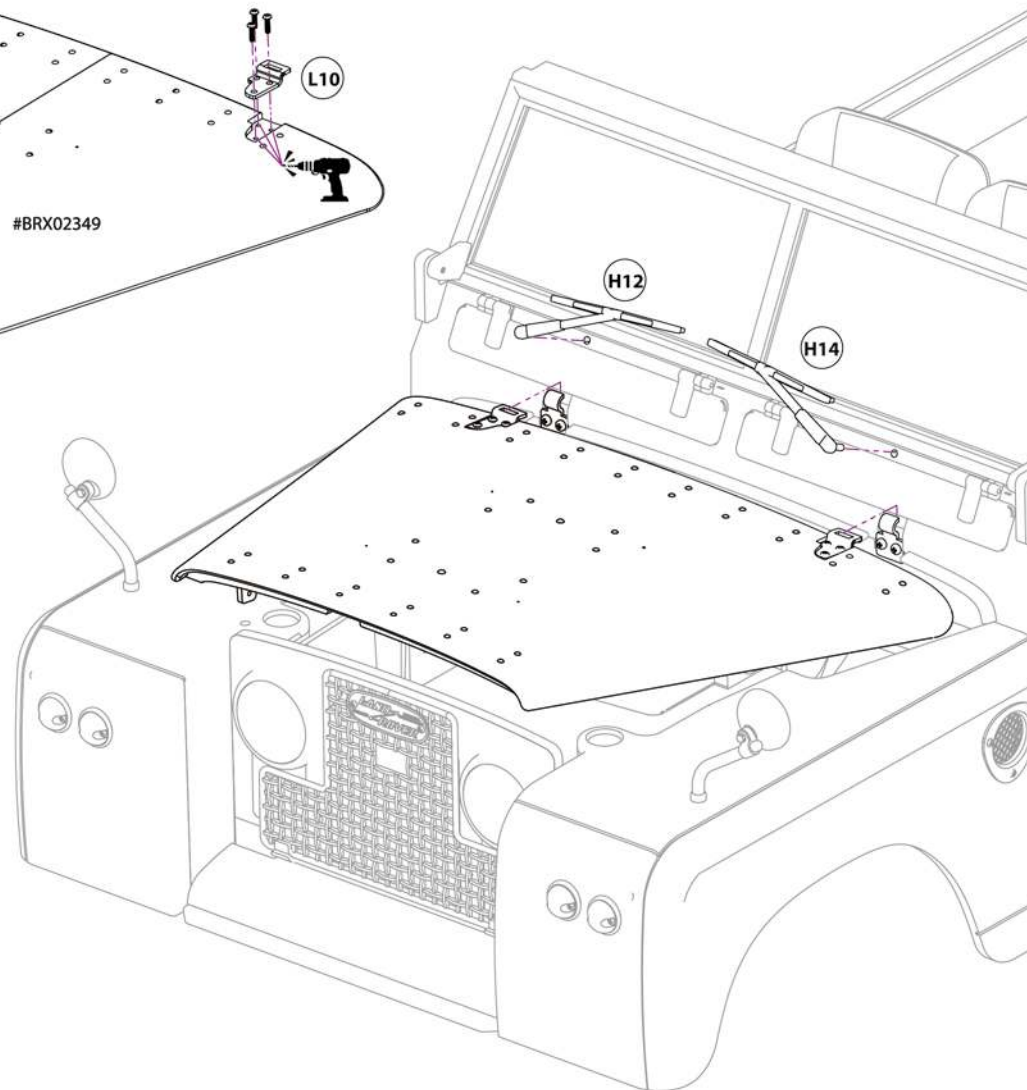
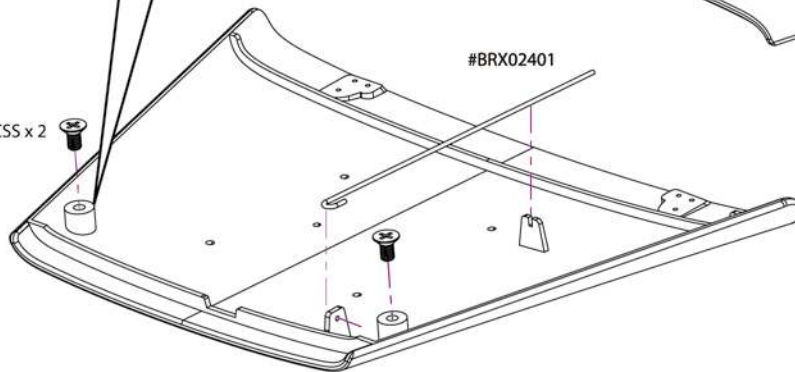

25

 ST1.2x4 RS x6

 ST3x6 CSS x2

 Ø1.0mm Drill Bit

25

Attach the left and right bonnet hinge to the bonnet with six ST1.2x4 screws and two STCS3x6 screws into the bonnet and attach windscreen wipers.



26 Insert the blanking plate to the front chassis crossmember. It should snap into place. Use double-sided tape to attach the license plate to the license plate mount, and the mount to the bumper.

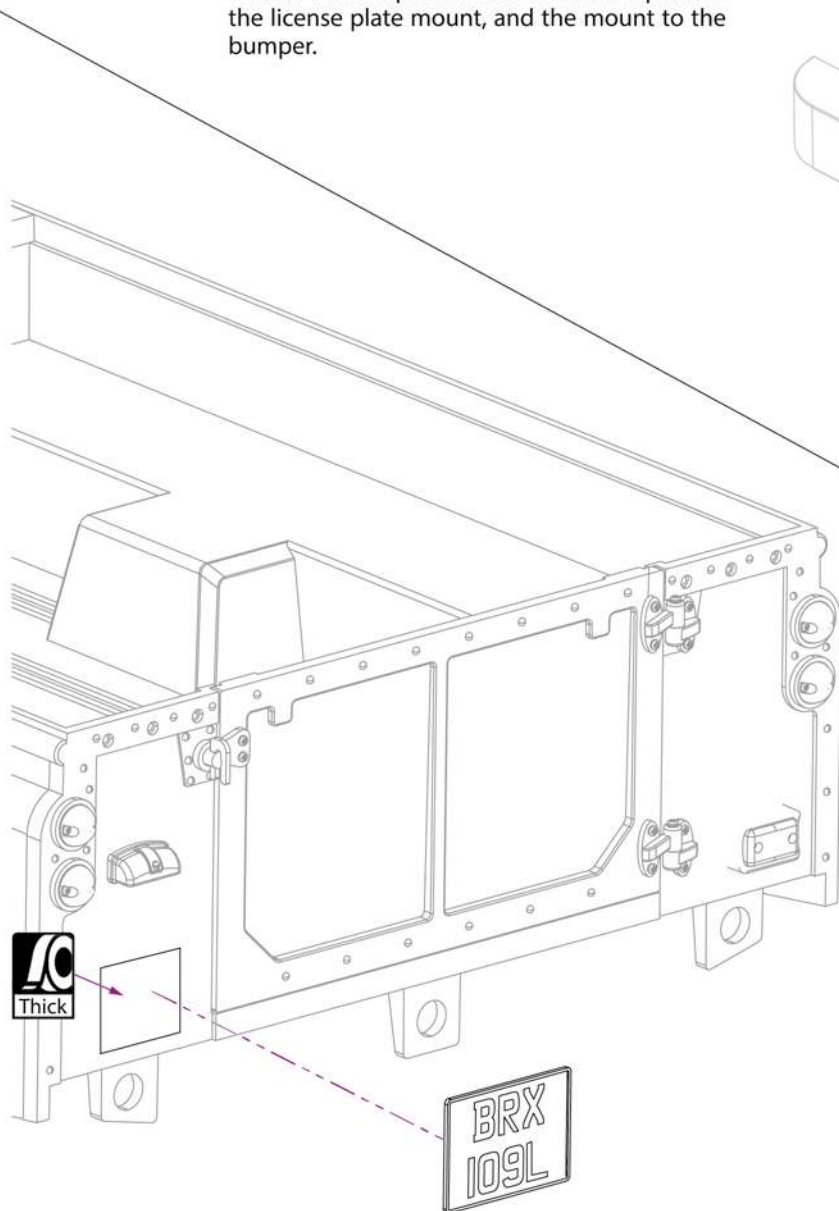
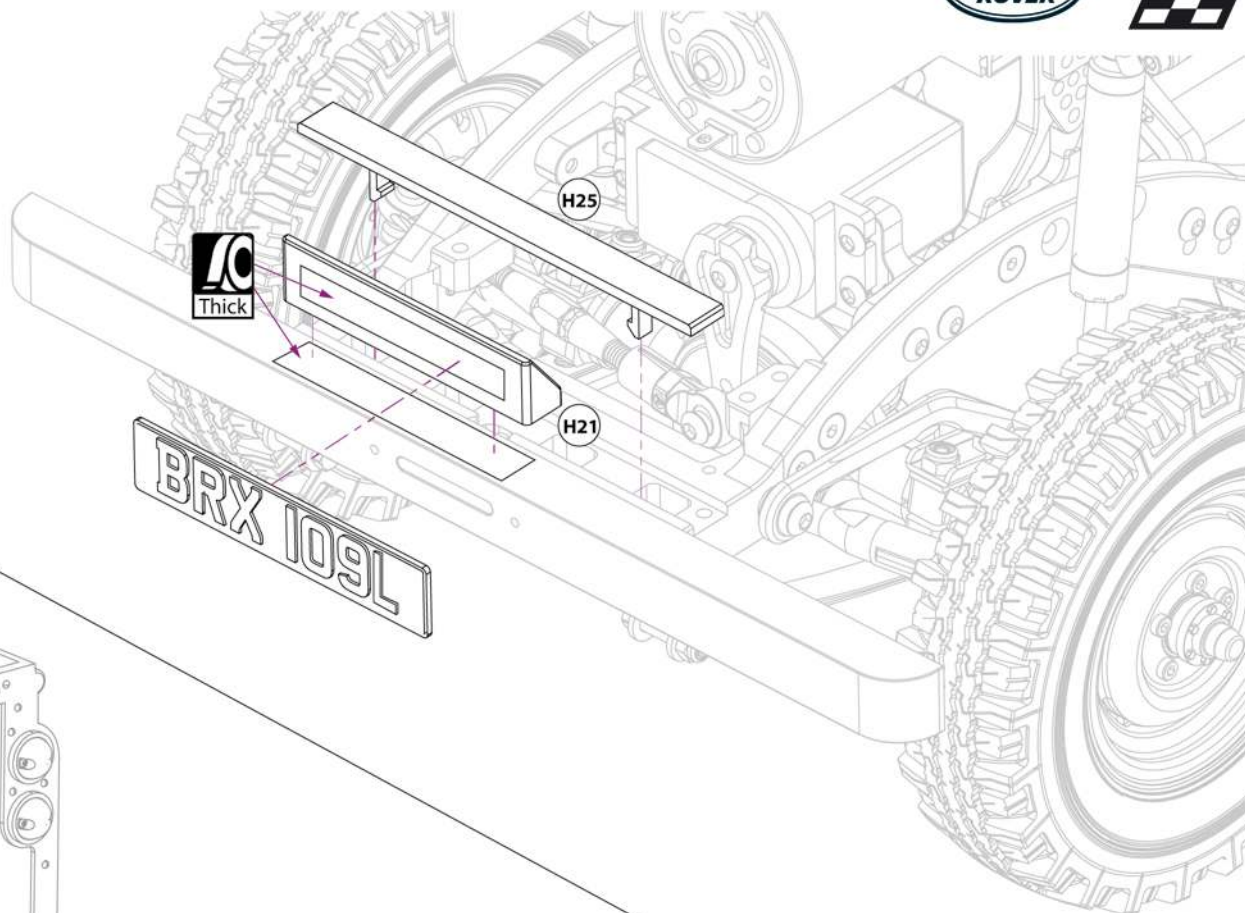

27 Use double-sided tape to attach the rear license plate onto the body below the license plate light.



COMPLETED

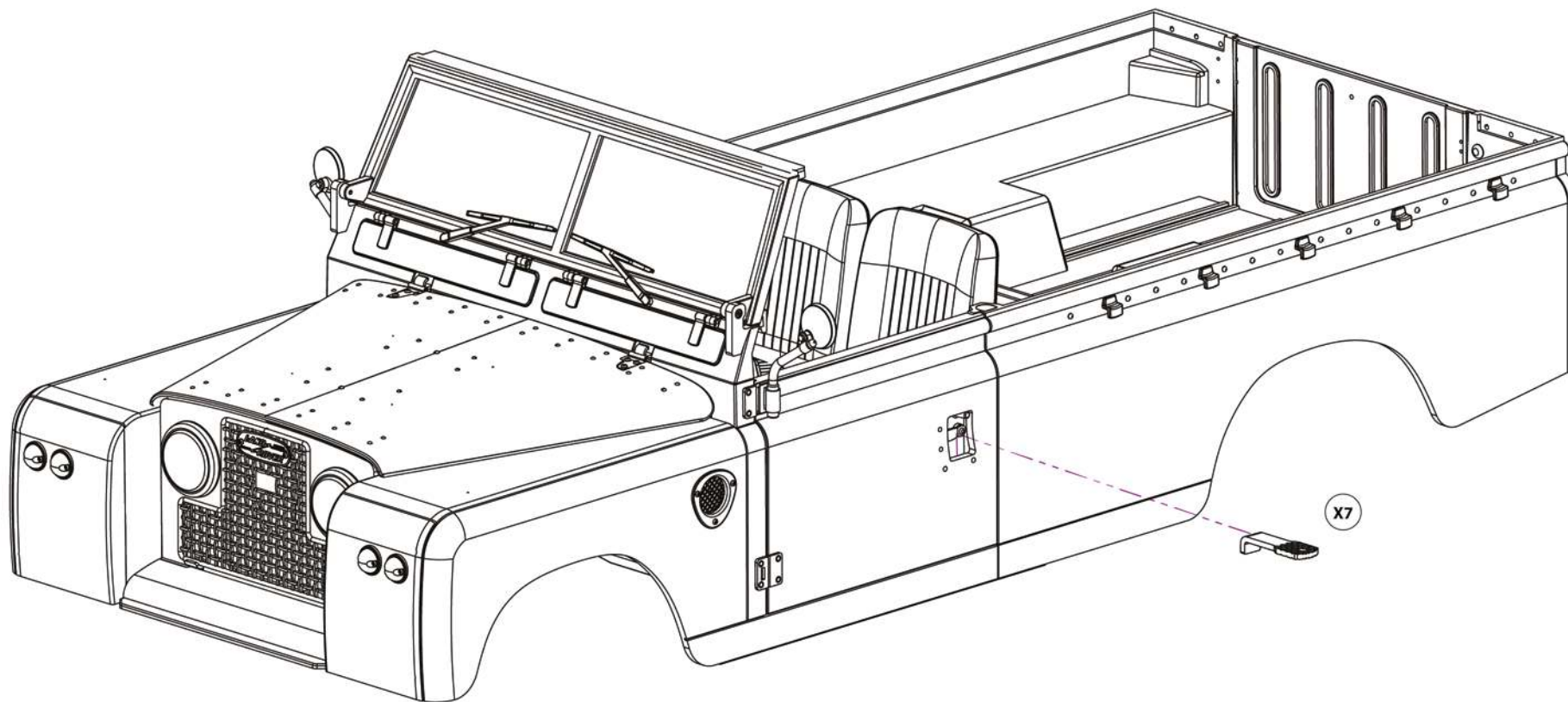

- 28** Use the door key and hook it onto the door to pull the door open.



 @BOOM_RACING

 BOOMRACINGRC

 SALES@BOOMRACING.COM

www.enjoybeingabadass.com

BOOMRACING  [®]
Your Radio Control Car Specialist



Land Rover and the Land Rover Logo are trademarks owned and licensed by Jaguar Land Rover Limited.